

LASER MARKING SYSTEMS

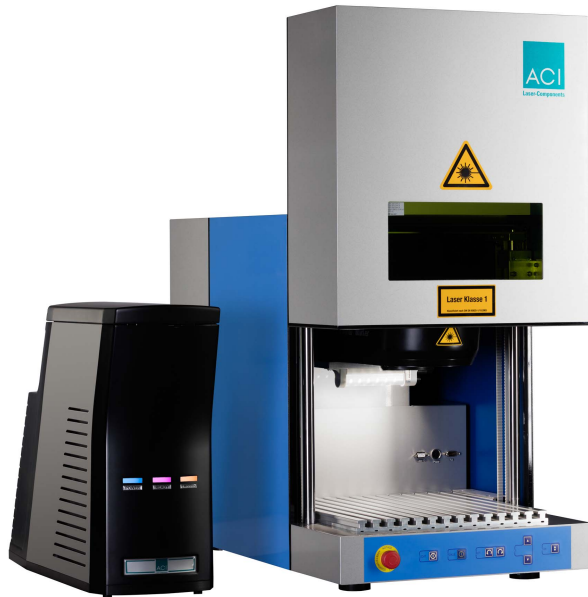

Operating Instructions

Workstation *CLASSIC* Fibre

Workstation *CLASSIC* Fibre XL

Mark your territory...

This product conforms to the requirements of the Directive 2006/42/EC on machinery.
The CE symbol is located on the type plate.

Manufacturer: ACI Laser GmbH
Steinbrüchenstraße 14
D-99428 Grammetal OT Nohra
Germany

Phone: +49 3643 4152-0
Fax: +49 3643 4152-77
info@ACI-Laser.de
www.ACI-Laser.de

We are constantly working on further developments.

Therefore, please understand that we must reserve the right to change the scope of the delivery in respect of the form, equipment and technology at any time.

Reprinting, copying or translating this document in whole or in part is forbidden without the express written permission of ACI Laser GmbH!

All rights under the copyright laws are expressly reserved by ACI Laser GmbH.

The manufacturer shall only be responsible for the safety characteristics of this device within the scope of the legally applicable regulations if it is operated by the user in accordance with the operating instructions and repaired by ACI Laser GmbH itself or someone appointed by and acting under the instructions of ACI Laser GmbH.

Last update: 08/2019-03

© ACI Laser GmbH

Table of Contents

1	Introduction	7
2	Important Information	7
2.1	Intended Use	8
2.2	Improper Use	8
2.3	Notices in the Document	9
2.4	Warranty	10
2.5	Technical Customer Service	11
3	Safety	12
3.1	Basic Safety Instructions	12
	Laser safety	12
	Emissions	13
	General	13
	Start up	13
	Operation	14
	Maintenance/care	14
3.2	Labels at the Device	15
	Warning signs	15
	Type plate	16
4	Description	17
4.1	Intended Purpose	17
4.2	Views of the Device	18
	Front side	18
	Rear side	19
4.3	Technical Specifications	20
	Laser marking system	20

Table of Contents

	Usable mounting area of the T-slot plate	20
	Adjusting the height with the focus finder function	20
	Positioning and repetition accuracy	20
	Safety door	20
	Max. component heights and marking fields	20
	Maximum working areas	20
	Laser protection screen	21
	Lighting	21
	Extraction	21
	Operation	21
	Laser protection class	21
	Interfaces	21
	Electrical data	21
	Operating conditions	22
	Weight without laser	22
	Options	22
4.4	Scope of Delivery	22
5	Installation	23
5.1	Unpacking	23
5.2	Setting Up	24
5.3	Assembly	25
5.3.1	Connections	25
	Rear side	25
	Workroom	25
5.3.2	Laser Marking Device Assembly	26
5.3.3	Extraction Assembly	26
5.3.4	Power Connection	26
5.3.5	Connection of Supply Cable and Fiber Laser Cable	27
5.3.6	Connection with PC	28

5.4	Checking the Installation	28
6	Operation	29
6.1	Operating and Display Elements	29
	Control panel	29
	Emergency stop button	30
6.2	Start	31
6.3	Handling	31
6.4	Fault Finding	32
7	Maintenance, Repair, Care	33
	Cleaning	33
8	Scrap Disposal	34
9	Appendix	35
9.1	Wiring Diagram	35
9.2	Drawing of the T-Slot Plate	37
9.3	Assembly Dimensions	38
9.4	Drawing of the Axis Stroke	40
9.5	Illustration of the Rotary Module	41
9.6	Illustration of the Working Areas	42
9.7	EC Conformity Declaration	43
10	Index	45

1 Introduction

Dear customer,

Thank you for the confidence which you have shown in us by purchasing our quality product. We would like to wish you every success with the use of the devices.

Make yourself familiar with these operating instructions before starting use. It tells you how to use the new devices correctly and safely, and takes you step by step through the actions which have to be performed before using it for the first time.

You will find more detailed information on the enclosed CD-ROM.

2 Important Information

Our products are developed and manufactured under strict quality monitoring to give a long and fault-free service life.

This guarantees:

- highest quality and a long life,
- easy and safe operation,
- functional design,
- optimization for the intended purpose.

The **Workstation CLASSIC Fibre** is state-of-the-art. The Declaration of Conformity confirms that the manufacturer has complied with the relevant directives. The CE mark is located on the type plate.

Please read these operating instructions carefully from the beginning in order to avoid errors and risks.

Reference is made to residual hazards at the relevant places in the operating instructions. Please also take note of the warning notice stickers on the device.

2.1 Intended Use

- The **Workstation CLASSIC Fibre** is intended exclusively for use with the following laser marking devices and the associated **Magic Mark** software:
Economy/Business Fibre **DFL Ventus Marker**
- Usage for the intended purpose includes observance of these operating instructions, the operating instructions of the laser marking device, the instructions in the software manual and the warning stickers on the device.

2.2 Improper Use

All other uses other than use for the intended purpose shall be deemed to be improper use!

The workstation must not be used by:

- persons who have not read or understood these operating instructions,
- persons who have not been instructed in the proper operation,
- persons who are under the influence of alcohol and or drugs, or
- persons whose alertness is impaired by medicines or other influences.

The workstation must not be used:

- if protective/safety devices are bridged, defective or if they cannot reliably fulfil their function,
- if there is a suspicion that direct or leakage radiation can emanate.



The supplier/manufacturer shall not be liable for personal injury or material damage resulting from improper use of the workstation itself or the safety devices.

2.3 Notices in the Document

Take note of the warning notices, take the specified actions and observe the prohibitions. A warning notice warns of a possible hazard and contains recommendations for preventing the hazard occurring. Key words indicate the type of hazard, symbols emphasise this visually.

Follow the stated measures for preventing hazards to the operator or tangible material assets.

The following classification of dangers are used in these safety instructions:

 DANGER
RISK OF DEATH OR SERIOUS INJURIES! Indication of an imminent danger, which will result in death or serious injuries if the appropriate precautionary measures are not taken.
 WARNING
DANGER OF INJURIES AND/OR RISK OF PROPERTY DAMAGE. Indication of an immediately impending hazard which can cause serious injuries or property damage if the appropriate precautionary measures are not taken.
 CAUTION
RISK OF PROPERTY DAMAGE. Indication of a possible hazard which may cause damages of the equipment if the appropriate precautionary measures are not taken.

Additional information on working with the device and protection of the environmental are emphasised as follows:

NOTICE

Useful additional information and tips!

ENVIRONMENT

**Protect the environment!
Instructions for observing environmental protection regulations!**

2.4 Warranty

The manufacturer guarantees that the product does not have any manufacturing or material defects.

The warranty period shall be 12 months from the dispatch date in as far as no other contractual ruling has been made.

The scope of warranty is limited to the repair or replacement of the product supplied by the manufacturer.

The manufacturer is responsible for returning repairs under warranty to the customer, the customer is responsible for returning the device to the manufacturer.

The manufacturer does not accept any liability,

- if the product has been damaged by incorrect handling or operation, or as a result of improper use,
- if seals on the device have been broken,
- for damage caused by use under unauthorized environmental conditions,
- for consequential damage.

2.5 Technical Customer Service

ACI Laser GmbH
Steinbrüchenstraße 14
D-99428 Grammetal OT Nohra
Germany

Phone: +49 3643 4152-0
Fax: +49 3643 4152-77
service@ACI-Laser.de
www.ACI-Laser.de

NOTICE

The workstation may only be maintained and repaired by the manufacturer. Any manipulations on the device or breaking the warranty seal will void any claims under warranty.

3 Safety

3.1 Basic Safety Instructions



The following safety instructions have fundamental importance for the use of the workstation, and for its care and maintenance.

They must always be followed and are only stated centrally here.

Laser safety

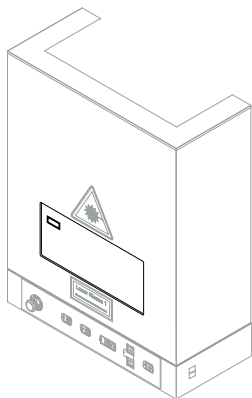

If used properly, the workstation with an integrated laser marking device can be operated in laser protection class 1.

The laser protection screen in the viewing window is matched to the characteristics of the laser marking device. The specification corresponds at least to the required protection level and can be taken from the adhesive label on the window.

- Only use the workstation and laser marking device in the combination supplied by the manufacturer!
- If the protection screen is damaged, the device must not be operated.

Emissions

- Chemical and physical reactions during the laser marking can cause
 - gases,
 - vapours,
 - aerosols,
 - dusts,
 - mists or
 - other reaction products

to be given off from the material surface.

These may be toxic, depending upon the material being processed. The operating company must therefore provide effective extraction. Information about this can be found, for example, in the VDI Guideline 2262 1 to 3 "Air Quality in the Work Place".

General

- Read the Operating Instructions, and keep them at hand at all times.
- Follow the Operating Instructions for the laser marking device.
- Follow the Operating Instructions for the air conditioner and the instructions for any other devices made by other manufacturers (for example extraction units).
- Do not mark any easily flammable or combustible materials.

Start up

- Each time before starting up, ensure that all safety devices are mounted and working perfectly.
 - Covers
 - Door mechanism
 - Emergency stop button
- Never use the device system immediately after large temperature changes. Condensation water may damage the device.

Safety

Operation

- The workstation may only be operated by trained personnel. It is advisable to log both the initial training as well as the regular refresher courses.
- The device may only be operated when connected to an alternating voltage supply corresponding to the specifications on the type plate.
- The effectiveness of the protective conductor must be regularly checked and confirmed by an authorized skilled worker.
- If a defect occurs in the workstation, it must be disconnected from the power supply system and secured against being switched on again.

Maintenance/care

- Maintenance and repair work on the workstation may only be performed by the manufacturer.
- Disconnect the device from the power supply before starting cleaning and care tasks.
- Do not touch the electrical/electronic components.

3.2 Labels at the Device

Warning signs

The warning signs on the device indicate possible residual hazards.

- On the workroom door: Warning about laser radiation!

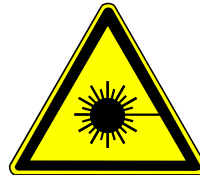
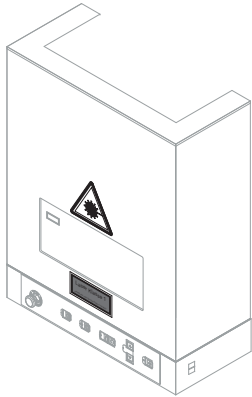





Type plate

The type plate on the rear of the workstation contains information about:

- Serial number,
- Manufacturer,
- Date of manufacture,
- Operating voltage/frequency range,
- Power consumption,
- Fuse,
- Laser protection screen on the device.

ACI Laser GmbH Steinbrüchenstraße 14 99428 Grammetal OT Nohra Germany phone: + 49(0)3643 4152-0 fax: + 49(0)3643 4152-77 www.ACI-Laser.de info@ACI-Laser.de	Model / Modell: WorkstationCLASSIC Serial Number / Seriennummer: CL-20200101 Manufacturer / Hersteller: ACI Laser GmbH Date of Manufacturing / Herstelldatum: 01/2020 Line Voltage / Betriebsspannung: 110-230VAC / 50-60Hz Max. rated power / Max. Leistungsaufnahme: 1000W Fuse / Sicherung: 230V: 5AT 110V: 10AT Laser protection window / Laserschutzscheibe: 1064nm DL5 IR L6
--	--

Vor Öffnen des Gehäuses Netzstecker ziehen!
Disconnect power before opening cover!
Avant d'enlever le capot débrancher l'appareil!

4 Description**4.1 Intended Purpose**

The manual workplace solution **Workstation CLASSIC Fibre** is characterized by its large workroom. You can mount workpieces with an area of up to 340 mm x 360 mm on its T-slot plate.

Depending on the laser system and objective used, a marking field of maximum 180 mm x 180 mm is available.

The integrated electrically driven Z axis allows marking on workpieces with differing heights. The stroke length of the Z axis is 150 mm.

A focus finder (consisting of two pilot lasers) assist the operator in setting up the proper working distance within a few seconds.

The electrically driven safety door enables workpieces to be changed easily.

Description

4.2 Views of the Device

Front side

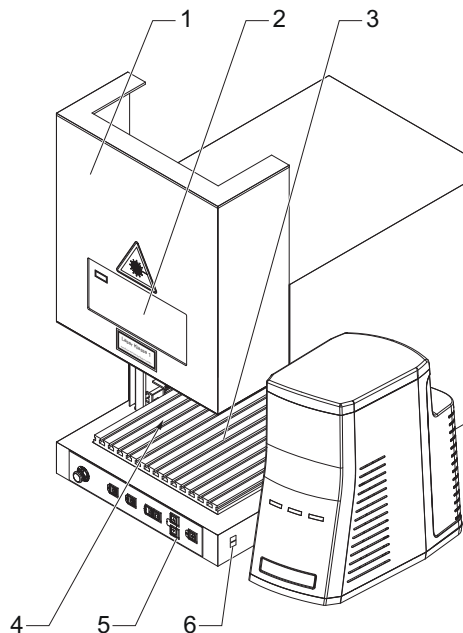

- (1) Safety door
- (2) Viewing window
- (3) T-slot plate
- (4) Workroom
- (5) Control panel
- (6) Power switch

There are also additional connections in the workroom.

Rear side

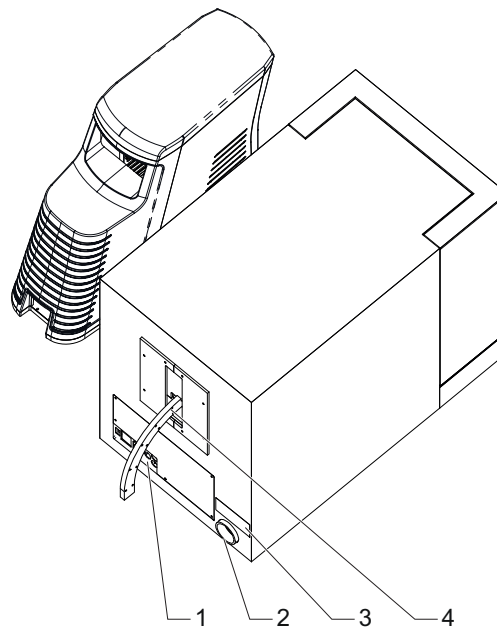

- (1) Connections rear side
- (2) Extraction connector
- (3) Type plate
- (4) Fiber laser cable

Description

4.3 Technical Specifications

Laser marking system	Economy/Business Fibre:	DFL Ventus Marker
Usable mounting area of the T-slot plate	Width x Depth:	340 mm x 360 mm
Adjusting the height with the focus finder function	Motorized Z axis: Stroke length: Operation: Focus finder:	Linear axis with stepper motor drive 150 mm Integrated membrane keyboard/operating software 2 pilot laser diodes
Positioning and repetition accuracy	Z axis:	< ± 0.15 mm
Safety door	Automatically movable	

Max. component heights and marking fields

	Objective	Max. component height	Marking field
CLASSIC Fibre	F-Theta 163	150 mm	110 mm x 110 mm
CLASSIC Fibre XL	F-Theta 163	270 mm	110 mm x 110 mm
	F-Theta 254	143 mm	180 mm x 180 mm

Maximum working areas

The working areas correspond to the physical marking fields of the laser systems.

Laser protection screen

Width x Height: 276 mm x 200 mm
 Specification: Depends on the type of laser device used

Yb:fibre laser	1040 - 1100 nm	D AB6 IR AB6 (DIN EN 12254)
	>1100 - 1185 nm	D AB6 IR AB6 (DIN EN 12254)
	>1185 - 1215 nm	D AB5 IR AB5 (DIN EN 12254)

The listed laser protection screen specifications are the minimum requirements for the protective windows. Depending on the application, laser protection screens with higher levels of protection may be installed. The specifications of the laser protection screen can be found on the adhesive label on the window.

Lighting

Integrated workroom lighting

Extraction

Connection for external extraction unit is ready

Operation

Integrated membrane keyboard/operating software

Laser protection class

1

Interfaces

Interface: USB 2.0
 Power connection: Connector for non-heating apparatus, filtered

Electrical data

Connection values: 230 V/ 5 A/50 Hz
 110 V/10 A/60 Hz
 Power consumption (typical): Max. 400 W plus
 laser marking device (max. 600 W)
 Fuse: 230 V: 5 A
 110 V: 10 A

Description

Operating conditions	Working temperature:	15°C - 35°C
	Air humidity (rel.):	30% - 85%, not condensing

Weight without laser 45 kg

- Options**
- Workpiece holders
 - Laser extraction unit
 - Rotary module
 - Foot switch

4.4 Scope of Delivery

- Workstation,
- connecting cable for USB 2.0,
- laser interface cable,
- power cable,
- control cable interlock,
- extraction hose, internal,
- operating instructions.

Optional:

- Extraction unit with control cable and extraction hose,
- rotary module,
- foot switch.

NOTICE

Check that the delivery is complete and undamaged. Please contact our service department if you have any queries.

5 Installation

5.1 Unpacking

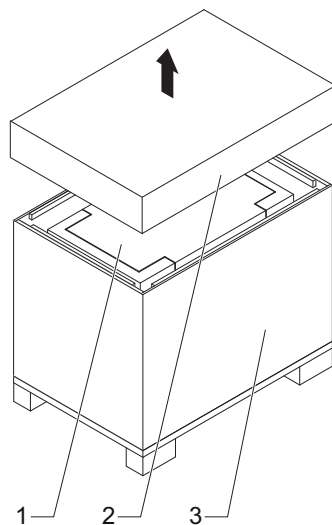

- (1) Workstation
- (2) Lid
- (3) Carton

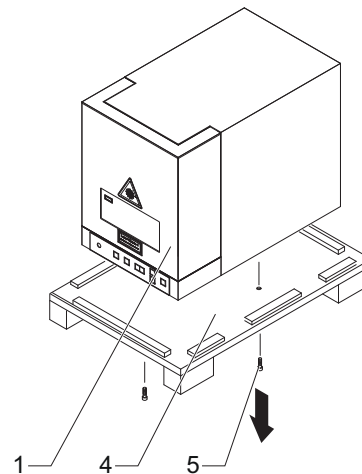

- (4) Pallet
- (5) Fixing screws

The workstation is supplied packed in a carton on a pallet. It is screwed to the pallet, and secured by tensioning straps.

The accessories are located in the workroom.

1. Remove the tensioning straps.
2. Remove the lid (2).
3. Remove the carton (3).
4. Lift the pallet (4) bearing the workstation (1) with a suitable device (such as a lifting truck), and remove the fixing screws (5).

NOTICE

The **Workstation CLASSIC Fibre** weighs 45 kg.

5. Place the device on a suitable flat surface.
6. Remove the accessories from the workroom, and put them in a safe place.
7. Check the scope of delivery.

5.2 Setting Up

1. Place the workstation on a stable, flat table.
2. Use a spirit level to check that the workstation is horizontal.
It can be adjusted by screwing the four feet in or out as necessary.

5.3 Assembly

5.3.1 Connections

Rear side

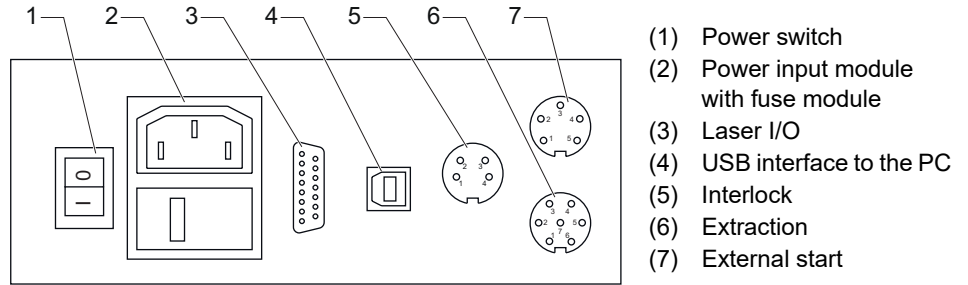

Workroom

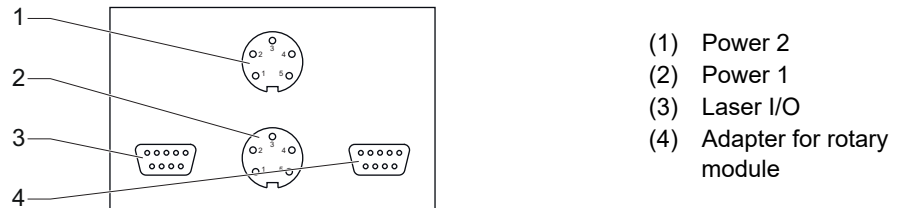

5.3.2 Laser Marking Device Assembly

1. Fasten the laser marking unit to the mounting panel of the workstation, following the laser marking unit's operating instructions.
2. Connect the three connecting cables
 - laser interface cable,
 - power cable,
 - USB cable,to the laser marking device.

5.3.3 Extraction Assembly

1. Connect the control cable between the extraction unit and the workstation.
2. Connect the extraction hose.
3. Connect the power cable to an earthed socket.

NOTICE
For all other work, follow the operating instructions for the extraction unit.

5.3.4 Power Connection

1. Ensure that the device power switch is switched off.
2. Connect the supplied power cable to the power input module of the workstation.
3. Connect the power cable to an earthed socket.

5.3.5 Connection of Supply Cable and Fiber Laser Cable

The supply cable and the BDO fiber laser cable between the laser head and supply unit must be connected.

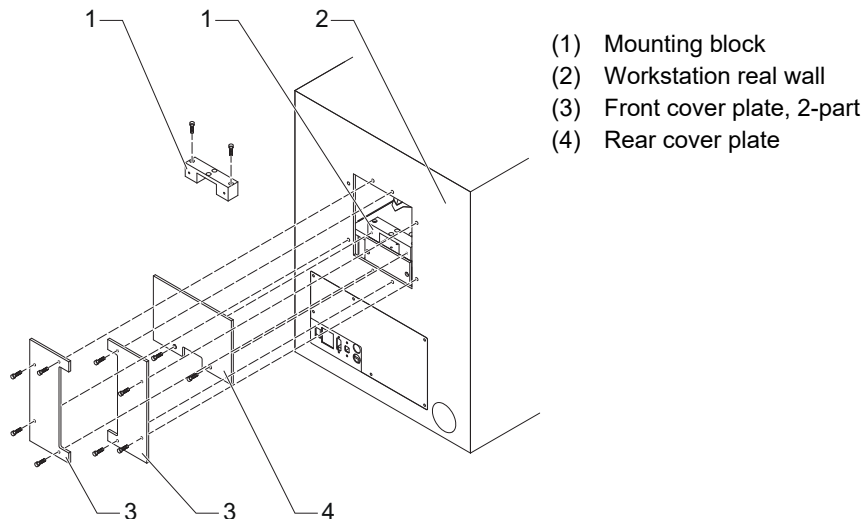

1. Unscrew the 2-part front cover plate, the rear cover plate and the mounting block.
2. Plug in the supply cable and the BDO fiber laser cable.
Ensure that the fiber laser cable is not kinked - observe the operating instructions of the laser marking device.

3. Screw the mounting block, the rear cover plate and the 2-part front cover plate in finger tight.
Ensure that the cables are not pinched in the process.

5.3.6 Connection with PC

Connect the USB interface on the workstation to the PC.

5.4 Checking the Installation

CAUTION

RISK OF PROPERTY DAMAGE.

Perform the following tests to avoid material damage.

Please check the following points again before you bring your workstation into operation.

- Have the mechanical and electrical installations been performed correctly and completely?
- Does the fuse for the device correspond to the available operating voltage? (110 V: 10 AT or 230 V: 5 AT)?
- Do the environmental conditions meet the requirements (temperature, air humidity)?
- Are you familiar with the essential laser protection regulations? Have all the laser safety measures been taken?

6 Operation

6.1 Operating and Display Elements

Control panel

In the setting-up mode, various functions may be controlled using the buttons on the operator control panel.

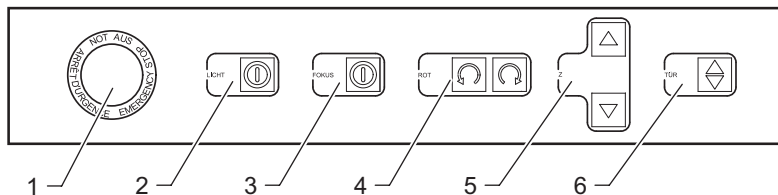

- (1) Emergency stop button
- (2) Light on/off
- (3) Focus on/off

- (4) Rotation left/right
- (5) Z axis top/bottom
- (6) Open/close door

NOTICE

Only the buttons enabled will be lit, depending on the current settings.

The rotary module is set up with the **Rotation left/right** (4) buttons.

Operation

Emergency stop button

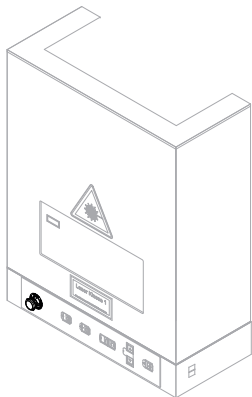

The emergency stop button is located on the left-hand side of the operating panel on the front of the device.

Stop the machine by pressing the emergency stop button whenever a situation arises which poses danger to the operating personnel or the device system.

The emergency stop button stops movements of the door and axes, and breaks the laser safety circuit.

WARNING

DANGER OF INJURIES AND/OR RISK OF PROPERTY DAMAGE.

Before releasing the emergency stop button, ensure that the cause of the danger has been rectified!

NOTICE

After the emergency stop button has been released, the workstation has to be reinitialised.

6.2 Start

NOTICE

Keep to the switching sequence on each start.

1. Start the laser marking device in accordance with the operating instructions.
2. Activate the power switch for the workstation.
3. Press the **Close door** button to initialize the workstation.
4. When the workstation is started up for the first time, you need to enter the settings for the external units in the software.
You will find more detailed information in the software manual.

6.3 Handling

The system is operated via the marking software.

All operating sequences are controlled from the control PC via the laser control interface of the laser marking device.

All the parameters are exclusively entered on the keyboard of the control computer.

This also applies to operation with the optional rotary module.

NOTICE

Opening the door breaks the laser safety circuit.

NOTICE

Detailed information for using the marking software is contained in the provided software manual.

6.4 Fault Finding

Problem/Fault	Possible cause	Elimination
Cut off	Emergency stop button pressed	Releasing the emergency stop button
Not referenced	Cover not initialised/referenced	Press the Door close button
Offline	Driver not installed	Install driver
	Device not listed in the Device manager of the operating system	Check the USB plug
	Device not switched on	Switch on the device
Axis motions very noisy	System is not aligned horizontally	Adjust the system
Door does not fully close	Foreign body in the door gap	Remove the foreign body, press the Door close button
Safety circuit open	Door not fully closed, there may be a flat foreign body in the door gap	Check and clear the door gap, press the Door close button



NOTICE

Please contact our Technical Customer Service in the first instance if the fault cannot be eliminated as described above.

7 Maintenance, Repair, Care

All maintenance and repair work must be performed exclusively by the manufacturer.
We recommend you to perform maintenance at intervals of 24 months.
The right to claim under warranty is lost as soon as third parties work on or modify the device.

Cleaning

 WARNING	
	DANGER OF INJURIES AND/OR RISK OF PROPERTY DAMAGE. Ensure that the power plug has been pulled out before starting the maintenance and cleaning work!

Clean the normally accessible areas of the workstation at regular intervals.
Do not use any sharp objects or aggressive cleaning agents for cleaning.

8 Scrap Disposal

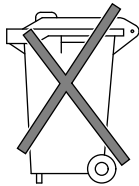

ENVIRONMENT

Protect the environment!

For a fee, the customer will accept return of the laser device and dispose of it properly in a manner that is environmentally compatible.

Environmentally sensible disposal of electrical and electronic equipment!

Electrical and electronic equipment contains valuable materials that should be supplied to recycling or recovery.

Please dispose of electrical and electronic equipment at qualified collecting points separate from municipal waste.

9 Appendix

9.1 Wiring Diagram

Connectors in working area

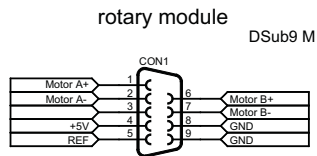
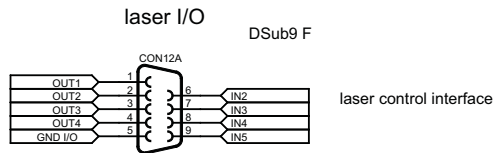
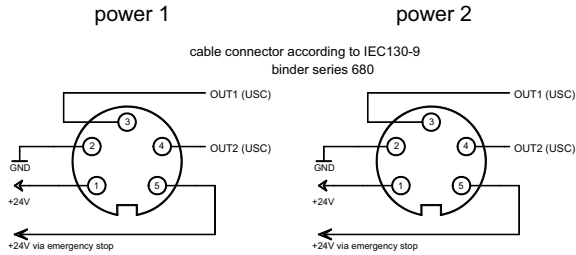

Connectors on the rear panel

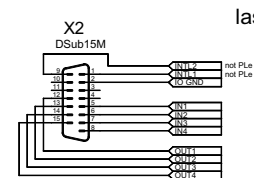
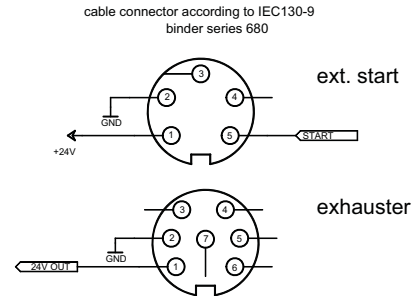

Components inside wall

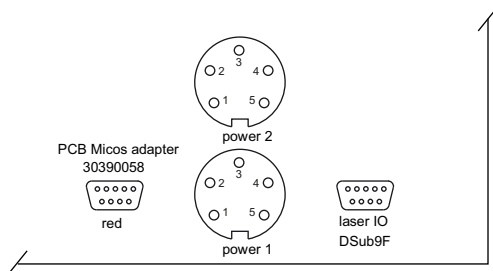

Components mounting plate rear wall

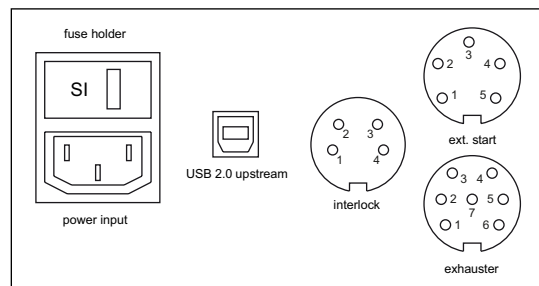

Connection laser interface

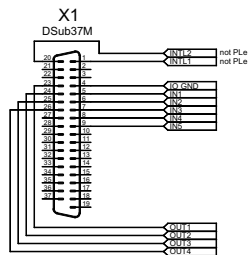

Connection laser I/O interior

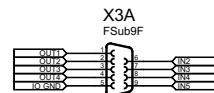

9.2 Drawing of the T-Slot Plate

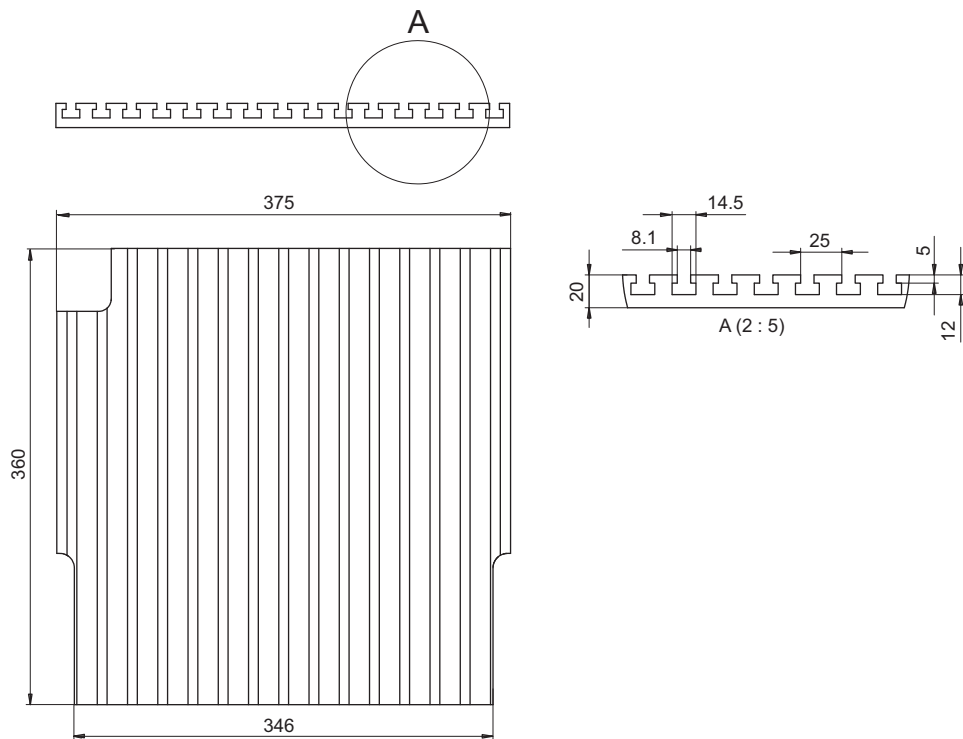

9.3 Assembly Dimensions

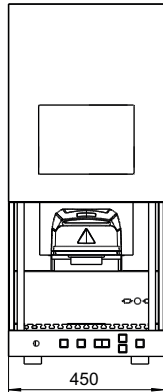
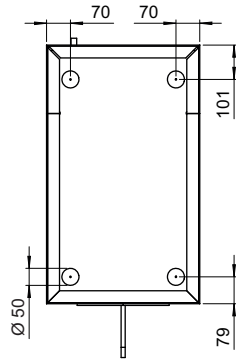

Workstation *CLASSIC* Fibre

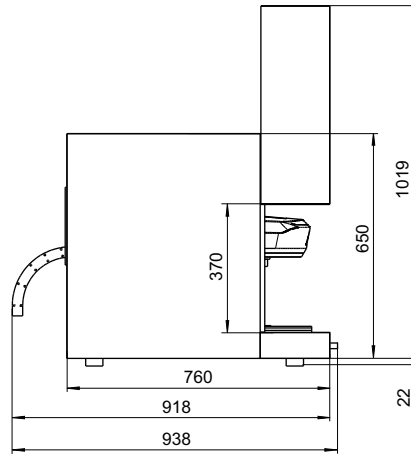

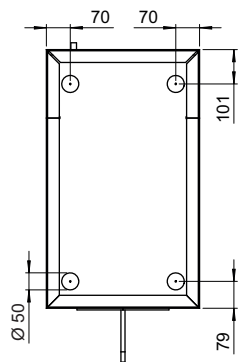

Workstation *CLASSIC* Fibre XL

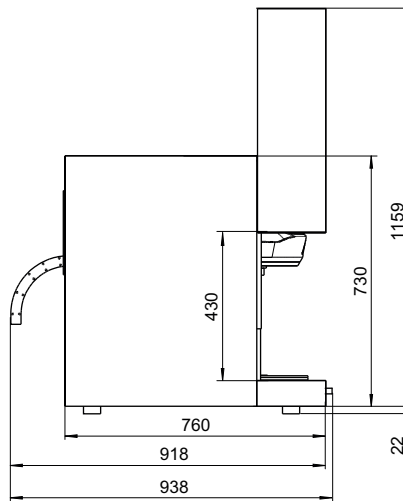
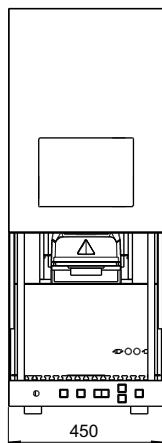

9.4 Drawing of the Axis Stroke

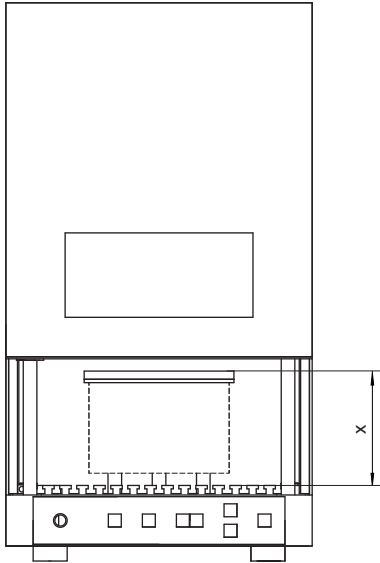

Workstation CLASSIC Fibre:

x = min. 200 mm, max. 350 mm

Workstation CLASSIC Fibre XL:

x = min. 320 mm, max. 470 mm

9.5 Illustration of the Rotary Module

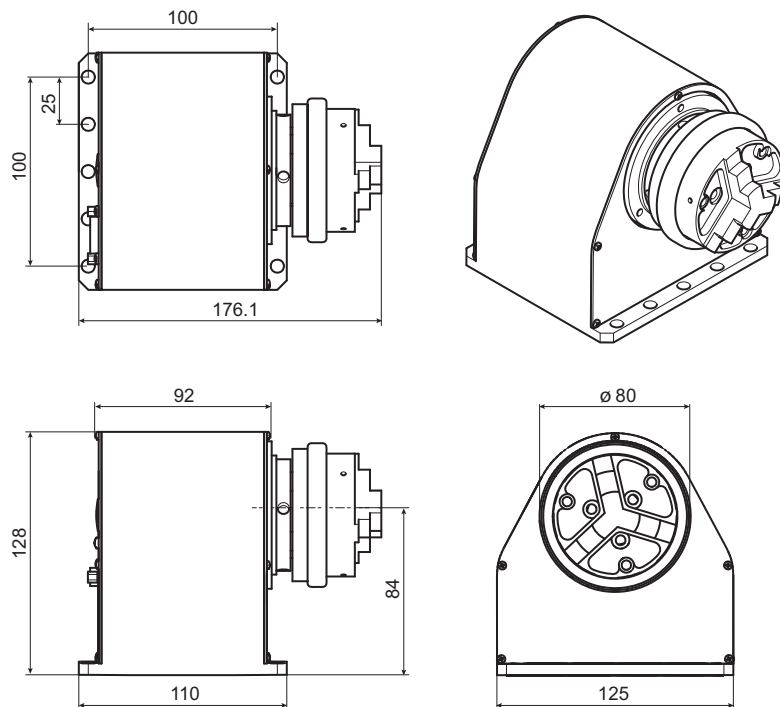

9.6 Illustration of the Working Areas

Economy/Business Fibre

F-Theta 163

F-Theta 254

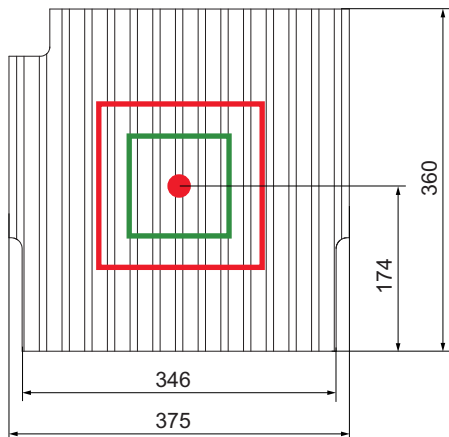

Usable mounting area

340 mm x 360 mm

Marking field = working area

F-Theta 163 110 mm x 110 mm

F-Theta 254 180 mm x 180 mm

Maximum component height

Workstation CLASSIC Fibre

F-Theta 163 150 mm

Workstation CLASSIC Fibre XL

F-Theta 163 270 mm

F-Theta 254 143 mm

9.7 EC Conformity Declaration

We herewith declare that the device described below, by virtue of its design and construction and moreover in the type brought onto the market by us, conforms to the relevant safety and health requirements of the applicable EU Directives. We further declare that the device as defined hereinbelow conforms to class laser safety class 1.

In the event of any alteration to the device or the intended purpose which has not been approved by us, this statement shall thereby be made invalid.

Device:

Laser protection housing with marking laser

Type:

Laser protection housing:

Marking laser:



Applied EC directives and standards:

Directive 2014/30/EC through

EN 55022:2010

Electromagnetic compatibility

EN 55024:2010 + A1:2015

Directive 2011/65/EU on Hazardous

EN 61000-3-2:2014

Substances (RoHS)

EN 61000-3-3:2013

EN 50581:2012

Directive 2006/42/EC through Machines

EN ISO 12100:2010

EN ISO 13857:2008

EN 349:1993+A1:2008

EN 60204-1:2006+A1:2009

EN 60825-4:2006+A1:2008+A2:2011

Representative for compiling technical documents: Mirko Wunderlich, Steinbrüchenstraße 14, 99248 Grammetal OT Nohra

Signed on behalf of the manufacturer by:

Nohra, 01.08.2019

ACI Laser GmbH

Mirko Wunderlich, Geschäftsführer

Steinbrüchenstraße 14, 99428 Grammetal OT Nohra

10 Index**A**

Air humidity (rel.) 22

B

Buttons, active 29

C

Care 14, 33

CE symbol 7

Cleaning 33

Component height 20

Connection values 21

Connection with PC 28

Connections 25

 Rear side 19

 Workroom 18

Control panel 18

Customer service 11

D

Date of manufacture 16

Defect 14

E

EC conformity declaration 43

Electrical data 21

Emergency stop button 29, 30

 Releasing 30

Emissions 13

Extraction 13, 21

Assembly	26
Connector	19
F	
Fault finding	32
Fiber laser cable	19
Focus finder function	20
Focus on/off	29
Foot switch	22
Frequency range	16
Front side view	18
Fuse	16, 21, 28
H	
Height adjustment	20
I	
Improper use	8
Instructions	14
Intended use	8
Interfaces	21
L	
Laser marking device assembly	26
Laser marking system	20
Laser protection class	12, 21
Laser protection screen	12, 16, 21
Laser safety	12
Laser safety circuit	31
Liability	8
Light on/off	29
Lighting	21

M

Maintenance	14, 33
Manufacturer	16
Manufacturer's address	11
Marking field	20
Mounting area of the T-slot plate	20

O

Open/close door	29
Operating conditions	22
Operating voltage	16, 28
Operation	14, 21, 29
Options	22

P

Positioning and repetition accuracy	20
Power connection	26
Power consumption	16, 21
Power input module	26
Power switch	18

R

Rear side	
Connections	25
View	19
Repair work	14, 33
Residual hazards	7, 15
Rotary module	41
Rotation left/right	29

S

Safety door	18, 20
-------------------	--------

Safety instructions	12
Scope of delivery	22
Scrap disposal	34
Serial number	16
Setting-up mode	29
Start up	13
Switching sequence	31
T	
Technical specifications	20
T-slot plate	18
Drawing	37
Mounting area	20
Type plate	16, 19
V	
View of device	18
Viewing window	18
W	
Warning signs	15
Warranty	10, 33
Weight	22
Wiring diagram	35
Working area	20
Working temperature	22
Workroom	18
Connections	25
Z	
Z axis	20, 29



Operating Instructions for **Workstation CLASSIC Fibre/Workstation CLASSIC Fibre XL**

Article number: 10002189

Version: EN 08/2019-03

ACI Laser GmbH
Steinbrüchenstraße 14
D-99428 Grammetal OT Nohra

Phone: +49 3643 4152-0
Fax: +49 3643 4152-77
info@ACI-Laser.de
www.ACI-Laser.de

Mark your territory...