

LASER MARKING SYSTEMS



Operating Instructions

DPL *Smart* Marker I
DPL *Smart* Marker II
Economy *Diode*

OEM Version
Laser Device Class 4



Mark your territory...

This product conforms to the requirements of the Machinery Directive 2006/42/EC.
The CE symbol is located on the type plate.

Manufacturer: ACI Laser GmbH
Steinbrüchenstraße 14
D-99428 Grammetal OT Nohra
Germany

Phone: +49 3643 4152-0
Fax: +49 3643 4152-77
info@ACI-Laser.de
www.ACI-Laser.de

We are constantly working on further developments.

Therefore, please understand that we must reserve the right to change the scope of the delivery in respect of the form, equipment and technology at any time.

Reprinting, copying or translating this document in whole or in part is forbidden without the express written permission of ACI Laser GmbH!

All rights under the copyright laws are expressly reserved by ACI Laser GmbH.

The manufacturer shall only be responsible for the safety characteristics of this device within the scope of the legally applicable regulations if it is operated by the user in accordance with the operating instructions and repaired by ACI Laser GmbH itself or someone appointed by and acting under the instructions of ACI Laser GmbH.

Last update: 02/2019-02

© ACI Laser GmbH

Table of Contents

1	Introduction	7
2	Important Information	7
2.1	Intended Use	8
2.2	Improper Use	9
2.3	Notices in the Document	9
2.4	Warranty	11
2.5	Technical Customer Service	12
3	Safety	13
3.1	Basic Safety Instructions	13
	Functional safety	13
	Laser class	13
	Emissions	14
	General	15
	Initial start-up	15
	Operation	16
	Maintenance/Care	16
3.2	Labels at the Device	17
	Warning notices	17
	Type plate	18
4	Description	19
4.1	Overview	19
4.2	Intended Purpose	20
4.3	Principle of Operation	21
	Laser beam source	21
	Shutter	21
	Pilot laser	21
	Beam deflection	21
	Laser electronics	22

Table of Contents

	Laser Safety Device (SD)	22
4.4	Technical Data	24
	Laser device	24
	Connection values	24
	Fuse protection	24
	Interfaces	24
	Scan unit	25
	Focusing objectives (optional)	25
	Beam source dimensions incl. scanner	25
	Operation and storage conditions	25
	Technical drawing	26
4.5	Scope of Delivery	28
5	Installation	29
5.1	Unpacking	29
5.2	Mechanical Installation	30
	Assembly	31
	Focusing	32
5.3	Installing the Marking Software	33
	Minimum hardware requirements	33
	Installation	33
5.4	Electrical Installation	34
5.4.1	Interfaces	34
	Interlock connection	35
	Laser control interface	37
5.4.2	Connection	39
	Power connection	39
	Connection with the PC	39
5.5	Checking the Installation	40
6	Operation	41
6.1	Operating and Display Elements	41

	Control elements	41
	Multi function display	42
6.2	Starting the Laser Marking Device	43
6.3	Handling	44
6.4	Fault Finding	44
6.4.1	General Faults	44
6.4.2	Specific Faults	46
7	Maintenance and Repair	49
7.1	Care	49
	Cleaning the objective	50
	Cleaning the ventilation slits	51
7.2	Maintenance, Repair	52
	Maintenance intervals	52
8	Scrap Disposal	53
9	Detailed Advanced Information	54
9.1	DPL Smart Marker I/II, a highly integrated Marking System	54
9.2	Design and Function	54
	Preliminary remarks	54
	Basic terminology	55
9.2.1	Laser Beam Source	57
9.2.2	Q-switch	59
	Continuous wave mode (cw)	59
	Pulse operation	59
9.2.3	Beam Deflection	59
9.2.4	Plane Field Objective	60
	Field correction	60
9.2.5	Laser Control	61
	Power supply	61
	Control system	61
	Interfaces	61

Table of Contents

9.2.6	Marking Software	62
9.3	Laser Beam Quality	63
	Multimode laser	63
	DPL Smart Marker I/II	64
9.3.1	Pulse Power Density	65
9.4	Thermoelectric Air Cooling	66
9.4.1	Design	66
	Principle of operation of a Peltier element	66
9.4.2	Cooler Dimensioning	67
	Cooling the laser diode	67
	Temperature stabilisation of the resonator	67
9.5	The Materials Science of Laser Marking in Brief	68
9.5.1	Pulse Overlapping	69
	Example 1	69
	Example 2	70
9.5.2	Marking Methods	70
	Heating	70
	Melting	70
	Vaporisation	71
	Removal	71
9.5.3	Materials	71
	Metals	71
	Plastics	72
	Laser foils	72
10	Appendix	73
10.1	Saturation Vapour Pressure as a Function of the Temperature	73
10.2	EC Declaration of Incorporation	75
10.3	EC Declaration of Conformity	76
11	Index	77

1 Introduction

Dear customer,

thank you for the confidence which you have shown in us by purchasing our quality product. We would like to wish you every success with the use of the device.

Make yourself familiar with these operating instructions before starting use. The operating instructions tell you how to use your new device correctly and safely, and take you step by step through the actions which have to be performed before using it for the first time.

2 Important Information

Our Products are developed and manufactured under strict quality monitoring to give a long and fault-free service life.

This guarantees:

- highest quality and a long life,
- easy and safe operation,
- functional design,
- optimisation for the intended purpose.

The **DPL Smart Marker I/II** is a state-of-the-art device. The EC Declaration of Incorporation and the EC Declaration of Conformity confirm that the manufacturer has complied with the relevant directives. The CE-symbol is located on the type plate.

The laser marking device contains a class 4 laser according to DIN EN 60825-1 "Safety of Laser Devices".

Should the operating company integrate the device as an OEM component into an existing installation, it shall bear the sole responsibility for fulfilling the standards and directives. This includes, for example, fitting it into a laser protection hood or integrating it into a production line.

The company operating the laser marking device is **obliged** to implement the safety measures arising from DGUV no. 11 "Laser Radiation" and from DIN EN 60825-4 "Safety of Laser Devices".

Please read these operating instructions carefully from the beginning in order to avoid errors and risks.

Reference is made to residual hazards at the relevant places in the operating instructions. Please also take note of the warning notice stickers on the device.

2.1 Intended Use

- The operating company is obliged to appoint a laser safety officer in accordance with para. 6 of DGUV no. 11 "Laser Radiation" to ensure that the relevant safety guidelines and standards are observed.
- The **DPL Smart Marker I/II** laser marking system is intended to be used exclusively for marking applications in conjunction with the associated **Magic Mark** software. The performance parameters must be adapted to suit the properties of the materials to be marked.
- The laser marking device is intended for integration into installations or lines. Please contact the customer for information about other possible applications.
- Usage for the intended purpose includes observance of these operating instructions, the instructions in the software manual and the warning stickers on the device.
- The supplier/manufacturer shall not be liable for personal injury or material damage resulting from improper use of the laser itself or the safety devices.

2.2 Improper Use

All other uses other than use for the intended purpose, including that with other control software, shall be deemed to be improper use.

The laser marking device must not be used by:

- persons who have not read or understood these operating instructions,
- persons who have not been instructed in the proper operation,
- persons who are under the influence of alcohol and or drugs, or
- persons whose alertness is impaired by medicines or other influences.

The laser marking device must not be used:

- if the required protective devices have not been provided according to para. 4 of DGUV no. 11 "Laser Radiation",
- if protective/safety devices are bridged, defective or if they cannot reliably fulfil their function,
- if there is a suspicion that direct or leakage radiation can emanate.

2.3 Notices in the Document

Take note of the warning notices, take the specified actions and observe the prohibitions. A warning notice warns of a possible hazard and contains recommendations for preventing the hazard occurring. Key words indicate the type of hazard, symbols emphasize this visually.

Follow the stated measures for preventing hazards to the operator or tangible assets.

The following classification of dangers are used in these safety instructions:

DANGER

RISK OF DEATH OR SERIOUS INJURIES!

Indication of an imminent danger, which will result in death or serious injuries if the appropriate precautionary measures are not taken.

WARNING

DANGER OF INJURIES AND/OR RISK OF PROPERTY DAMAGE.

Indication of an immediately impending hazard which can cause serious injuries or property damage if the appropriate precautionary measures are not taken.

CAUTION

RISK OF PROPERTY DAMAGE.

Indication of a possible hazard which may cause damages of the equipment if the appropriate precautionary measures are not taken.

Additional information on working with the laser marking device and protection of the environmental are emphasised as follows:

NOTICE

Useful additional information and tips!

ENVIRONMENT

**Protect the environment!
Instructions for observing environmental protection regulations!**

2.4 Warranty

The manufacturer guarantees that the product does not have any manufacturing or material defects.

The warranty period shall be 12 months from the dispatch date in as far as no other contractual ruling has been made.

The scope of warranty is limited to the repair or replacement of the product supplied by the manufacturer.

The manufacturer is responsible for returning repairs under warranty to the customer, the customer is responsible for returning the device to the manufacturer.

The manufacturer does not accept any liability under warranty

- if the product has been damaged by incorrect handling or operation, or as a result of improper use,
- if seals on the device have been broken,
- for damage caused by use under unauthorised environmental conditions,
- for damage to the device if it is not returned in its original packaging,
- for consequential damage.

2.5 Technical Customer Service

ACI Laser GmbH
Steinbrüchenstraße 14
D-99428 Grammetal OT Nohra
Germany

Phone: +49 3643 4152-0
Fax: +49 3643 4152-77
service@ACI-Laser.de
www.ACI-Laser.de

NOTICE

The laser device may only be maintained and repaired by the manufacturer. Any manipulations on the device or breaking the warranty seal will void any claims under warranty.

3 Safety

3.1 Basic Safety Instructions



The following safety instructions have fundamental importance for the use of the laser marking device, and for its care and maintenance. They must always be followed and are only stated centrally here.

Functional safety

In order to realise functional safety, the laser marking devices of ACI product group, **Economy Diode**, contain the safety module, "laser safety device" (hereinafter also referred to as SD). It is classed in category 3 and achieves performance level (PL) e according to the DIN EN ISO 13849-1 standard.

Characteristics according to DIN EN ISO 13849-1:

Performance Level:	e
Category:	3
MTTF _d :	> 67 years
DC _{avg} :	mean (90% - 99%)

Based on the useful life of the shutter module (swivelling diaphragm), this module must be replaced after 14 years, at the latest, in order to maintain performance level e.

Laser class

As an OEM component, the **DPL Smart Marker I/II** is a class 4 laser marking device according to DIN EN 60825-1 "Safety of Laser Devices".

- The accessible laser radiation is very dangerous to the eyes and skin.
- Even diffuse, scattered laser radiation can be dangerous if the accessible radiation exceeds the class 1 threshold.
- Improperly used laser radiation may lead to a risk of fire or explosion.

The following measures must be taken in order to be able to categorise the **DPL Smart Marker I/II** as a class 1 laser device (accessible laser radiation is harmless):

- Ensure that the entire beam path to the work piece is shielded beam-tight.
- Those parts of the screening which can be removed without tools must be fitted with safety switches which interrupt the beam path before the laser beam leaves the device.
- Viewing windows (e.g. in the enclosure or the screening) must be fitted with laser protection glass appropriate for the wavelength and the laser power class.

The guidelines stated in DIN EN 60825-4 "Safety of Laser Devices" and DGUV no. 11 "Laser Radiation" must be implemented if the accessible laser radiation cannot be reduced to below the class 1 threshold values when the device is integrated into the installation.

Emissions

- If the design of the installation prevents the requirements for class 1 laser devices being fulfilled, the area around the laser system must be protected by
 - adjustable walls,
 - light signals and
 - warning noticesso that adequate notice is given of the danger before the area is entered.
- Install a second emission warning light in the view of the operator. During operation, this signals that the beam catcher (shutter) arranged in the laser beam path is open. The shutter consists of a screen which can be swivelled into the beam path, so interrupting the laser process.
- Chemical and physical reactions during the laser marking can cause
 - gases,
 - vapours,
 - aerosols,
 - dusts,
 - mists or

- other reaction products
to be given off from the material surface.

These may be toxic, depending upon the material being processed. The operating company must therefore provide effective extraction. Information about this can be found, for example, in the VDI guideline 2262 1...3 "Air Quality in the Work Place".

- Please contact the manufacturer with regard to relevant accessories and protective equipment.
- Read the operating instructions and always keep them in an accessible place.
- Do not mark any easily flammable or combustible materials.
- Do not transport, store or operate the device in a vertical position. There is a risk of damaging optical components.

General

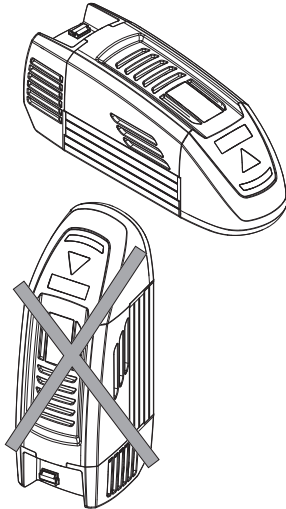

Initial start-up

- The ambient temperature must lie within the range of 20 °C and 30 °C. The condensation temperature as a function of the momentary relative air humidity must be < 20 °C.

Safety

You will find an instruction for estimating the momentary value in the appendix.

- Ensure that the relative air humidity does not exceed 85%.
- Never start the device immediately after large temperature changes. Condensation water may damage the device.
- Ensure that an adequate air supply can be provided at the location of the supply unit and that none of the vents are covered.
The vents must be clear and free of any residual packing material.
- Mount the device at the installation site in accordance with the regulations.
- Ensure that the shutter is active (closed) during the set up.
The main beam is simulated by a pilot laser.
The laser is not harmful to the skin. The eyes are protected by the natural blink reflex.

Operation

- The laser marking device may only be operated by trained personnel.
It is advisable to log both the initial training as well as the regular refresher courses.
- The device may only be operated when connected to an alternating voltage supply corresponding to the specifications on the type plate.
- The effectiveness of the protective conductor must be regularly checked and confirmed by an authorised skilled worker.
- If a defect occurs in the laser marking device, it must be disconnected from the power supply system and secured against being switched on again.

Maintenance/Care

- Maintenance and repair work on the laser device may only be performed by the manufacturer.
- The device must be disconnected from the power supply system before the covers are removed.
- Do not touch the electrical/electronic components. Capacitors could still be charged and so be under voltage.

3.2 Labels at the Device

Warning notices

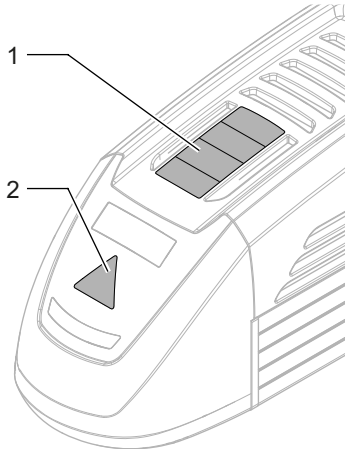

The warning notices on the device point out possible hazards from the laser and provide information about the basic performance data of the laser units.

- On the top of the enclosure (1):

DPL Smart Marker I

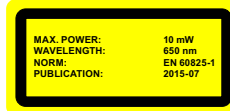
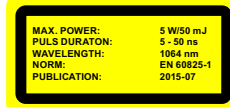
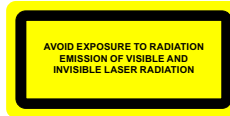

DPL Smart Marker II

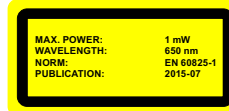
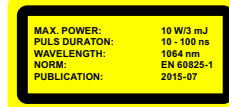
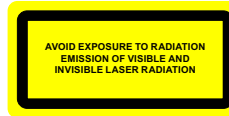

- On the beam outlet cover (2):



Type plate

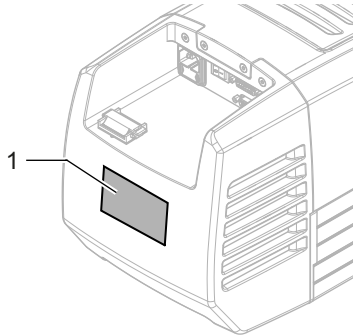

The type plate (1) on the back of the laser marking device contains information about:

- series number,
- manufacturer,
- date of manufacturing,
- operating voltage/frequency range,
- power consumption and
- device fuse.

ACI Laser GmbH
Steinbrüchenstraße 14
99428 Grammetal OT Nohra
Germany
phone: + 49(0)3643 4152-0
fax: + 49(0)3643 4152-77
www.ACI-Laser.de
info@ACI-Laser.de



Model:
Serial Number:
Manufacturer:
Date of Manufacturing:
Line Voltage:
Max. rated power:
Fuse:

DPL Smart Marker I
2001S598
ACI Laser GmbH
01/2020
100-240VAC, 50-60Hz
300W
230V/2 x 2,5AT
110V/2 x 5,0AT



Vor Öffnen des Gehäuses Netzstecker ziehen!
Disconnect power before opening cover!
Avant d'enlever le capot débrancher l'appareil!

ACI Laser GmbH
Steinbrüchenstraße 14
99428 Grammetal OT Nohra
Germany
phone: + 49(0)3643 4152-0
fax: + 49(0)3643 4152-77
www.ACI-Laser.de
info@ACI-Laser.de



Model:
Serial Number:
Manufacturer:
Date of Manufacturing:
Line Voltage:
Max. rated power:
Fuse:

DPL Smart Marker II
2001S598
ACI Laser GmbH
01/2020
100-240VAC, 50-60Hz
400W
230V/2 x 2,5AT
110V/2 x 5,0AT



Vor Öffnen des Gehäuses Netzstecker ziehen!
Disconnect power before opening cover!
Avant d'enlever le capot débrancher l'appareil!

4 Description

4.1 Overview

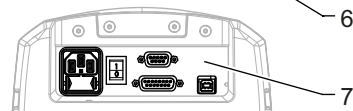
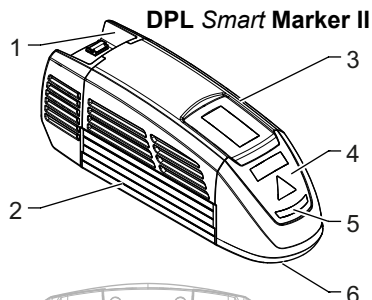
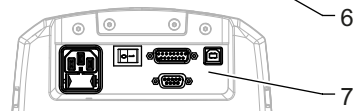
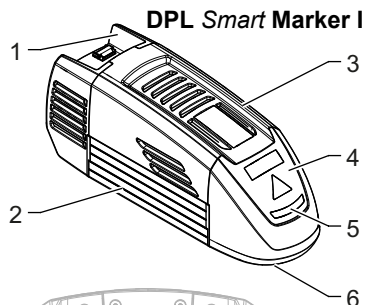

The functional units of the laser marking device contain the following components:

- (1) laser diode with thermoelectric air cooling
- (2) optical bank consisting of:
lens system,
resonator with laser crystal, mirror system, Q-switch and
shutter (beam catcher)
- (3) laser electronics
- (4) galvanometer scan unit
- (5) multi function display
- (6) objective (laser beam outlet)
- (7) power input module and interfaces

4.2 Intended Purpose

The object of marking a work piece is to produce a marking with the following properties:

- durability,
- high contrast,
- high resolution,
- minimal stress on the material and
- minimal change in its properties.

These requirements are optimally fulfilled by the **DPL Smart Marker I/II**.

The laser marking device is a highly-integrated marking system. The components

- optics,
- control electronics,
- thermoelectric air cooling

are located in a compact functional unit.

In contrast to other comparable systems, the **DPL Smart Marker I/II** guarantees:

- The easiest integration into existing production lines because of its small dimensions and low weight.
- Increased operational safety by the elimination of external electrical and fiber-optic connections between the components.
- Increased operational safety by the elimination of complex water-air-cooling units.
- Minimising the down times and maintenance costs by replacing the complete functional unit during maintenance and service work.

4.3 Principle of Operation

Laser beam source

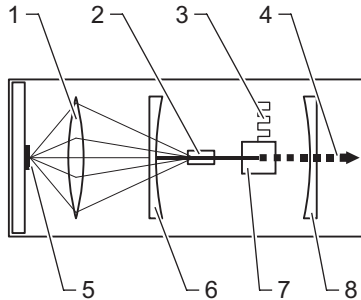

The laser beam source comprises a resonator for beam generation and amplification.

The radiation of a laser diode (5) focused through a lens (1) excites a laser crystal (2). This, together with the following Q-switch (7), is positioned on the optical axis between the mirrors (6) and (8).

The excited laser crystal (in this case a Nd:YAG) emits a continuous high-energy beam with a wavelength of 1064 nm.

The laser beam is switched on and off with a pulse frequency (3) to 1 Hz - 100 kHz by passing it through a Q-switch in order to achieve the energy density on the material to be marked that is required for the field of application. This achieves a power amplification of several orders of magnitude.

A easily-focusable, pulsed laser beam (4) with an ideal energy distribution over its cross-section is available at the beam outlet.

Shutter

A swivelling screen is arranged in the resonator. The laser process is interrupted by closing the shutter.

Pilot laser

The wavelength of the working laser is not in the visible range. The light of a low power red laser diode is reflected into the beam path between the shutter and scanhead to check the marking window.

This enables the positions of the marking window to be made visible when the shutter is closed.

Beam deflection

The focusing point of the laser beam has to be deflected in the x and y directions in order to mark greatly differing materials. This is achieved by the deflection units of a galvanometer scanner.

Focusing is assisted by one of three alternative plane field objectives, whose focal length determines the size of the marking field and the spot diameter.

Description

Laser electronics

The internal laser control monitors and regulates the entire process of beam generation and deflection. It communicates with the controlling PC via an USB interface.

Its information and commands are evaluated and executed.

The laser marking device has a laser control interface with active 24 V I/O signals as an interface to external systems.

Laser Safety Device (SD)

The laser safety device (SD) is the central safety module of the laser marking devices of the ACI product group, **Economy Diode**. It meets the requirements for the safety feature according to the DIN EN ISO 13849-1 standard, performance level e.

The safety feature consists of the redundant control and continuous monitoring of the two output paths (diaphragm/shutter, protective relay) as well as continuous monitoring of the input paths (interlock circuits, ILK1 and ILK2). This ensures at all times that, in the event of error, emission of laser radiation due to opening of the interlock circuits is prevented.

Opening the interlock circuits will immediately cause the diaphragm to swivel into the beam path, thus interrupting the laser process.

In the event of the following errors:

- Exceeding the defined time period of 200 ms upon opening or closing the diaphragm,
- Short circuit or interruption of the interlock circuits,
- Exceeding the defined time period of 150 ms upon switching the two interlock circuits,
- Overvoltage or undervoltage in the SD power supply,
- Internal SD error

in addition to closing the diaphragm, the protective relay is switched off, thus disconnecting the entire laser marking device from the power supply. Only the laser electronics continues to be supplied with power, thus allowing communication with the user application; hence, display or analysis of the error cause.

A system that was switched off due to an error can be put into operation again only by switching it off and on again, provided that the error cause has been removed.

The SD checks all safety-relevant features upon switching on the laser marking device. Only in the absence of errors will the protective relay be activated, thus starting up the laser marking device. If the SD detects errors in the instant of switching on, then these will also be forwarded to the user application via the laser electronics.

Description

4.4 Technical Data

Laser device	Diode pumped, actively Q-switched solid-state laser
Laser material:	Nd:YAG
Wave length:	1064 nm
Laser power:	4 W/10 W
Pulse repetition rate:	1 - 80 kHz
Pilot laser:	650 nm, < 1 mW
Laser class:	4
Performance level:	e
Connection values	Power supply: 85 - 264 VAC/6 A/50 - 60 Hz
	Power consumption (typical): 150 W/200 W
	Power consumption (max.): 300 W/400 W
Fuse protection	110 VAC: 2 x 5 AT
	220 VAC: 2 x 2.5 AT
Interfaces	Power supply: 3-pin socket with fine-wire fuse
	PC interface: USB 2.0
	Interlock connection: - dual-circuit interlock - SD-Ready
	Laser control interface for: - external emission light - Signal Ready - 4 freely programmable in-/outputs

Scan unit	Aperture:	9 mm
	Scanning speed:	< 2 m/sec
Focusing objectives (optional)	F-Theta 100	
	Spot diameter ⁽¹⁾ :	25 µm
	Marking field size:	60 mm x 60 mm
	Focusing length ⁽²⁾ :	138 ± 3 mm from lower edge of scan unit
	F-Theta 163	
	Spot diameter ⁽¹⁾ :	35 µm
	Marking field size:	110 mm x 110 mm
	Focusing length ⁽²⁾ :	220 ± 3 mm from lower edge of scan unit
	F-Theta 254	
	Spot diameter ⁽¹⁾ :	50 µm
	Marking field size:	180 mm x 180 mm
	Focusing length ⁽²⁾ :	384 ± 6 mm from lower edge of scan unit
	⁽¹⁾ Deviations may occur with different materials.	
	⁽²⁾ The exact value for distance is stated in the parameter file supplied with each device.	
Beam source dimensions incl. scanner	Length x width x height:	603 mm x 201 mm x 235 mm / 654 mm x 201 mm x 237 mm
	Weight:	15 kg/16 kg
Operation and storage conditions	Operating temperature:	25 °C ± 5 °C
	Storage temperature:	10 °C - 50 °C
	Air humidity:	30% - 85%, non-condensing

Description

Technical drawing

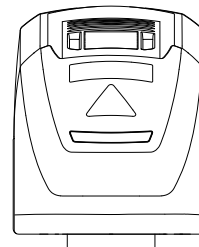
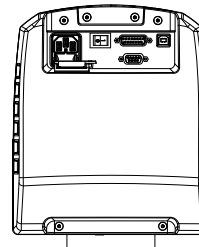
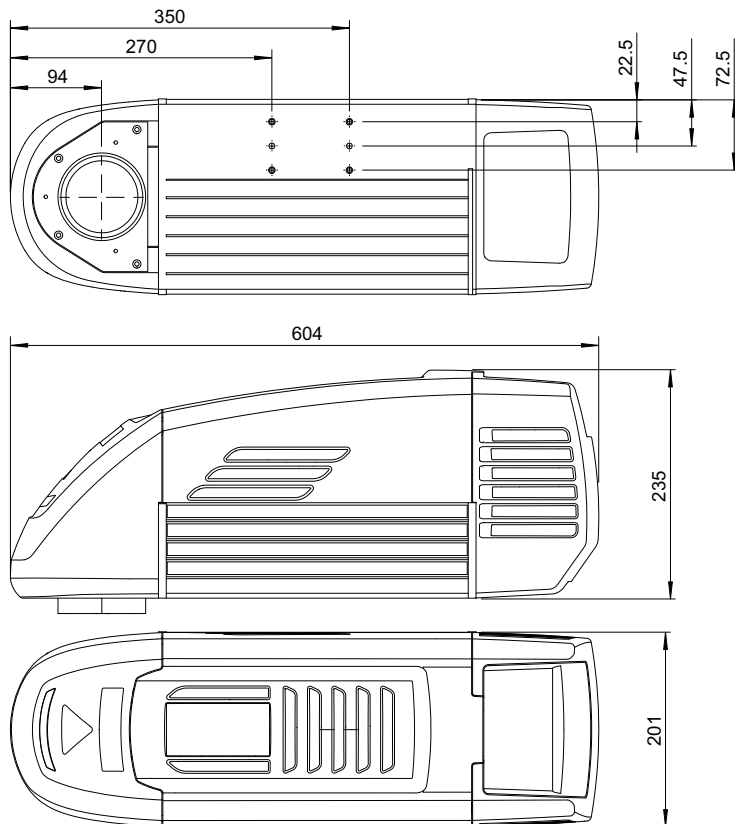

DPLSmart Marker I

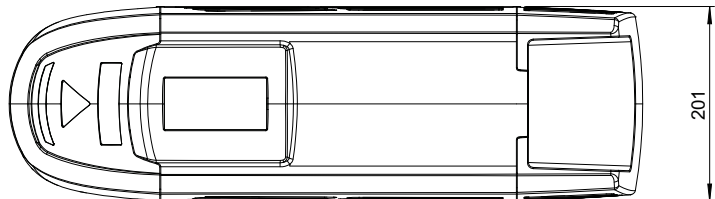
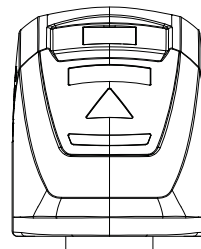
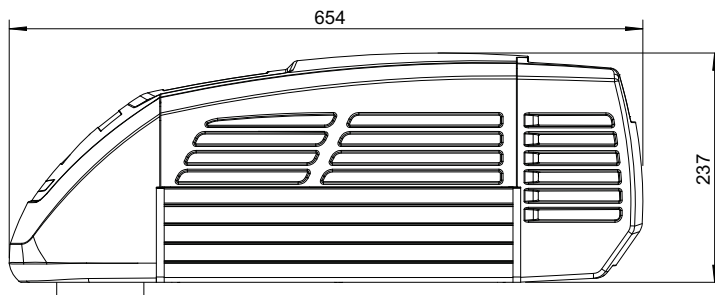
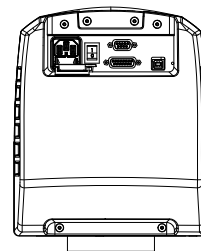
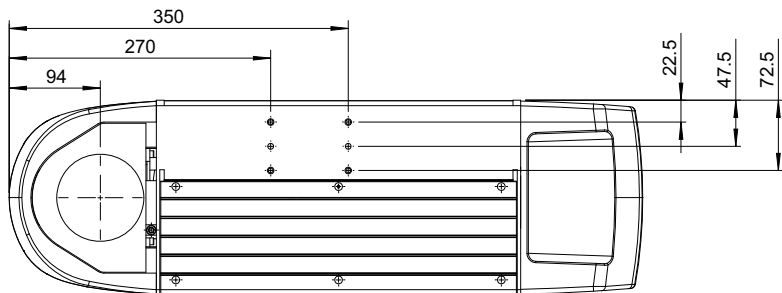

DPL *Smart* Marker II

4.5 Scope of Delivery

- The **DPL Smart Marker I/II** laser device completely mounted,
- power cable,
- connection cable for USB 2.0,
- 15-pin sub-D housing to wire the laser control interface,
- 9-pin sub-D housing to wire the interlock connection,
- CD ROM with Marking software,
- operating instructions,
- software manual.

NOTICE

Check that the delivery is complete and undamaged. Please contact our service department if you have any queries.

5 Installation

5.1 Unpacking

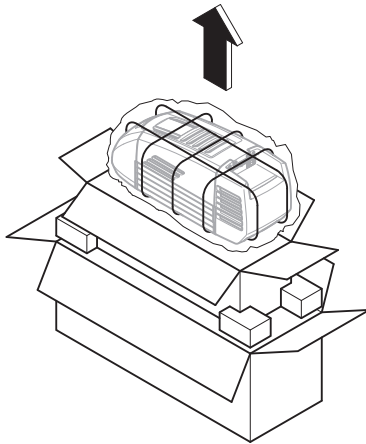

The laser marking device is delivered in a packaging which meets UPS "falling regulations".

From the inside outwards:

- **DPL Smart Marker I/II** laser device completely mounted,
- foam grid,
- vacuum-tight, welded aluminium foil with desiccant,
- inner carton,
- foam corners,
- outer carton with accessories included in the scope of delivery.



1. Open the carton on the top. Take note of the marking **OBEN (TOP)**!
2. Remove the laser marking device in its packing material and put it down in a safe place.
3. Open the foil packing and pull it off.
4. Remove the foam grid from the device.
5. Place the device on a flat surface.
6. Remove the accessories and place them down.
7. Check the scope of delivery for completeness.

NOTICE

Store the packaging material in a safe place in case the device has to be returned to the manufacturer under warranty for maintenance and repair work.

In such a case repack the laser marking device into its original packaging in the reverse order and seal it securely.

5.2 Mechanical Installation

 WARNING	
	<p>RISK OF PERSONAL INJURIES AND MATERIAL DAMAGE FROM LASER RADIATION!</p> <p>All safety-related devices must be installed and their effectiveness proven before the system is started up. The acceptance must be performed by the laser safety officer and recorded in writing.</p> <p>For safety reasons, the laser must not be activated until all the above-mentioned conditions have been fulfilled.</p>
 CAUTION	
<p>RISK OF DAMAGING THE OBJECTIVE!</p> <p>Leave the protective cover on the objective throughout the entire installation.</p>	

Assembly

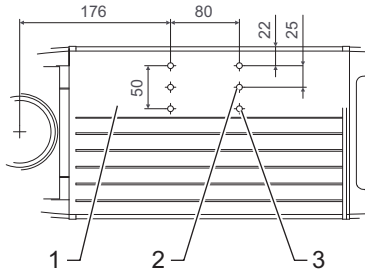

A mounting surface (1) is provided on the underside of the device to enable it to be mechanically integrated into a system.

The position of the bore holes (measured in mm) for

- 4 x M6 fixing screws (3) with washers/ tooth lock washers
- 2 x alignment pins (2) $\varnothing 6$ H7

can be seen in the drawing on the left.

NOTICE

The above-mentioned standard parts are not included in the scope of delivery. Take note of the maximum screw depth of 8 mm.

The length of the bearing surface on the system side should be at least 100 mm.

NOTICE

The manufacturer recommends fitting in a horizontal position.

Installation

Focusing

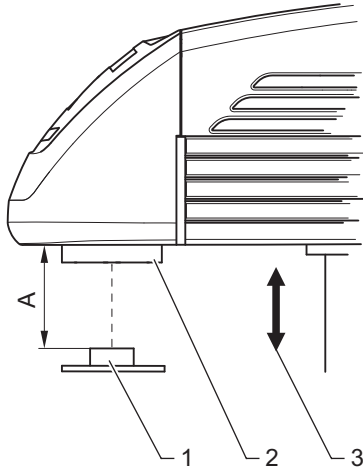

NOTICE

A defined distance between the objective of the scan head and the work piece must be set in order to focus the laser beam optimally on the surface of the work piece.

The distance (A) between the lower edge of the scan unit (2) and the surface of the work-piece (1) depends upon the type of objective used:

- F-Theta 100: A = 138 ± 3 mm
 Marking field size: 60 mm x 60 mm
- F-Theta 163: A = 220 ± 3 mm,
 Marking field size: 110 mm x 110 mm
- F-Theta 254: A = 384 ± 6 mm
 Marking field size: 180 mm x 180 mm

NOTICE

The exact value for distance (A) is stated in the parameter file supplied with each device!

The availability of a suitable height adjustment (3) is a useful aid when focusing.

5.3 Installing the Marking Software

Minimum hardware requirements

- PC with 64 bit operating system Windows 7 or 10,
- CD ROM drive,
- 1 free USB 2.0 interface,
- monitor (recommendation: 17 inch),
- keyboard, mouse.

If necessary, you will receive this additional information from the manufacturer.

Installation

1. Start your PC.
2. Ensure that the above-mentioned operating system is installed on your PC.
3. Place the CD labelled **Magic Mark** into the CD drive.
4. Open the directory **Magic Mark** in Explorer with a double click.
5. Start the setup.exe by double-clicking.
6. Follow the instructions of the installation program.
The following message appears when the installation has been completed:
Setup Complete.
7. Confirm this by pressing the **ENTER** key.
8. Start your PC again.

NOTICE

You will find detailed instructions for configuring the marking system in the Software Manual.

Installation

5.4 Electrical Installation

5.4.1 Interfaces

WARNING



DANGER OF INJURIES AND/OR RISK OF PROPERTY DAMAGE!

The device interfaces may only be connected to the plant by an electrician in cooperation with a laser safety officer!

DPL Smart Marker I

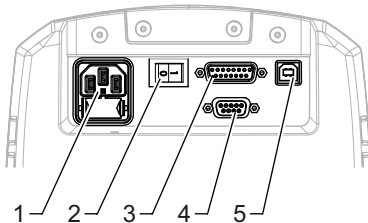

DPL Smart Marker II

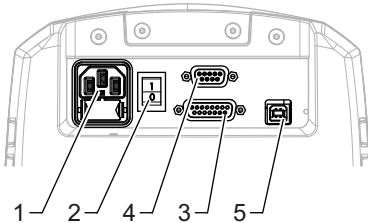

The interfaces are located on the back above the laser diode module:

- (1) the power input module with integrated power switch and drawer for fine fuses
- (2) power switch
- (3) laser control interface, 15-pin, sub-D, panel socket as an interface to the plant/line
- (4) interlock connection, 9-pin, sub-D
- (5) USB 2.0 interface, for communication between control PC and laser marking device

Interlock connection

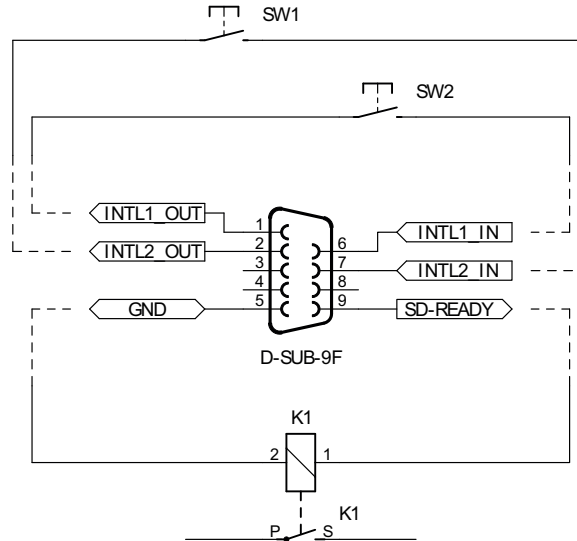

Interlock circuit 1 and 2

Pin 1, pin 6 INTL1_OUT, INTL1_IN
external interlock circuit 1

Pin 2, pin 7 INTL2_OUT, INTL2_IN
external interlock circuit 2

In order to integrate the laser marking device into an external, dual-channel, safety circuit, 2 potential-free independent safety switches must be wired between pin 1/6 and pin 2/7 (see image).

To this end, it must be ensured (mechanically) that both switches reliably within a period of 150 ms.

Alternatively for the use of potential-free safety switches, it is possible to use a safety relay based on Performance Level e with appropriate wiring in accordance with the manufacturer's specifications.

Please use a shielded, four-wire cable with a wire cross-section of at least $4 \times 0.5 \text{ mm}^2$ to connect the interlock circuits and connect the diaphragm located on the plug connector of the laser marking device to connector housing and earth (pin 5).

Pin 9 **SD-READY**
24 V, max. 100 mA, short-circuit proof

Pin 5 **GND**
Reference for SD-READY

When the laser safety device (SD) is ready for operation, pin 9 carries 24 V against pin 5. Connecting a suitable indicator light or a switching element allows readiness for operation and absence of errors in all safety-relevant components to be signalled to the user, respectively the overriding control.

For connection, please use a shielded, two-wire cable with a wire cross-section of at least $2 \times 0.5 \text{ mm}^2$ and connect the diaphragm located on the plug connector of the laser marking device to connector housing and earth (pin 5).

If possible, the end points of connected cables should also be connected to earth, respectively earth potential (protective conductor).

Laser control interface

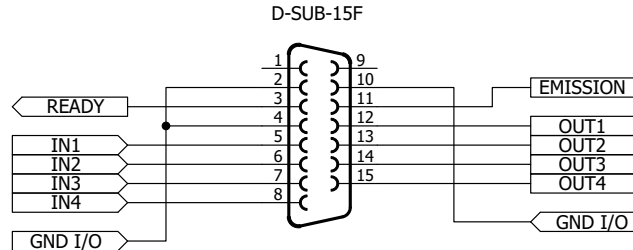

The Laser control interface is realised by a 15-pin, sub-D, panel socket, two-rowed. Depending upon the application case, the laser control interface may be wired by the user.



External emission light

Pin 11 **EMISSION**
 24 V, max. 200 mA, protected by polyfuse.

Pin 11 carries 24 V when the shutter is open.
 The connected emission warning light signals danger from laser radiation.

 WARNING	
	<p>DANGER OF INJURIES AND/OR RISK OF PROPERTY DAMAGE FROM LASER RADIATION!</p> <p>Wiring this output is specified for operation in accordance with a class 4 laser.</p>

Emission ready

Pin 3 **READY**
24 V, max. 200 mA, protected by polyfuse.

This output produces a composite signal of all possible error states. The output is set when all components function within normal parameters and the laser is ready for operation. This signal can be processed both optically and electronically. This output is an essential aid, particularly for use in production lines.

Inputs and outputs

Pin 5 to 8 **IN1 to IN4**
24 V, 3.5 mA
Control inputs for the PLC connector

Pin 12 to 15 **OUT1 to OUT4**
24 V, max. 0.5 A
electronically secured, short-circuit-proof, inductive loads may be connected. There is an internal freewheel diode.

Pin 2, 4, 10 **GND I/O**
Reference points for all 24 V inputs and outputs as well as READY and EMISSION

The inputs can be queried during a marking cycle and so start e.g. a marking job. The freely programmable outputs can, for example, be used to indicate the end of an inscription. Please refer to the software manual for information concerning the processing of signals by the marking software.

NOTICE

Current limitation: There is a common limit to the current for all outputs. If the maximum permissible current (0.55 A) is exceeded, all the outputs are switched off (see page 47 Overload I/O).

5.4.2 Connection

Power connection

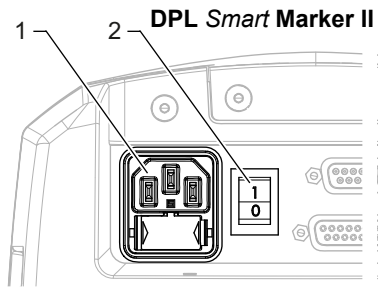
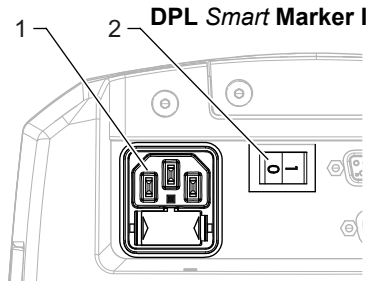

1. Ensure that the device power switch (2) is switched off.
2. Connect the supplied power cable to the power input module (1) of the laser device.
3. Connect the power cable to a safety contact socket.

Connection with the PC

1. The marking software must be installed.
2. Connect the USB interface of the laser marking device with the PC.

NOTICE

The laser control interface must be correspondingly wired.

5.5 Checking the Installation



RISK OF PROPERTY DAMAGE.
Perform the following tests to avoid material damage.

Please check the following points again before you start your laser system:

- Have the mechanical and electrical installations been performed correctly and completely?
- **Have you removed the protective cover from the focusing objective?**
- Is the focusing objective clean and dust-free?
- Do the environmental conditions meet the requirements (temperature, air humidity)?
- Are all the vents open?
- Is there an adequate fresh air supply to the laser device?
- Are you familiar with the essential laser protection regulations? Have all the laser safety measures been taken?
- Has the laser safety officer accepted the installation?

6 Operation

6.1 Operating and Display Elements

Control elements

The laser marking system just has a power switch (1) beside the power input module.

DPL Smart Marker I

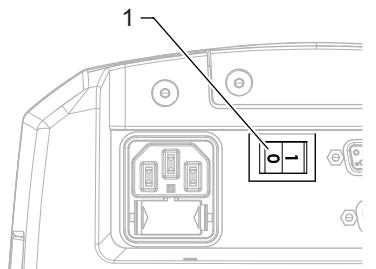

DPL Smart Marker II

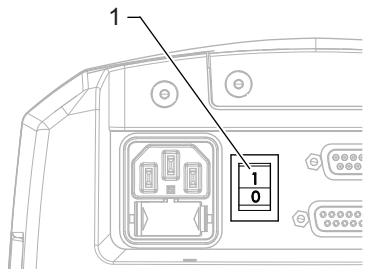

Operation

Multi function display

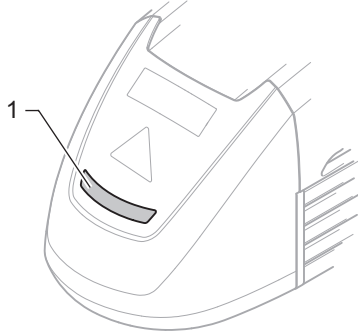

On the multi function display (1) the current working state of the laser marking device is to be seen.

Display	State	Meaning
Dark blue	Offline	Device switched on, Software not started or no communication
Dark-straw	Off	Communication exists, laser not activated
Dark green with pale yellow flash	On (not ready)	Laser activated, not ready for operation
Dark-green	On (ready)	Laser activated, ready for operation
Dark green with pale yellow light running down on both sides	Emission	Device operates
Light-yellow flashing	Warning	Warning, but the device continues to operate
Bright red flashing	Error	Fault, device deactivated, all power levels switched off electronically, see Fault Finding

6.2 Starting the Laser Marking Device

NOTICE

Keep to the switching sequence on each start.

1. Start the control PC.
2. Wait until the operating system has completely loaded.
3. Switch on the device power switch.

NOTICE

The interlock circuits must be open when switching on the device.

Follow the Windows installation instructions during the initial commissioning.
The main power pack supplies the supply voltages required.
The laser is not yet ready for operation.

4. Start the marking software.
The laser and scanner control, and the galvanometer are then initialized.

NOTICE

**The marking software starts in demo mode if it is not possible to communicate with the laser marking device.
The same happens if the software is started before the marking device.
You will find more detailed information on the software manual.**

6.3 Handling

The laser marking device is operated via the marking software.

All operating sequences are controlled from the control PC via the laser control interface. All the parameters are exclusively entered on the keyboard of the control computer.

NOTICE

Detailed information for using the marking software is contained in the software manual provided.

6.4 Fault Finding

6.4.1 General Faults

Problem/Fault	Possible cause	Elimination
Error message when loading the marking software	Marking software incorrectly installed	Reinstall the software.
No communication	USB cable not connected properly	Check whether the cable is plugged in correctly.
	No supply voltage	Check whether your laser is supplied with power.

Problem/Fault	Possible cause	Elimination
Laser will not start	USB cable not connected properly	Check whether the cable is plugged in correctly.
	Interlock circuits closed	Open the interlock circuits (must always be open upon system start-up).
	SD error	Start the marking software and check status / error reports in the status bar, respectively in the message window, to receive detailed information.
No laser beam	Shutter closed	Check whether all safety switches are locked. Check whether the shutter is opened in your marking job.
	Defocusing	Check the focus position by changing the distance between focusing objective and work piece.
	Incorrect laser parameters	Check your laser parameters, they may not be suitable for the work piece to be marked.
Laser power too low	Defocusing	Check the focus position by changing the distance between focusing objective and work piece.
	Incorrect laser parameters	Check your laser parameters, they may not be suitable for the work piece to be marked.
Laser does not pulse	Incorrect laser parameters	Check the laser parameter settings, the laser may be working in cw operation.

Problem/Fault	Possible cause	Elimination
Laser switches off automatically	Environmental conditions do not meet the specifications	Check the environmental conditions. Keep to the environmental conditions required.

NOTICE

Please contact our Technical Customer Service in the first instance if the fault cannot be eliminated as described above.

6.4.2 Specific Faults

The **Magic Mark** marking software monitors the laser device for possible faults and provides the user with status messages about the state of individual system components.

The messages are displayed in the system windows **Messages** on the monitor.

Status/Error	Trigger	Message	Evaluation per Software
Laser diode current deviation of +/- 10% of target	DiodeDrv	ERROR Overcurrent LD	Display + Cut Off
Overtemp_Diode-Driver	DiodeDrv	ERROR Overtemp LD-Driver	Display + Cut Off
5V Error, <4.5V	DiodeDrv	ERROR Undervoltage LD-Driver	Display + Cut Off
5V Error; <4.8V	DiodeDrv	WARNING Undervoltage LD-Driver	Display Warning
Break Laserdiode	DiodeDrv	ERROR Break LD	Display + Cut Off

Status/Error	Trigger	Message	Evaluation per Software
+/-15V Error, <13V >-13V	Head Control	ERROR 15V	Display
+/-15V Error, <13.5V >-13.5V	Head Control	WARNING 15V	Display Warning
Interlock circuits closed during the starting process	Laser Safety Device	SD WARNING interlock closed during startup	Display Warning
Interlock circuits open during current labelling	Laser Safety Device	SD WARNING interlock opened during operation	Display Warning
Shutter fault	Laser Safety Device	SD shutter ERROR	Display + Cut Off
Interlock fault	Laser Safety Device	SD interlock ERROR	Display + Cut Off
SD undervoltage	Laser Safety Device	SD ERROR internal undervoltage	Display + Cut Off
SD error	Laser Safety Device	SD internal ERROR	Display + Cut Off
24V Error, <22.0V	USB Control/LaserIFace	ERROR 24V	Display + Cut Off
24V Error, <22.5V	USB Control/LaserIFace	WARNING 24V	Display Warning
Overload I/O	USB Control/LaserIFace	ERROR Overload I/O	Display + Cut Off
Overtemp_Crystal	TempCtrl Crystal	ERROR Overtemp Crystal	Display + Cut Off
Break TE Crystal	TempCtrl Crystal	ERROR Break TE Crystal	Display + Cut Off
LoopStatus_LaserCrystal > Limit 1 (10 Min.)	TempCtrl Crystal	WARNING Temp Laser OOR1	Display
LoopStatus_LaserCrystal > Limit 2 (20 Min.)	TempCtrl Crystal	ERROR Temp Laser OOR2	Display + Cut Off
Break Sensor Crystal	TempCtrl Crystal	ERROR Break Sensor Crystal	Display + Cut Off
Break TE Diode	TempCtrl Diode	ERROR Break TE Diode	Display + Cut Off

Operation

Status/Error	Trigger	Message	Evaluation per Software
Break Sensor Diode	TempCtrl Diode	ERROR Break Sensor Diode	Display + Cut Off
LoopStatus_LaserDiode > Limit 1 (10 Min.)	TempCtrl Diode	WARNING Temp Diode OOR1	Display
LoopStatus_LaserDiode > Limit 2 (20 Min.)	TempCtrl Diode	ERROR Temp Diode OOR2	Display + Cut Off
Overtemp_Diode	TempCtrl Diode	ERROR Overtemp Diode	Display + Cut Off
RF-Internal Error	RF Drv	ERROR RF_Internal	Display + Cut Off
RF-REFLECTION	RF Drv	ERROR RF_SWR	Display + Cut Off
RF-Overtemp	RF Drv	ERROR RF_Temp	Display + Cut Off

An overview of the possible messages and their meaning can be found in the software manual.

7 Maintenance and Repair

7.1 Care

Perform the following care activities on the device at regular intervals.

- Clean the objective.
- Clean the ventilation slits of the covers.

 **WARNING**



DANGER OF INJURIES AND/OR RISK OF PROPERTY DAMAGE.
Ensure that the power plug has been pulled out before starting the cleaning tasks!

Cleaning the objective

A dirty objective reduces the transmission of the laser radiation. This leads to a reduction of the laser power on the work piece. The dirt can burn into the surface and damage the focusing objective. A protecting glass is therefore fixed in front of the objective by means of a threaded ring.

NOTICE

The warranty does not cover any damage caused by inadequate or improper cleaning.

Make a regular visual inspection of the focusing objective/protecting glass. Clean the protecting glass if any dirt is found (and the objective if necessary). Only cleansers which are authorised for high-quality optics may be used for this purpose:

- Never attempt to remove particles of dirt from the surface with compressed air.
- Use a suitable lens cleaning paper and ethanol of optical purity standard.
- Moisten one side of the cleaning paper. Do not touch the moist side under any circumstances.
- Draw the cleaning paper slowly over the protective glass/focusing objective. In so doing, draw the cloth in one direction only.
- Remove any ethanol residue with a dry lens cleaning paper if necessary.
- Repeat the procedure until the surface is completely clean. Use a new cleaning paper each time.

NOTICE

Suitable cleansers can be obtained from the manufacturer.

Cleaning the ventilation slits

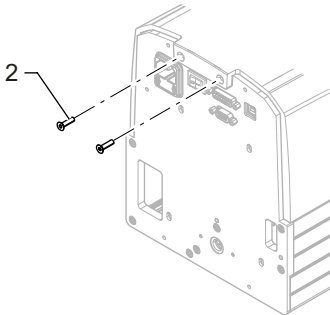
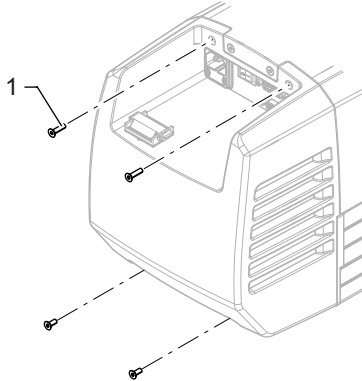

Cleaning the ventilation slits regularly is a prerequisite for faultless operation of the device. Clean the ventilation slits as follows:

1. Remove the 4 fixing screws (1) from the back of the laser device.
2. Pull the rear cover off the device.
3. Remove the two screws (2) of the center cover.
4. Remove the center cover.
5. Clean the ventilation slits in the covers with a dry or slightly damp cloth. Do not use any solvent for cleaning them.
6. Ensure that the covers are completely dry before reclosing the device.
7. Reassemble the covers in the reverse order.

NOTICE

**Slide the cover onto the device so its fits exactly.
Screw the fixing screws in hand tight.**

8. Check the electrical connections before bringing the device back into operation.

7.2 Maintenance, Repair

The laser device does not contain any parts which can be maintained or repaired by the user.

All maintenance and repair work must be performed exclusively by the manufacturer. The right to claim under warranty is lost as soon as third parties work on or modify the device.

The manufacturer has suitable test benches and routines to maintain your laser system optimally.



RISK OF PROPERTY DAMAGE.

During the warranty period, use the original packaging exclusively when dispatching the defective device.

Maintenance intervals

- Seek advice from the Customer Service of the manufacturer as to when your laser marking device should undergo maintenance. This depends on the specific use and duration.
- In order to maintain Performance Level e, the shutter assembly (swivel shutter) must be replaced no later than 14 years.

8 Scrap Disposal

ENVIRONMENT

Protect the environment!
For a fee, the customer will accept return of the laser device and dispose of it properly in a manner that is environmentally compatible.

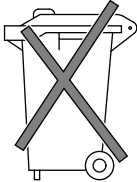

Environmentally sensible disposal of electrical and electronic equipment!

Electrical and electronic equipment contains valuable materials that should be supplied to recycling or recovery.

Please dispose of electrical and electronic equipment at qualified collecting points separate from municipal waste.

9 Detailed Advanced Information

9.1 DPL *Smart Marker I/II*, a highly integrated Marking System

Highly integrated means that the laser consists of only one component. The components

- optics,
- control electronics and
- thermoelectric air cooling

are combined in a single casing.

External power units, external laser diode pump modules and external water-air cooling units are now definitely things of the past.

The advantages are obvious:

- Integration into existing production lines has been made much easier as dimensions reduce the space requirement.
- Operational safety has been increased by eliminating electrical and fiber-optic connections.
- Complex water-air cooling units have been eliminated.
- A unique service concept has been set up. The complete unit is exchanged during maintenance work thus minimising down times and maintenance costs.

9.2 Design and Function

Preliminary remarks

The object of all laser marking is to produce high contrast markings on many different types of materials. Various marking processes can be selected by varying the pulse power density.

These include:

- laser engraving (erosion by vaporising the base material),
- vaporising the covering layers,

- colour changes produced by chemical reactions in the material.

The contrast is optimised by adapting the most important laser parameters to the material to be marked.

These include:

- laser beam quality,
- pulse length,
- cw output and peak pulse power density,
- pulse train frequency,
- vector velocity.

Basic terminology

The most important terms have been briefly stated and described in the following in order to aid understanding of the complex physical interactions involved in the generation of a laser beam.

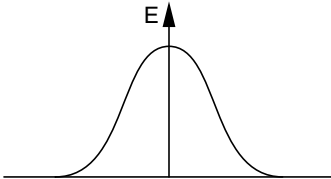

- **Laser:**
Light **A**mplification by **S**timulated **E**mission of **R**adiation.

- **TEM₀₀ - Mode, basic mode:**

The power distribution over the cross-section corresponds to a Gaussian function. The highest power occurs in the centre of the laser beam. The laser beam can be optimally focused.

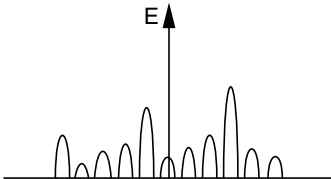

- **Multimode:**
The power distribution across the beam cross-section is random. Multimode laser beam sources cannot be well focused.

- **Mode diaphragm:**

A mode diaphragm corresponds to an apertured diaphragm, which cuts off the outer part of the laser radiation. The laser beam quality is increased, but the laser power is substantially reduced.
- **Beam parameter product SF:**

Product of the divergence angle of the laser beam and the beam diameter at the laser outlet.
The focusability of the laser beam improves as the SF falls.
- **Pulse length:**

The pulse length is another characteristic parameter of a Q-switched laser beam source. Depending upon the resonator structure, typical pulse lengths between 100 and 200 ns are achieved in the marking system's field of application.
The pulse length has a crucial influence on the peak pulse power which can be achieved on the surface of the material, and thus on the performance capability of the laser marker.
The **DPL Smart Marker I/II** achieves pulse lengths between ca. 20 and 50 ns. This enables the available cw laser power to be combined into extremely short pulses.
The chronological reduction of the pulse lengths enables the cw power to be reduced while the peak pulse power remains constant.
- **Pulse width dt:**

As a rule, the pulse width does not designate the length of a laser pulse but rather the opening time of the Q-switch. This gives the user the opportunity of treating the material with continuous laser radiation after a laser shot.
- **cw laser power:**

... This is the average continuous power output by the laser.
In the case of the **DPL Smart Marker I/II**, this is at least 4 W in the basic mode.
- **Pulse train frequency:**

The pulse train frequency is the number of laser pulses per second.

- **Vector velocity:**

Velocity with which the laser beam is deflected in the x-y direction.

The pulse width, cw laser power, pulse frequency and vector velocity are parameters which can be varied by the user. These parameters can be selected with the aid of the **Magic Mark** marking software according to the material and the desired marking effect.

For marking, the laser beam is positioned and focused on the work piece to be marked by the **FireSCAN** mirror deflection unit and a plane field lens.

The laser is controlled and monitored from the **Magic Mark** marking software.

9.2.1 Laser Beam Source

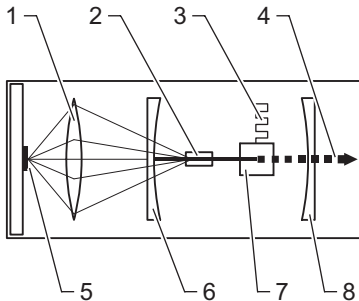

The laser beam source consists of an optical resonator for beam generation and amplification.

The resonator contains the excitation source consisting of laser diode (5) and convergent lens (1), two mirrors (6, 8), the active laser medium (2) and the Q-switch (7) arranged on an optical axis.

Detailed Advanced Information

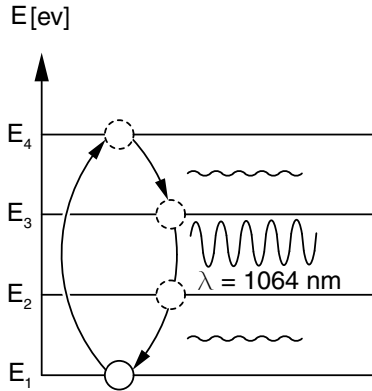

Ions or electrons in the active medium are brought to a higher energy level by the excitation source (pumping). The optical energy of the laser diodes is used for the excitation. An Nd:YAG (yttrium-aluminium-garnet) laser crystal which is doped with Nd³⁺ ions is used in the **DPL Smart Marker I/II**.

The energy level schema of the Nd³⁺ ions permits four possible energy levels. They are referred to as E1 to E4. Supplying the excitation energy raises the Nd³⁺ ion from the basic state E1 to the E4 state. The Nd³⁺ ion tries to return to the basic state E1. In so doing, it passes through the intermediate energy levels E3 and E2 into the basic state E1. The transition from level E3 into level E2 results in the spontaneous emission of light at a wavelength of 1064 nm. The transitions E4-E3 and E2-E1 are to the greatest extent without radiation.

9.2.2 Q-switch

The laser is equipped with an active Q-switch to amplify its power. This enables the continuous power of the laser to be amplified by several orders of magnitude.

The optical axis runs centrally through the Q-switch. If energy is supplied via the laser diode to the amplifier medium (Nd:YAG) and if the Q-switch is closed, all possible upper energy levels of the laser crystal are occupied. The laser process builds up like an avalanche if the Q-switch is now quickly opened. A laser pulse is generated, the power of which corresponds to the peak pulse power. The Q-switch is opened and closed by applying and interrupting a high-frequency voltage.

Continuous wave mode (cw)

If there is no high-frequency voltage at the Q-switch transducer, then the photons generated in the amplifier medium can pass unhindered through the Q-switch between the two laser mirrors.

Pulse operation

If a high-frequency voltage is applied to the Q-switch, this produces a very high loss which interrupts the stimulated emission.

High-energy laser pulses are released by switching the high frequency on and off at a pulse frequency.

This pulse frequency may be freely selected within the range of 1 kHz to 100 kHz. It is set via the marking software. The frequency is selected according to the work piece material. Practical working frequencies lie in the range of 1 kHz to 35 kHz.

9.2.3 Beam Deflection

For marking purposes, the laser beam has to be deflected onto the material within a working window which is freely selectable within certain limits.

The laser beam is deflected by a mirror system. The mirrors are arranged so that one mirror covers the x-axis and the other mirror the y-axis. This enables every point in the marking field to be reached. The deflection units used are galvanometer scanners.

9.2.4 Plane Field Objective

The size of the marking field is determined by the selection of a suitable objective.

Three objective sizes are offered for the **DPL Smart Marker I/II**:

F-THETA 100

Size of marking field: 60 mm x 60 mm

Spot diameter: 25 μm

F-THETA 163

Size of marking field: 110 mm x 110 mm

Spot diameter: 35 μm

F-THETA 254

Size of marking field: 180 mm x 180 mm

Spot diameter: 50 μm

After positioning the laser beam with the aid of the galvanometer scanning unit, it is focused on the work piece by a plane field objective.

Using this objective brings the entire marking level into focus.

Field correction

The special arrangement of the galvanometer mirror and the properties of the plane field objective distort the marking image.

A field correction therefore has to be made. This is done by pre-distorting the control signals for the galvanometer.

The distortion is system-specific and is therefore individually defined in your marking software.

9.2.5 Laser Control

Power supply

The operating voltages required for beam generation, the control system and the laser control interface are generated by a switched mode power supply. The input voltage range 100 - 240 V AC at 50/60 Hz which this can achieve enables the **DPL Smart Marker I/II** to be ready for immediate operation worldwide.

The low power consumption of < 400 W contributes to reducing the operating costs and protecting the environment.

Control system

The laser control (USB laser control) monitors and controls the entire laser process. Over a bus system it links the components:

- HF driver,
- laser diode driver,
- TE driver (laser diode),
- TE driver (resonator).

The laser control communicates with the controlling PC via the USB 2.0 interface.

All the information and commands required for the operation of the laser pass to the laser control in this manner. The data are evaluated and the appropriate responses produced in the device.

Interfaces

As the interface to external systems, the laser marking device has a laser control interface with active 24 V I/O signals.

9.2.6 Marking Software

All the laser's functions are controlled from the Windows-oriented **Magic Mark** marking software.

This includes both control functions such as laser power, frequency, velocity etc., and data transmission of the actual marking content.

The most important functions of the marking software are:

- Sequence control:
 - laser On/Off,
 - shutter On/Off,
 - subroutines,
 - communication with external devices,
 - handling,
 - links to host.
- Setting laser parameters:
 - power,
 - frequency.
- Setting galvanometer parameters:
 - delays,
 - speed.
- Character set selection:
 - fonts,
 - 1D barcodes, 2D barcodes (optional).
- Text formatting commands:
 - left and right justified, centred,
 - arc.
- Text content:

- serial numbers,
- fixed texts.
- Graphics:
The laser works vector-oriented.

The user should be aware of this when creating the marking jobs and when selecting the laser parameters.

The marking sequence may affect the total marking time. The user should avoid large jumps between the end and starting points of characters and/or graphic elements.

Please refer to your software manual for further information about the marking software.

9.3 Laser Beam Quality

The laser beam quality is a system constant of the laser beam source. It is a measure of the quality of the laser radiation.

The laser beam quality is a function of the design of the laser. The so-called beam parameter product SF is used as a measure of the beam quality.

The smaller the beam parameter product SF, the better the laser beam can be focused. The energy distribution over the cross-section of the laser beam is equally important for the beam quality.

A basic operating mode (TEM_{00}) of the laser in which the energy distribution corresponds to a Gaussian function is ideal.

In this case, the divergence of the laser is particularly small and the beam can be very well focused.

Multimode laser

Conventional laser beam sources emit a multimode beam. The energy is distributed randomly over the beam cross-section.

The beam quality of multimode lasers can only be increased by using aperture or mode diaphragms.

The diaphragms frequently reduce the power to 10% of the multimode power. In so doing,

Detailed Advanced Information

a TEM₀₀ mode is only approximately achieved.

The beam parameter product SF for the multimode laser is calculated according to the following formula:

$$SF_{TEMxx} = \Phi_{TEMxx} \cdot d_m$$

with SF Beam parameter product
 Φ Divergence
 d Beam diameter

DPL *Smart Marker I/II*

The diode-pumped **DPL *Smart Marker I/II*** laser system achieves direct generation of the basic mode by means of an ingenious resonator concept which eliminates the need for mode diaphragms. This guarantees the highest possible beam quality and the best focus. This provides the basic conditions for achieving the above average, high efficiency of the compact marker.

The beam parameter product SF for the **DPL *Smart Marker I/II*** is calculated according to the following formula:

$$SF_{TEM00} = \Phi_{TEM00} \cdot d_o = \lambda / \pi$$

with SF Beam parameter product
 Φ Divergence
 d Beam diameter
 λ Wave length 1064 nm

9.3.1 Pulse Power Density

The pulse power density provides a measure of the actual performance capability of a laser marker.

It is a function of the

- pulse frequency,
- pulse length and,
- beam radius

in the focus.

The following applies:

$$P_P = \frac{P_{cw}}{f \cdot dt}$$

with P_P pulse power
 P_{cw} continuous power
 f pulse train frequency
 dt pulse duration

and:

$$P_{Pd} = \frac{P_P}{r^2 \cdot \pi}$$

with P_{Pd} pulse power density
 r beam radius in the focus

9.4 Thermoelectric Air Cooling

9.4.1 Design

The design of the laser with the realisation of the highest peak pulse powers at low cw power enables the required pump output of the laser diode to be substantially reduced. This means that the heat generated and the dissipation power at the laser diode module are very low.

The dissipation power which is turned into heat in the **DPL Smart Marker I/II** is about 25 W. This means that this important characteristic is substantially lower in comparison to conventional diode-pumped laser marking systems.

For cooling and stabilising the temperature of the laser diode, the **DPL Smart Marker I/II** can therefore do without a water-air cooling system without impairing the performance capability of the cooling. Modern thermoelectric air cooling by means of Peltier elements is used instead.

Principle of operation of a Peltier element

Peltier, the French physicist, discovered in 1834 the effect that the temperature falls below the ambient temperature when current flows at the contact point of two touching metals. The efficiency of this effect has been increased enormously over the last few years by the use of modern semiconductor materials.

A Peltier element consists of an n- and a p-conducting semiconductor leg. These legs are linked by a copper bridge.

If a direct current flows through such an element, one side of the element cools and thus takes heat energy from the environment. This heat energy is then released again to the environment or a heat sink on the other side. The direction of the heat flow is reversed by changing the direction of the current.

A high cooling capacity is achieved by combining several Peltier elements in a Peltier block. The individual elements are connected electrically in series and thermally in parallel.

9.4.2 Cooler Dimensioning

Cooling the laser diode

The following boundary conditions apply to the dimensions of the cooler for the **DPL Smart Marker I/II**:

- minimum cold side temperature on the laser diode: $T_k = 20\text{ °C}$,
- maximum dissipation power of the laser diode: $P_v = 25\text{ W}$,
- maximum permissible ambient temperature: $T_u = 35\text{ °C}$.

A cooler unit which fulfils these requirements is integrated into the **DPL Smart Marker I/II**. A constant cold side temperature is maintained at the laser diode at an ambient temperature of $T_u = 35\text{ °C}$ with simultaneous full load operation of the laser ($P_v = 25\text{ W}$). This requires the use of high performance Peltier blocks. Two Peltier blocks, each with 127 Peltier elements are used thermally in parallel for cooling the laser diode.

The waste heat thus taken away from the laser diode is transferred to an aluminium cooler and released to the environmental air by means of a high performance fan.

The dimensioning of the aluminium cooler (surface, volume etc.), the selection of a suitable fan and the implementation of optimal heat transmissions play a key role here. The thermal resistance, characteristic of the cooler module are determined to $R_{th} < 0.1\text{ K/W}$.

Temperature stabilisation of the resonator

The stability of the laser in respect of power and beam quality is especially important for the reproducibility of inscriptions. The **DPL Smart Marker I/II** has therefore been equipped with temperature stabilisation of the active laser medium. This guarantees first class marking results even with very different power settings or even after the laser has been on stand-by for a long time. The temperature stabilisation of the laser crystal clearly reduced the formation of the so-called "thermal lens".

This temperature stabilisation is also realised via a thermoelectric module. As the resonator is very efficient, the module requires significantly less power. The waste heat is conveyed out by means of a fan.

9.5 The Materials Science of Laser Marking in Brief

The question of whether a material is suitable for laser marking can generally be answered with yes, provided that it adequately absorbs the processing wavelength, this is 1064 nm in the case of the **DPL Smart Marker I/II**.

Complex interactions take place between the laser beam and the work piece during the marking procedure.

The workability of a material depends upon the following material properties, among others:

- chemical composition,
- carbon content,
- spectral absorption,
- thermal conductivity,
- surface condition (dirt, structure, etc.).

The laser beam parameters also play a significant role.

These include:

- wave length,
- pulse frequency,
- pulse energy,
- peak pulse power,
- beam quality,
- focus diameter.

The large number of parameters show that the marking result depends upon several influencing factors.

The following section is intended to give the user an insight into the many possibilities for marking by means of a laser beam.

9.5.1 Pulse Overlapping

Targeted pulse overlapping is required in order to create a continuous line during the marking. The degree of overlapping substantially determines the marking result and it is selected according to the materials to be marked. The overlapping depends upon the vector velocity, the pulse train frequency and the focus diameter.

The following applies:

$$\ddot{u} = 1 - \frac{v}{f \cdot d}$$

with \ddot{u} overlapping
 f pulse train frequency
 v vector velocity
 d beam diameter at the focus

Example 1

Starting values:

$v = 100 \text{ mms}^{-1}$
 $f = 5500 \text{ Hz}$
 $d = 35 \mu\text{m}$

This gives:

$$\ddot{u} = 1 - \frac{0.1}{5500 \cdot 35 \cdot 10^{-6}} = 0.48$$



The overlapping of the laser pulses is thus ca. 50%.

Detailed Advanced Information

Example 2

Starting values:

$$v = 70 \text{ mms}^{-1}$$

$$f = 2000 \text{ Hz}$$

$$d = 35 \text{ } \mu\text{m}$$

This gives:

$$\ddot{u} = 1 - \frac{0.07}{2000 \cdot 35 \cdot 10^{-6}} = 0$$



There is no pulse overlapping in this example calculation, the pulses lie alongside each other.

9.5.2 Marking Methods

Heating



Low pulse power densities are used to heat the material surface without melting or vaporising it. The molecular structures on the surface are destroyed in this process, which can lead to the material changing colour.

If the temperatures are high enough, oxidation processes can cause a colour change and thus create contrasts.

Melting



The material melts at higher pulse power densities. After processing, the molten mass resolidifies and this may change the surface structure, e.g. swelling. A contrast is thus created at the treated places.

Vaporisation

If the peak pulse power density is increased still further, vaporisation processes will occur locally on the material and thus form holes and/or trenches (depending upon the overlapping parameters). The trenches thus formed throw shadows which creates a contrast. Heaping up generally occurs at the edges of the trenches in this form of marking.

Removal

The removal of surface coatings is a special form of laser engraving. Examples of this are colour removal and the removal of an anodising layer. In these cases, the lower-lying layers are exposed. Colour markings can be created in this way which have very good contrast.

9.5.3 Materials**Metals**

Metals can be laser marked by all three types of marking described.

Magnetism is a fundamentally different option to the marking results which can be achieved. Non-magnetic metals such as aluminium, copper and brass can be engraved by laser. The contrast arises solely from the shadow formation. A colour change is not possible with these metals.

Magnetic materials such as steel can of course also be engraved. Depending upon the carbon content, a colour reaction is possible, which is produced by an annealing colour. In practice, inscriptions on steel are often a mixture of laser engraving and annealing marking.

Surface contamination can affect the marking result. For example, an oil film leads to an improved annealing marking on steel.

The surface structure has an equally great effect on the marking result. The absorption on high reflecting surfaces (polished special steel) is very low. The possible processing speed is correspondingly reduced.

Detailed Advanced Information

Plastics

The diversity of plastics makes it difficult to provide a comprehensive overview of the marking behaviour of these materials. In principle, one differentiates between three types of plastics:

- thermoplastics,
- duroplastics,
- elastomer.

The plastics often contain other additives such as stabilisers, softeners, dyes etc.

Experience shows that ABS and certain thermoplasts can be marked very well and with high contrast. Whereas partially crystalline materials such as polyethylene (PE) and polypropylene (PP) can, as a rule, only be marked by the addition of laser-intensive additives.

The laser radiation produces a thermal reaction on the surface of the plastic material. This leads to vaporisation, removal of black pigments, frothing, bleaching or carbonisation of the plastics.

In the case of light-coloured plastics with good absorption, the carbonisation leads to dark markings as a result of the local temperature increase. Whereas in the case of dark plastics, the bleaching of carbon black or graphite ingredients can produce a high-contrast, light-coloured marking.

The addition of laser-sensitive pigments enables plastics which are otherwise difficult or impossible to mark to be treated so that a high contrast marking can be achieved.

Laser foils

If it is difficult or impossible to mark the materials directly, an alternative is to use foils which can be marked by a laser. These are self-adhesive foils which, as a rule, allow a high contrast marking by the removal of a covering layer. These labels can also be cut out by selecting suitable laser parameters.

The foils are available in many different colour combinations. Labels made in this way can only be removed from the workpiece with great difficulty and are usually destroyed in the process. These foils therefore offer high security against counterfeiting.

10 Appendix**10.1 Saturation Vapour Pressure as a Function of the Temperature**

t [°C]	p _d ' [mbar]
15	17.04
16	18.17
17	19.36
18	20.63
19	21.96
20	23.37
21	24.86
22	26.42
23	28.08
24	29.82
25	31.66

t [°C]	p _d ' [mbar]
26	33.60
27	35.64
28	37.79
29	40.04
30	42.42
31	44.91
32	47.54
33	50.29
34	53.18
35	56.22

To estimate the condensation temperature T_k , you need:

- T_u ambient temperature,
- T_c internal temperature of the laser marking device = 20 °C = const,
- φ air humidity.

Example calculation ($T_u = 25\text{ °C}$, $\varphi = 0.65\%$)

Proceed as follows:

1. Determine the saturation vapour pressure p'_d for $t = T_u$ in the table ($p'_d = 31.66\text{ mbar}$).
2. Calculate the vapour pressure $p_d = \varphi \cdot p'_d$ ($p_d = 0.65\% \times 31.66\text{ mbar} = 20.58\text{ mbar}$).
3. Determine the value $t = T_K$ associated with p_d in the table = 20.63 (nearest value) ($T_K = 18\text{ °C}$).

The following applies as a rule:

For $T_k < T_c$ or $T_k < 20\text{ °C}$

there is no risk of condensation on the laser components.

10.2 EC Declaration of Incorporation

This is to declare that the partly completed machine, based on its design and type of construction and in the version put on the market by us, conforms to the following fundamental requirements as defined in Directive 2006/42/EC on machinery. Anhang I, Artikel 1.1.2, 1.1.3, 1.1.5, 1.1.6, 1.1.1, 1.2.4.1, 1.3.2, 1.5.1, 1.5.2, 1.5.8, 1.6.3, 1.7 In addition, this partly completed machine conforms to the provisions set forth in Directive 2014/30/EC on electromagnetic compatibility and Directive 2011/65/EU on hazardous substances (RoHS) and the harmonized standard EN 50581:2012. In the event of any alteration to the partly completed machine or the intended purpose which has not been approved by us, this statement shall thereby be made invalid.

Device:
Type:

Marking laser



Applied EC directives and standards:
Directive 2006/42/EC on machinery
EN ISO 12100:2010
EN ISO 13857:2008
EN 349:1993+A1:2008

EN 60204-1:2006+A1:2009
EN ISO 13849-1:2015
EN 60825-1:2015-07

Representative for compiling technical documents:
Signed on behalf of the manufacturer by:

Mirko Wunderlich, Steinbrüchenstraße 14, 99248 Grammetal OT Nohra
Nohra, 2019-02-01

ACI Laser GmbH
Steinbrüchenstraße 14, 99428 Grammetal OT Nohra

Mirko Wunderlich
Geschäftsführer

Commissioning is prohibited until it has been determined that the machine which the device is to be installed complies with the provisions of the directive on machinery.

The manufacturer is obligated to send the specific documentation for the partially completed machine to the appropriate national authority in electronic form on request.

Declaration of Conformity according to the Electromagnetic Compatibility Directive 2014/30/EC on the following page.

10.3 EC Declaration of Conformity

We herewith declare that the machine described below, by virtue of its design and construction and moreover in the type brought onto the market by us, conforms to the relevant safety and health requirements of the applicable EU Directives.

In the event of any alteration to the device or the intended purpose which has not been approved by us, this statement shall thereby be made invalid.

Device:

Marking laser

Type:



Applied EC directives and standards:

Electromagnetic Compatibility Directive 2014/30/EC

Directive 2011/65/EU on Hazardous Substances (RoHS)

EN 55016-2-1:2014-12

EN 55016-2-3:2014-11

EN 61000-3-2:2015-03

EN 61000-3-3:2014-03

EN 50581:2012

Representative for compiling technical documents:

Mirko Wunderlich, Steinbrüchenstraße 14, 99248 Grammetal OT Nohra

Signed on behalf of the manufacturer by:

Nohra, 2019-02-01



ACI Laser GmbH

Steinbrüchenstraße 14, 99248 Grammetal OT Nohra

Mirko Wunderlich

Geschäftsführer

11 Index**A**

Ambient temperature	16
Assembly	31

B

Beam catcher	19
Beam deflection	21
Beam generation	21
Beam outlet	17, 21
Beam path	14
Beam source	25

C

Care	16
Cleaning	49
Cleaning the ventilation slits	51
Cleansers	50
Components	20
Condensation temperature	16
Connection values	24
Connection with the PC	39
Control elements	41
Customer service	12

D

Date of manufacturing	18
Defect	16
Demo mode	43
Device fuse	18
DIN EN 60825-1	13

DIN EN ISO 13849-1	13
E	
EC Declaration of Conformity	76
EC Declaration of Incorporation	75
Electrical installation	34
EMISSION	37
Emission light	37
Emission ready	38
Emission warning light	14
Emissions	14
Energy density	21
Extraction	15
F	
Fault finding	44
Fitting position	31
Focusing	32
Frequency range	18
F-Theta	32
Fuse	34
Fuse protection	24
G	
Galvanometer	19
H	
Humidity, relative	16
I	
Improper use	9
Initial start-up	15
Inputs	38

Installation	14
Electrical	34
Marking Software	33
Mechanical	30
Intended use	8
Interfaces	19, 24
Interlock circuit	35
Interlock connection	24, 34, 35
L	
Laser beam source	21
Laser class	24
Laser control	22
Laser control interface	24, 34
Laser crystal	21
Laser diode	21
Laser electronics	19, 22
Laser material	24
Laser power	24
Laser protection hood	7
Laser safety device	13, 22
Laser safety officer	8
Liability	8
M	
MagicMark	8
Maintenance	16, 49, 52
Maintenance intervals	52
Manufacturer	18
Manufacturer address	12
Marking field	21

Index

Marking job	38
Marking software	43
Installation	33
Mirror system	19
Multi function display	19, 42
O	
Objective	19
Operating company	7
Operating voltage	18
Operation	16
Optical bank	19
Outputs	38
P	
Performance level	24
Pilot laser	21, 24
Plane field objective	21
Power amplification	21
Power class	14
Power connection	39
Power consumption	18, 24
Power input module	19, 34, 39
Power switch	34, 41
Pulse frequency	21
Pulse repetition rate	24
Q	
Q-switch	19, 21
R	
READY	38

Repair	16, 52
Repair work	49
Resonator	19, 21
S	
Safety feature	22
Scan unit	19, 25
Scanning speed	25
Scope of delivery	28
Scrap disposal	53
SD	13
SD-READY	36
Series number	18
Shutter	14, 19, 21
Software	8
Spot diameter	21
Status messages	46
Storage conditions	25
Suitable height adjustment	32
Switching on the device	23
Switching sequence	43
T	
Technical data	24
Trainings	16
Transport	15
Type of objective	32
Type plate	18
U	
USB 2.0 interface	34

Index

V

Ventilation slits	51
Vents	40

W

Warning notices	17
Warranty	11, 52
Wave length	24
Wavelength	14, 21



Operating Instructions for **DPL Smart Marker I / DPL Smart Marker II**
Economy Diode

Article number: 21900004

Version: EN 02/2019-02

ACI Laser GmbH
Steinbrüchenstraße 14
D-99428 Grammetal OT Nohra

Phone: +49 3643 4152-0

Fax: +49 3643 4152-77

info@ACI-Laser.de

www.ACI-Laser.de