



Instruction Manual

colorCONTROL ACS7000

FCS-T-ACS1-30/0-50-1200

FCS-T-ACS1-45/0-38-1200

FCS-T-ACS2-R45/0-28-1200

FCS-T-ACS3-TR5-200-1200

FCS-T-ACS3-TR9-200-1200

FCS-T-ACS3-TT15-200-1200

MICRO-EPSILON Eltrotec GmbH
Manfred-Wörner-Straße 101

73037 Göppingen / Germany

Tel. +49 (0) 7161 / 98872-300

Fax +49 (0) 7161 / 98872-303

e-mail eltrotec@micro-epsilon.de

www.micro-epsilon.com

Certified acc. to DIN EN ISO 9001: 2008

Contents

1.	Safety	7
1.1	Symbols Used	7
1.2	Warnings	7
1.3	CE Compliance	7
1.4	Proper Use	8
1.5	Proper Environment	8
2.	Functional Principle, Technical Data	9
2.1	Measuring Principle	9
2.2	Structure of the System	9
2.3	Operating Modes	9
2.4	Technical Data	10
3.	Delivery	13
3.1	Unpacking	13
3.2	Storage	13
4.	Installation	14
4.1	Controller	14
4.2	Controller Elements	14
4.3	LEDs Controller	15
4.4	Electrical Connections Controller	15
4.4.1	General	15
4.4.2	Supply Voltage (Power)	15
4.4.3	Digital I/O	16
4.4.4	Color Switching Outputs	17
4.4.5	RS422	18
4.4.6	Ethernet, EtherCAT	18
4.4.7	Synchronization	19
4.4.8	Triggering	19
4.5	Sensor Cable, Optical Fiber	20
4.6	Attaching the Sensor	21
5.	Operation	24
5.1	Commissioning	24
5.2	Operation Using Web Pages	25
5.2.1	Requirements	25
5.2.2	Access via Ethernet	26
5.2.3	Measured Value Presentation with Web Pages	26
5.3	User Interface, Settings	27
5.3.1	Introduction	27
5.3.2	Login, Switching User Level	27
5.3.3	Sensor Fine Positioning, Positioning Target	28
5.3.4	Measuring Rate, Control Behavior	28
5.3.5	Light Source	30
5.3.6	Corrections, Referencing	30
5.3.7	Standard Observer, Illuminant, Color Difference	32
5.3.8	Color Management	33
5.3.8.1	Color Table	33
5.3.8.2	Create, Edit Teach Color	33
5.3.9	Digital interfaces	35
5.3.9.1	Parameters Overview	35
5.3.9.2	Selecting a Digital Interface	37
5.3.9.3	Ethernet	37
5.3.9.4	RS422 Interface	38
5.3.9.5	ColorOut	39
5.3.9.6	EtherCAT	39
5.3.10	Averaging, Error Handling, Statistics	40
5.3.10.1	Parameters Overview	40
5.3.10.2	Video Averaging	40
5.3.10.3	Color Value Averaging	40
5.3.10.4	Error Handling (Hold Last Value)	42
5.3.10.5	Statistics	42
5.3.11	Output Data Rate	42
5.3.12	Trigger Mode	43
5.3.13	Synchronization	44
5.3.14	Save / Load Setup	44
5.3.15	Export, Import all Setups	44
5.3.16	Manage Setups on PC	45
5.3.17	Extras	46
5.4	Detection	47
5.4.1	Location Chart	47
5.4.2	Temporal Display	49
5.4.3	Color Tolerance Parameters	50
5.5	Color Measurement	52
5.6	System	54
5.7	Spectrum	54
5.7.1	Comparison	54
5.7.2	Video Signal	55
5.7.3	CIE Diagram	56

5.8	Timing, Measurement Value Flux	57
5.9	Reset to Factory Settings	58
6.	Warranty	59
7.	Service, Repair	59
8.	Decommissioning, Disposal	59
	Appendix	
A 1	Optional Accessories.....	60
A 2	Factory Settings	61
A 3	ASCII Communication with Controller	62
A 3.1	General	62
A 3.2	Commands Overview	62
A 3.3	General Commands	65
A 3.3.1	General	65
A 3.3.1.1	Help	65
A 3.3.1.2	Controller Information	65
A 3.3.1.3	Reply Type.....	65
A 3.3.1.4	Parameter Overview	65
A 3.3.2	User Level.....	66
A 3.3.2.1	Changing the User Level	66
A 3.3.2.2	Changing to User Level	66
A 3.3.2.3	Querying the User Level	66
A 3.3.2.4	Defining the Standard User	66
A 3.3.2.5	Changing the Password	66
A 3.3.3	Sensor	67
A 3.3.3.1	Standard Observer and Standard Light Type.....	67
A 3.3.3.2	Control of the Light Source.....	67
A 3.3.3.3	Automatic Light Source Adjustment	67
A 3.3.3.4	Dark Reference.....	67
A 3.3.3.5	White Balance	68
A 3.3.4	Interfaces.....	69
A 3.3.4.1	Ethernet- / EtherCAT Mode.....	69
A 3.3.4.2	Ethernet IP Settings.....	69
A 3.3.4.3	Ethernet Measurement Transmission Settings	69
A 3.3.4.4	Setting RS422 Baud Rate	69
A 3.3.4.5	ColorOut Setting (Digital Out).....	69
A 3.3.4.6	Set Binary Format.....	70
A 3.3.4.7	Select a Color in the L*a*b*-Check Mode	70
A 3.3.5	Parameter Management, Load / Save Settings	70
A 3.3.5.1	Save Parameter	70
A 3.3.5.2	Load Parameter	70
A 3.3.5.3	Default Settings	70
A 3.4	Color Database.....	71
A 3.4.1	Color Table.....	71
A 3.4.1.1	Teaching New Color	71
A 3.4.1.2	Adjusting a Color Description	72
A 3.4.1.3	Threshold Values Based on the Mode of Calculation	72
A 3.4.1.4	Switching the Display of Color Space Data (XYZ or L*a*b*).....	73
A 3.4.1.5	Moving Color Entries in the Table	73
A 3.4.1.6	Resetting any Color Shifts.....	73
A 3.4.1.7	Deleting Color	73
A 3.5	Measurements	74
A 3.5.1	General	74
A 3.5.1.1	Type of Color Difference Calculation (Sphere, Cylinder, Box).....	74
A 3.5.1.2	Exposure Mode	74
A 3.5.1.3	Parameter Color Difference Calculation	74
A 3.5.1.4	Measuring Rate	74
A 3.5.2	Measurement Value Processing.....	74
A 3.5.2.1	Video Averaging	74
A 3.5.2.2	Averaging of Measurement Value (via Software).....	74
A 3.5.2.3	Setting the Statistics Calculation	75
A 3.5.2.4	Reset the Statistics Calculation.....	75
A 3.5.2.5	Error Processing	75
A 3.6	Data Output.....	75
A 3.6.1	Selection Digital Output.....	75
A 3.6.2	Measuring Mode	75
A 3.6.3	Select Measurement Values to be Output	76
A 3.6.3.1	Output Mode: Video/Spectrum	76
A 3.6.3.2	Output Mode: Color Measurement	76
A 3.6.3.3	Output Mode: Color Recognition.....	77
A 3.6.3.4	Output Hardware Status Values.....	77
A 3.6.3.5	Output of Statistics through RS422 and Ethernet	78
A 3.6.3.6	Signal Selection for Statistics.....	78

A 3.7	Hardware	78
A 3.7.1	Video Signal Request	78
A 3.7.2	Output Data Rate	78
A 3.7.3	Synchronization	78
A 3.7.4	Trigger Modes	79
	A 3.7.4.1 Trigger Type	79
	A 3.7.4.2 Trigger Level	79
	A 3.7.4.3 Number of Output Measurement Values	79
	A 3.7.4.4 Software Trigger Pulse	79
A 3.7.5	Booting the Controller	79
A 3.7.6	Keylock	79
A 3.8	Measured Value Format	80
A 3.8.1	Video Signal	80
A 3.8.2	Exposure Time / Frequency	81
A 3.8.3	Array Temperature	81
A 3.8.4	Light Source Temperature	81
A 3.8.5	Measurements of the Light Source	81
A 3.8.6	Measured Value Counter	81
A 3.8.7	Time Stamp	81
A 3.8.8	Color Measurement Data	81
A 3.8.9	Color Difference Values	82
A 3.8.10	Error Status	83
A 3.8.11	Statistics Values	83
A 3.9	Measurement Data Format	84
A 3.9.1	RS422 Interface	84
A 3.9.2	Transmitting Measurement Data to a Measurement Server via Ethernet	86
	A 3.9.2.1 Description Flags1	86
	A 3.9.2.2 Description Flags2	87
A 3.9.3	Ethernet Video Signal Transmission	88
A 3.10	Error Messages	89
A 3.11	Warnings	90
A 4	EtherCAT-Documentation	91
A 4.1	Preamble	91
A 4.1.1	Structure of EtherCAT®-Frames	91
A 4.1.2	EtherCAT® Services	91
A 4.1.3	Addressing and FMMUs	92
A 4.1.4	Sync Manager	92
A 4.1.5	EtherCAT State Machine	92
A 4.1.6	CANopen over EtherCAT	93
A 4.1.7	Process Data PDO Mapping	93
A 4.1.8	Service Data SDO Service	94
A 4.2	CoE – Object Directory	95
A 4.2.1	Communication Specific Standard Objects (CiA DS-301)	95
A 4.2.2	Manufacturer Specific Objects	98
A 4.3	Error Codes for SDO Services	115
A 4.4	Data Formats	115
A 4.5	Distributed Clock	116
	A 4.5.1 Introduction	116
	A 4.5.2 Synchronization	116
	A 4.5.3 Synchronization off	116
	A 4.5.4 Slave	116
	A 4.5.5 Apply Selected Settings	117
	A 4.5.6 Setting Regardless of TwinCat	117
A 4.6	Meaning of STATUS-LED in EtherCAT Operation	118
A 4.7	EtherCAT Configuration with the Beckhoff TwinCAT® Manager	119
A 5	Terminology	126
A 5.1	Standard Illuminant	126
A 5.2	Standard Observer	126

1. Safety

The handling of the system assumes knowledge of this operating manual.

1.1 Symbols Used

The following symbols are used in this operating manual.



Indicates a hazardous situation which, if not avoided, may result in minor or moderate injuries.



Indicates a situation which, if not avoided, may lead to property damage.



Indicates a user action.



Indicates a user tip.

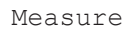

Indicates a hardware or a button/menu in the software.

1.2 Warnings



Connect the power supply and the display / output device in accordance with the safety regulations for electrical equipment.

- > Danger of injury
- > Damage to or destruction of the controller

The power supply must not exceed the specified limits.

- > Danger of injury
- > Damage to or destruction of the controller

Avoid shock and vibration to the sensor and controller.

- > Damage to or destruction of the sensor and controller

Never kink the optical fiber and do not bend in small radii ≤ 70 mm.

- > Damage to or destruction of the optical fiber; failure of the measuring instrument

Protect the optical fiber ends from dirt and contamination (use protective caps).

- > Faulty measurement
- > Failure of the measuring instrument

Only change a sensor when the light source is switched off.

- > Avoid risk of blinding.



1.3 CE Compliance

The following applies to the colorCONTROL ACS7000:

- EU directive 2004/108/EC
- EU directive 2011/65/EC, "RoHS" category 9

Products which carry the CE mark satisfy the requirements of the quoted EU directives and the European standards (EN) listed therein. The EC declaration of conformity is kept available according to EC regulation, article 10 by the authorities responsible at

MICRO-EPSILON Eltrotec GmbH
Manfred-Wörner-Straße 101
73037 Göppingen / Germany

The measuring system is designed for use in industry and satisfies the requirements..

1.4 Proper Use

- The colorCONTROL ACS7000 is designed for use in industrial and residential environments. It is used for
 - color measurement
 - color recognition (classification)
- The system may only be operated within the limits specified in the technical data, see Chap. 2.4.
- The measuring system should only be used in such a way that no persons are endangered or machines are damaged in the event of malfunction or total failure of the sensor. Additional precautions for safety and damage prevention must be taken for safety-related applications.

1.5 Proper Environment

- Protection class: IP 40 (Controller)
IP 64 (Sensor)
- Operating temperature: 0 ... 45 °C (+32 ... +113 °F)
- Storage temperature: -20 ... 70 °C (-4 ... +158 °F)
- Humidity: 5 - 95 % (non-condensing)
- Ambient pressure: Atmospheric pressure

2. Functional Principle, Technical Data

2.1 Measuring Principle

The sample is illuminated with homogeneous white LED light. The diffusely reflected light in a specified angle range is fed via a collecting lens and fiber optic to a spectrometer and analyzed. The diffuse spectral reflectivity of the sample is determined from the spectra of the sample and a white reference sample. The color coordinates required by the user with the respective boundary conditions such as color space, type of light, standard observer are calculated from the so determined reflection function in accordance with the methods specified in DIN 5033.

The advantage of this spectral method as compared with the three-range method is the greater accuracy of the color measurement. Thereby, the precise determination of the color values for various observation conditions (type of light, standard observer) with simultaneous coverage of the complete color space is possible.

2.2 Structure of the System

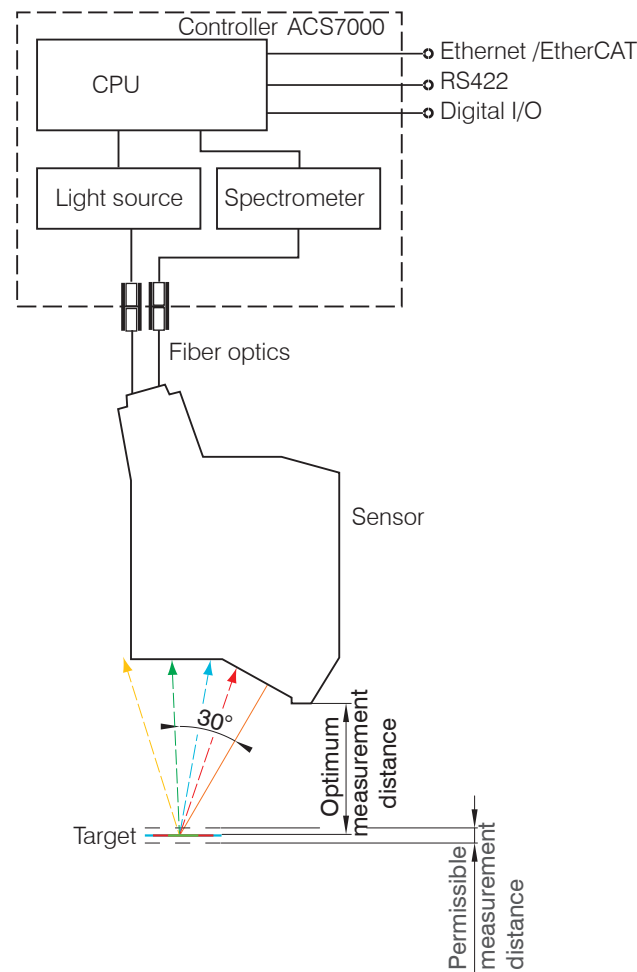

The colorCONTROL ACS7000 color measurement system is modularly designed. Different sensors, but not at the same time, can be coupled to the controller via a fiber optic connection.

Spectrometer and light source are integrated in the controller and each is connected to the sensor via its own fiber connection. The sensor is thus completely passive.

Fig. 1 Block diagram of the color measurement system colorCONTROL ACS7000

2.3 Operating Modes

- Measurement of the color values: The color values of the sample are determined and output for a specified set of measurement conditions (color space, type of light, standard observer).
- Measurement of the spectrum: The spectral reflection function is measured and output.
- Color recognition: The color values of the sample are determined and compared with the stored reference color values in the controller. If the measured color is within a specified tolerance range around one of these colors, this color is signalled as recognised.

2.4 Technical Data

Fiber-optic sensor FCS-T-	ACS1-30/0-50-1200	ACS1-45/0-38-1200
Measurement geometry (illumination / receiver)	30 °/0 °	45°/0°
Measuring spot diameter	9 mm	9 mm
Optimal measurement distance	50 mm	38 mm
Permissible measurement distance	±2 mm	±1
	of optimal measurement distance ($\Delta E < 1$)	
Distance tolerance	0.5 ΔE /mm	1 ΔE /mm
Tilt angular tolerance	<0.3 ΔE /°	<1.33 ΔE /°
Ambient light tolerance at max. LED-performance ¹⁾	<0.5 ΔE /1000 lux	<0.6 ΔE /1000 lux
Dimensions	85 x 120 x 40 mm	106 x 125 x 40 mm
Weight (sensor incl. optical fibre)	420 g	500 g
Length of the optical fiber/sensor cable (optical-fiber cable)	1.2 m (max 1.8 m)	1.2 m (max 1.8 m)
Bending radius sensor cable	70 mm	70 mm
Protection class	IP 64	IP 64
Operating temperature	-20 °C ... +70 °C	-20 °C ... +70 °C
Storage temperature	-20 °C ... +70 °C	-20 °C ... +70 °C
Shock resistance	DIN EN 60068-2-29; 15 g, 6 ms	
Vibration resistance	DIN EN 60068-2-6; 2 g / 10 Hz ... 500 Hz	

1) Measured at maximum illumination for reference tile (R = 61 %) light grey with warm white external LED light source

Fiber-optic sensor FCS-T-	ACS2-R45/0-28-1200
Article number	10824370
Measurement geometry (illumination/receiver)	45 ° circular/0 °
Measurement spot diameter	5 mm (optional 3 and 9 mm)
Optimal measurement distance	28 mm
Permissible measurement distance	±1 mm of optimal measurement distance ($\Delta E < 1$)
Distance tolerance	1 ΔE /mm
Tilt angular tolerance	<0.3 ΔE /°
Ambient light tolerance at max. LED-performance	<0.3 ΔE /1000 lux
Dimensions	Ø115 x 65mm
Weight (sensor incl. optical fibre)	822 g
Length of the optical fiber/sensor cable (optical-fiber cable)	1.2 m (max 1.8 m)
Bending radius sensor cable	70 mm
Protection class	IP 64
Operating temperature	-20 °C ... +70 °C
Storage temperature	-20 °C ... +70 °C
Shock resistance	DIN EN 60068-2-29; 15 g, 6 ms
Vibration resistance	DIN EN 60068-2-6; 2 g / 10 Hz ... 500 Hz

Fiber-optic sensor FCS-T-	ACS3-TR5-200-1200	ACS3-TR9-200-1200	ACS3-TT15-200-1200
Measurement geometry (illumination/receiver)	Receiver	Receiver	Transmitter
Measurement spot diameter	5 mm for <100 mm ¹⁾	9 mm for <200 mm ¹⁾	15 mm for 200 mm ⁵⁾
Optimal measurement distance	10 ... 100 mm ^{2) 3)}	10 ... 200 mm ^{2) 3)}	10 ... 200 mm
Permissible measurement distance	10 ... 200 mm ^{2) 3)}	10 ... 300 mm ^{2) 3)}	10 ... 300 mm
Distance tolerance ⁴⁾	<0.01 $\Delta E/mm$ ⁶⁾ <0.005 $\Delta E/mm$ ²⁾	<0.01 $\Delta E/mm$ ⁶⁾ <0.005 $\Delta E/mm$ ²⁾	-
Tilt angular tolerance ⁴⁾	<0.05 $\Delta E/^\circ$	<0.05 $\Delta E/^\circ$	-
Ambient light tolerance at max. LED-performance	<0.05 $\Delta E/1000lux$	<0.05 $\Delta E/1000lux$	-
Dimensions	Ø22 x 40 mm	Ø22 x 40 mm	Ø30 x 96 mm
Weight (sensor incl. optical fibre)	70 g	70 g	220 g
Length of the optical fiber/sensor cable (optical-fiber cable)	1.2 m (max. 30 m)	1.2 m (max. 30 m)	1.2 m (max. 1.8 m)
Bending radius sensor cable	70 mm	70 mm	70 mm
Protection class	IP 64	IP 64	IP 64
Operating temperature	-20 °C ... +70 °C		
Storage temperature	-20 °C ... +70 °C		
Shock resistance	DIN EN 60068-2-29; 15g, 6ms		
Vibration resistance	DIN EN 60068-2-6; 2g / 10Hz...500Hz		

1) Measurement spot diverges with growing distance between receiver and target

2) Valid in combination with ACS3-TT15-200 for the transmission measurement (transmitted light)

3) When measuring the transmission, the "optimal measurement distance" and the "permissible measurement distance" refer to the distance between transmitter and receiver.

The sample can be at any position within the light curtain between transmitter and receiver.

4) Tilt angular tolerance and distance tolerance were determined in transmission with different color glass filters (thickness 2.5 mm, refraction index 1.5).

When measuring the illumination (only receiver), these were determined with uniformly illuminated (Lambertian) diffuser by tilting the transmitter towards the receiver.

5) Illumination spot diameter

6) When using it as receiver sensor for illumination measurement

Controller, colorCONTROL ACS7000	
Spectral measuring range	390 - 780 nm
Measuring range reflectivity	0 - 200 %R
Output values	$L^*a^*b^*$, $L^*u^*v^*$, $L^*c^*h^*$, XYZ, ΔE , spectrum
Types of light	A, C, D65, D50, D75, E, F4, F7, F11, Off
Standard observer	2°, 10°
Distance models for color recognition	Sphere (ΔE), cylinder (ΔL^* , Δa^*b^*), box (ΔL^* , Δa^* , Δb^*), with individual tolerance parameters for every color taught
Color resolution	0.01 ΔE
Spectral resolution	5 nm
Measuring frequency	25 - 2,000 Hz (internal spectrum, signal averaging and data reduction are possible)
Temperature stability	<0.1 $\Delta E/^\circ\text{C}$
Light source	LED, 390 - 780 nm
Reproducibility of the measurements of a device ¹⁾	<0.03 (mean); <0.08 (max) ΔE
Housing dimensions	210 x 120x90 mm (W x H x D)
Weight	1.8 kg
Protection class	IP 40
Operating temperature	0 °C to 45 °C
Storage temperature	-20 °C to 70 °C
Inputs / Outputs:	Four color detection switching outputs (4 individual colors or 15 colors binary or $\{\Delta E, \Delta L^*, \Delta a^*, \Delta b^*\}$ for one color) 1 Switching output, synchronization 1 Switching input, synchronization 1 Switching output, measurement error
Interfaces	Ethernet/EtherCAT (DHCP-enabled) RS422 (USB via RS422 adapter is possible)
Connection for fiber optics	Illumination: 7mm ferrule with M18 cap (union) nut (analogous to MICRO-EPSILON Eltrotec Fasop system) Measuring: DIN fiber connector
Connection cables	To power supply: Art. No. 11234222 / to PLC: Art. No. 11234223 / to synchronization: Art. No. 11234091 / to PC: Art. No. 11294232 (Ethernet/EtherCAT); 11234224 or 11234230 (RS422)
Additional data processing	Internal calculation of spectral characteristics, color valence calculations, color space transformations, ΔE calculations, and tolerance settings of the upper and lower thresholds for the color values
Connection to software	Control and configuration via integrated Web server or via terminal with commands Visualization of spectral characteristics and temporal sequence of the color values and color differences
Power supply	24 VDC $\pm 15\%$, 1000 mA
Service life of the light source	>20,000 h when operated at 25 °C

1) Medium or maximum color distance DE of 1000 successive measurements of the color value (mean) of a light grey reference tile (R = 61%), measured with sensor FCS-T-ACS1-30/0-50-1200 at 200 Hz and maximum illumination brightness

3. Delivery

3.1 Unpacking

- 1 Controller colorCONTROL ACS7000
- 1 Controller acceptance report
- 1 CD with documents and auxiliary programs

Optional accessories:

- 1 FCS-T-ACS1-30/0-50-1200 fiber optical sensor, 9 mm measuring spot
- 1 Fiber optical sensor acceptance report
- 1 White standard 1.25 Fluorilon
- 1 CAB-RJ45-Eth; RJ45 patch cable Cat5e; 2 m
- 1 CAB-M9-4P-St-ge; power supply cable; 2 m
- 1 CAB-M9-8P-St-ge; synch. / error IO cable; 2 m
- 1 CAB-M9-7P-St-ge; ColorOut cable; 2 m
- 1 CAB-M9-5P-St-ge; RS422 cable; 2 m

The stated lengths are the standard lengths. Other cable lengths, all sensor heads and accessories can be found in the Appendix, see Chap. A 1.

- ➡ Check the delivery for completeness and any signs of transport damage immediately after unpacking. If the delivery is damaged or incomplete, contact the manufacturer or supplier immediately.

3.2 Storage

Storage temperature: -20 up to +70 °C

Humidity: 5 - 95 % (non-condensing)

4. Installation

4.1 Controller

Place the controller colorCONTROL ACS7000 on a level surface, or install it at a location of your choice (e.g. in a switch cabinet) using a DIN EN 60715 mounting rail (DIN rail TS35). The feet can be removed.

When using a DIN rail, an electrical connection (potential equalisation) is established between the controller case and the mounting rail in the switch cabinet.

➡ To remove the controller, push it upwards and pull it forwards.

> Inaccurate, erroneous measuring values

- Attach the controller so that no connections, operating and display elements are covered. Clearance of 3 cm next to the heat sink on the right side must be maintained.

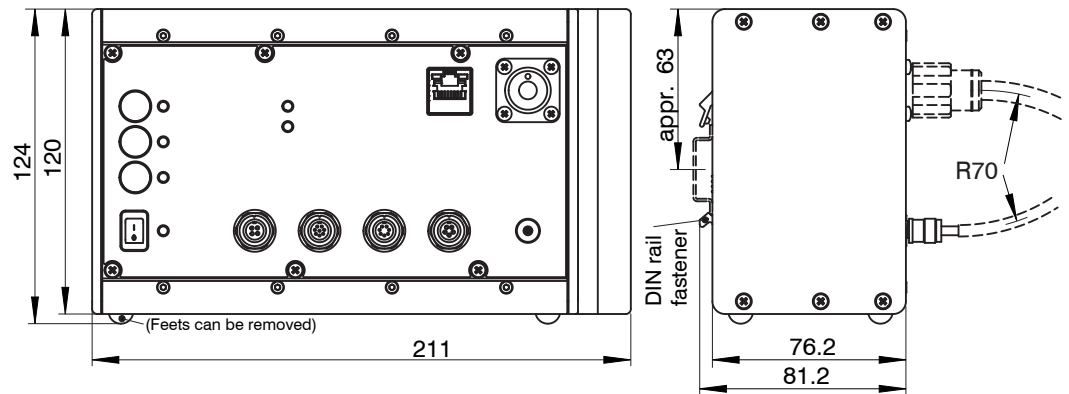

Fig. 2 Controller dimensional drawing, dimensions in mm

4.2 Controller Elements

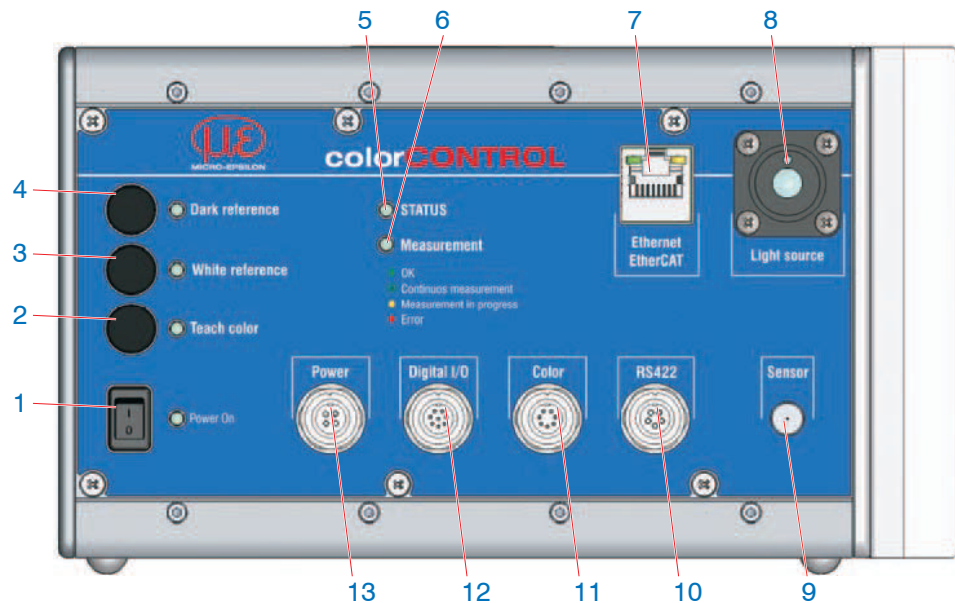

Fig. 3 Controller front view

1	On/off switch	8	Light source
2	Button, LED Teach color	9	Sensor connection
3	Button, LED White reference	10	RS422 connection
4	Button, LED Dark reference ¹	11	Color connection
5	LED Status	12	Digital I/O
6	LED Measurement	13	Power supply connection
7	Ethernet / EtherCAT		

Call up factory settings: Press and hold the buttons *Dark reference* and *Teach color* for appr. 10 s.

4.3 LEDs Controller

Power on	Green	Active operating voltage
Status (Ethernet)	Green	No errors, system ready for operation
	Red	Error
Status (EtherCAT)		If the EtherCAT interface is active, the meaning of the LED is in accordance with the EtherCAT guidelines.
Measurement	Off	No active data transmission
	Green	Active data output
	Red	Error
Dark reference, White reference, Teach color	Continuous green	Action has been performed successfully
	Flashing green	Action is running
	Continuous red	Action aborted with error
	Red	In the event of button press and active button lockout
	Orange	While changing the user level

Fig. 4 Meaning of the controller LEDs

4.4 Electrical Connections Controller

4.4.1 General

The cable shields are connected to the connector cases. The connector cases have contact with the controller case and the mounting rail.

All electrical connections must be made when the power is switched off.

The round connection sockets correspond to the Binder company Series 712 with screw coupling M9.

4.4.2 Supply Voltage (Power)

- 4-pin socket
- 24 V DC \pm 15%, $I_{max} < 1$ A
- not electrically isolated, protected against polarity reversal, GND is electrically connected to the GND wiring for switching outputs, synchronization and color signals.

➡ Use a shielded cable with a length less than 30 m. Micro-Epsilon recommends the use of the optionally available cable CAB-M9-4P-St-ge.

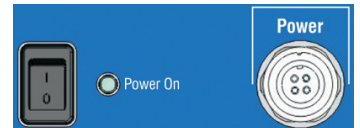

Fig. 5 Supply connections, switch and LED on the controller

Pin	Cable color CAB-M9-4P-St-ge	Function
1	White	n.c.
2	Brown	+ 24 VDC, \pm 15 %
3	Black	n.c.
4	Blue	GND (0V)

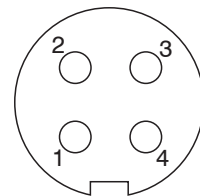

Fig. 6 4-pin male cable connector, solder side view

After switching on the supply voltage, the Power On LED lights.

Always use separate 24 V power supplies for measuring instruments in automation systems. Micro-Epsilon recommends the PS2020 power supply for DIN rail mounting in switch cabinets.

4.4.3 Digital I/O

The two push-pull Error switching outputs and synchronization output on the 8-pin Digital I/O socket are electrically connected to the power supply.

A jumper between the pins 7 and 8 determines the logic level for all signals at the Digital I/O and Color sockets.

- Pins 7 and 8 connected: HLL (high logic level)
- Pins 7 and 8 open: LLL (low logic level).

Error: Pins 1 and 2 (GND Error)

Sync. Out: Pins 3 and 4 (GND Sync. Out)

Sync. In / Trig.: Pins 5 and 6 (GND Sync. In)



The cable shield is connected to the case. Connect the cable shield at the evaluation unit.

Fig. 7 Digital I/O on the controller

All GND pins are interconnected, and they are connected to the operating voltage ground.

- ➡ Use a shielded cable. Cable length less than 30 m. Micro-Epsilon recommends the use of the optionally available cable CAB-M9-8P-St-ge.

Output level Error, Sync. Out (no load resistance) for a supply voltage of 24 VDC	LLL: Low 0.2 ... 0.8 V; High 4.5 ... 5 V
	HLL: Low 0.2 ... 0.8 V; High 23.5 ... 24 V
Output resistance	R_i appr.. 90 Ohm,
Load resistance, saturation voltage	LLL operation: $R_L \geq 100$ Ohm; $U_{sat-lo/hi}$ typ. 1.5 V
	HLL operation: $R_L \geq 2$ kOhm; $U_{sat-lo/hi}$ typ. 1.2 V

The saturation voltage $U_{sat-lo/hi}$ (with load resistance R_L) is measured between output and GND when output = Low, or between output and U_B when output = High.

Input level Sync. In / Trig.	LLL: Low 0.2 ... 0.8 V; High 2.0 ... 5 V
	HLL: Low 0 ... 5.5 V; High 10 ... 30 V

Pin	core color CAB-M9-8P-St-ge	Function
1	White	Error
2	Brown	GND Error
3	Green	Sync. Out
4	Yellow	GND Sync. Out
5	Grey	Sync. In / Trig.
6	Pink	GND Sync In / Trig.
7	Blue	LLL / HLL 4
8	Red	LLL/ HLL

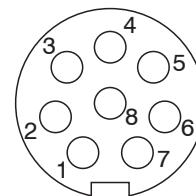

Fig. 8 8-pin male cable connector, solder side view

4.4.4 Color Switching Outputs

The four push-pull switching outputs on the 7-pin **Color** socket are electrically connected to the power supply.

A jumper between the pins 7 and 8 of the **Digital I/O** socket, see [Fig. 7](#), see [Fig. 8](#), determines the logic level of the switching outputs.

- Pins 7 and 8 connected: HLL (high logic level)
- Pins 7 and 8 open: LLL (low logic level).

Usage:

- for 4 individual colors or
- binary for 15 colors or
- for the tolerance parameters $\{\Delta E, \Delta L^*, \Delta a^*, \Delta b^*\}$



Fig. 9 Color switching outputs on the controller

The cable shield is connected to the case. Connect the cable shield at the evaluation unit. All GND pins are interconnected, and they are connected to the operating voltage ground.

➡ Use a shielded cable. Cable length less than 30 m. Micro-Epsilon recommends the use of the optionally available cable CAB-M9-7P-St-ge.

Output level Error, Sync. Out (no load resistance) for a supply voltage of 24 VDC	LLL: Low 0.2 ... 0.8 V; High 4.5 ... 5 V
	HLL: Low 0.2 ... 0.8 V; High 23.5 ... 24 V
Output resistance	R_i appr.. 90 Ohm,
Load resistance, saturation voltage	LLL operation: $R_L \geq 100$ Ohm; $U_{sat-lo/hi}$ typ. 1.5 V
	HLL operation: $R_L \geq 2$ kOhm; $U_{sat-lo/hi}$ typ. 1.2 V

The saturation voltage $U_{sat-lo/hi}$ (with load resistance R_L) is measured between output and GND when output = Low, or between output and U_B when output = High.

Pin	Core color CAB-M9-7P-St-ge	Function
1	White	Out 1
2	Brown	Out 2
3	Green	Out 3
4	Yellow	Out 4
5	Grey	GND
6	Pink	n. c.
7	Blue	n. c.

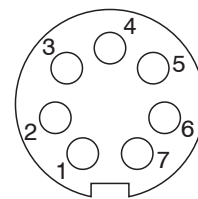

Fig. 10 7-pin male cable connector, solder side view, Series 712, Binder

The color switching outputs can be used in the program **Color Recognition** and in the program **Color Measurement** if **L*, a*, b* check** is selected as **ColorOut** output mode. The color switching outputs remain active while you change **L*, a*, b* check** using **ColorOut Output Mode** in the web interface in the tabs **Settings, Color Recognition** and **Color Measurement**.

The color switching outputs are active if you select **Web Graph, ColorOut** as primary interface used in the menu **Settings > Digital Interfaces > Interfaces and Data Selection**. With this setting, the color switching outputs are immediately after switching on the controller active without an additional interface to be enabled.

4.4.5 RS422

- Differential signals in accordance with EIA-422, electrically isolated from the supply voltage.
- Receiver Rx with a 120 ohm internal terminating resistor.
- ➡ Terminate the transmitter input on the evaluation unit (receiver) with 90 ... 120 ohm.
- ➡ Use a shielded twisted cable. Cable length less than 30 m.
- ➡ Connect the ground terminals.



Fig. 11 RS422 interface at the controller

Pin	Core color CAB-M9-5P-St-ge	Function
1	White	TX
2	Brown	/TX
3	Green	/RX
4	Yellow	RX
5	Grey	GND RS422

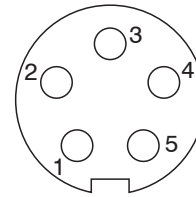

Fig. 12 5-pin male cable connector, solder side view

The wires must be crossed for the connection between controller and PC. The RS422 connections TX (1) and /TX (2) as well as RX (4) and /RX (3) must each be connected using a twisted pair of cores. This is guaranteed with the optional connection cable CAB-M9-5P-St-ge from the accessories.

4.4.6 Ethernet, EtherCAT

Potential isolated RJ 45 standard socket for connecting the controller

- to an Ethernet network (PC) or
- to the EtherCAT bus system (In port).
- ➡ Use a shielded Ethernet cable (Cat5E, patch cable, 2 m, included in the delivery, overall cable length less than 100 m) to connect controller and network.

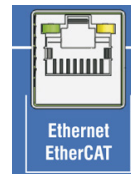

Fig. 13 RJ45 socket for Ethernet, EtherCAT

Both LEDs on the plug-in connector light to indicate that the connection was successful and its activity.

The measuring instrument can be configured using the Web interface or using ASCII commands (e.g. Telnet), or using EtherCAT objects.

4.4.7 Synchronization

Several color measurement systems can be synchronized in parallel using the synchronizing signal outputs and inputs on the Digital I/O built-in socket. The first system as Master synchronizes the subsequent system (Slave) etc.

- Connect the output Sync. Out of Controller 1 (Master) to the input Sync. In of Controller 2 (Slave) to synchronize two controllers with each other.

Controller 1 (Master)	Controller 2 (Slave)
Pin 3 Sync. Out	Pin 5 Sync. In
Pin 4 GND Sync. Out	Pin 6 GND Sync In

Fig. 14 Synchronization connections between two color measurement systems

- Use a shielded cable. Cable length less than 30 m. Connect the cable shield to 'Shield'.
- Ensure that the same level settings are used. Output and input levels are determined by the jumper between the pins 7 and 8 on the built-in Digital I/O socket, see Chap. 4.4.3.

4.4.8 Triggering

The color measurement system can also be triggered via the synchronization signal input on the built-in Digital I/O socket.

The trigger source (e.g. PLC, light barrier) must have the same level as the synchronization input on the built-in Digital I/O socket. The levels at the Digital I/O socket must be determined using a jumper at the pins 7 and 8, see Chap. 4.4.3.

The synchronization input is electrically connected to the power supply.

- Micro-Epsilon recommends the use of the optionally available cable CAB-M9-8P-Stage. Self-made cables must not exceed a length of 30 m.

Note that the measuring rate and output data rate are not automatically adjusted for the triggering. This should be set the same in the case of several controllers.

4.5 Sensor Cable, Optical Fiber

The sensor cable is permanently connected to the sensor. The sensor cable is divided into an optical strand for the illumination (light source) and the sensor signal.

- Illumination (light source): fiber optical connector with anti-twist protection
- Sensor signal: DIN connector with anti-twist protection

Both optical fiber connectors are each fixed using a screw coupling (knurled nut).

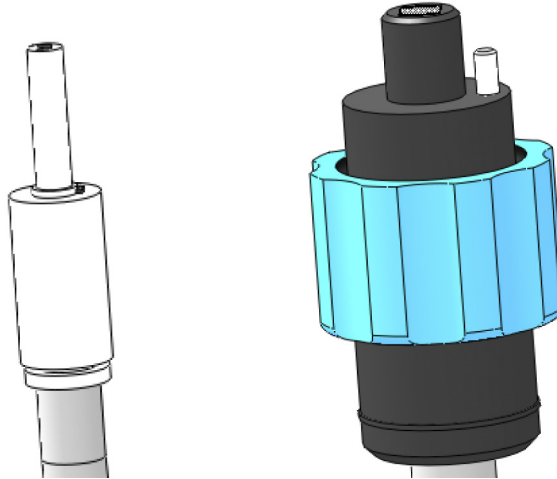

Fig. 15 Sensor connections (left signal, right light source)

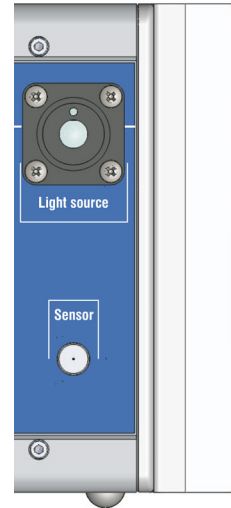

Fig. 16 Optical connections at the controller

Keep the end faces of the optical fibers free of dust; avoid any damage or soiling, e.g. by touching with fingers. This also applies for the plug connectors at the controller.

Clean soiled end faces with pure alcohol and a clean fluff-free microfiber cloth.

- Undercutting the minimum bending radius of 70 mm results in breakage of the optical fiber.

As the optical fiber consists of several fibers, a break results in a drop of the light intensity for illumination fibers and reduction of the measurement signal for the signal fibers. Fiber breakage results in loss of measurement sensitivity up to complete failure of the measurement signal.

NOTICE

Ensure that the end face of the optical fiber connector does not touch edges or surfaces. Reduced signal quality and/or failure of the measuring instrument.

Connecting the sensor cable to the controller

- Connect the light strand (thick strand, larger connector) to the controller.
- Align the coding pins on the fiber connectors upwards so that they engage in the slots on the controller and carefully tighten the union nut by hand.
- Connect the signal connector to the controller.

This sequence prevents twisting of the signal fibers.

- Only replace the sensor when the light source is switched off to avoid dazzling.

4.6 Attaching the Sensor

NOTICE

Mount the sensors only to the existing holes on a flat surface. Clamps of any kind are not permitted.

➡ Attach the sensors to the provided mounting holes. For the angle sensor ACS1 you need for example three cylinder-head screws M4x45.

Receiver optics must be positioned vertically (0 °) above the target.

The optimum distance between target and sensor is near the centre of the permissible measurement distance.

➡ Position the surface of the target at optimal working distance from the sensor, see Chap. 2.2. This value can be found in the calibration report of the sensor.

Alternatively, you can also use the Web interface (Video/Spectrum program area) to set the optimum working distance (= maximum amplitude), see Chap. 5.3.3.

• After replacement of a sensor, a new white balance and possibly adjustment of the light source brightness are required.

colorCONTROL Angle sensor ACS1

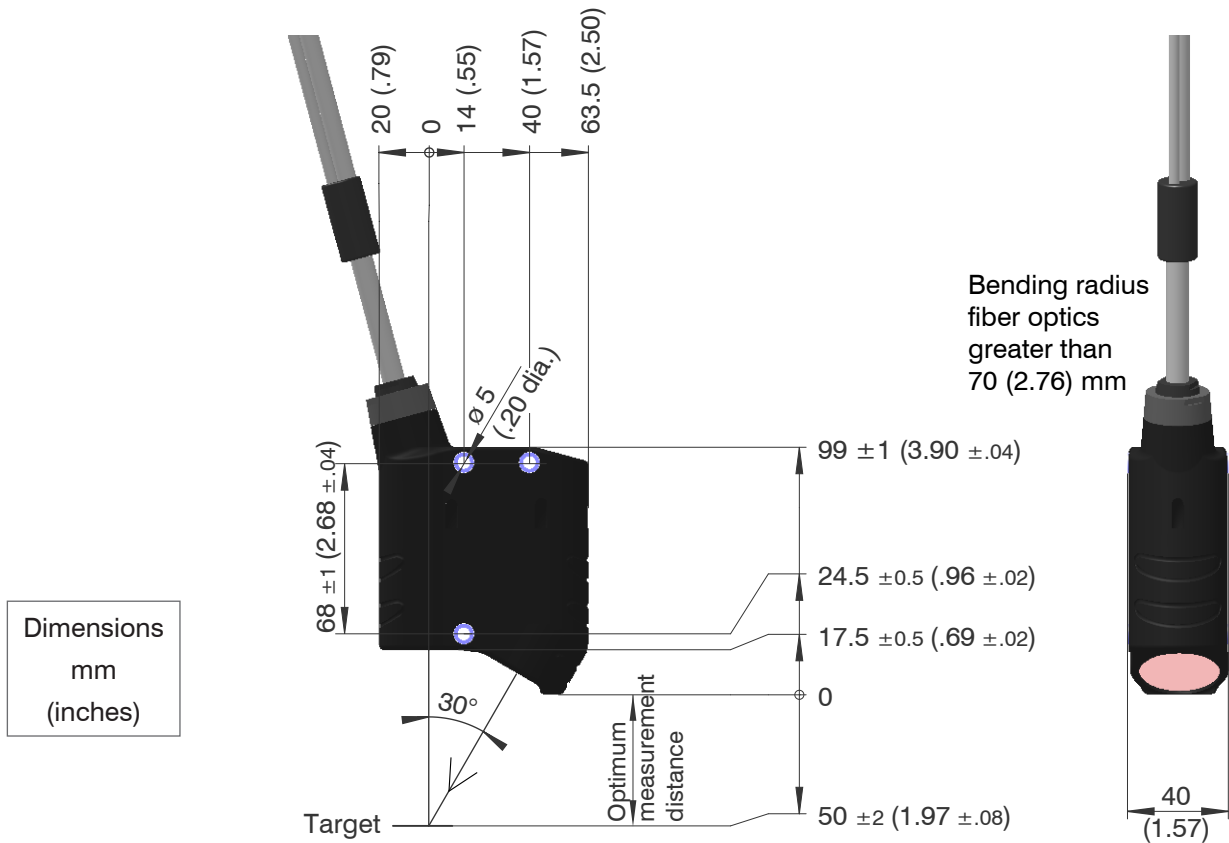

Fig. 17 FCS-TACS1-30/0-50-XXXX fiber optical angle sensor dimensional drawing

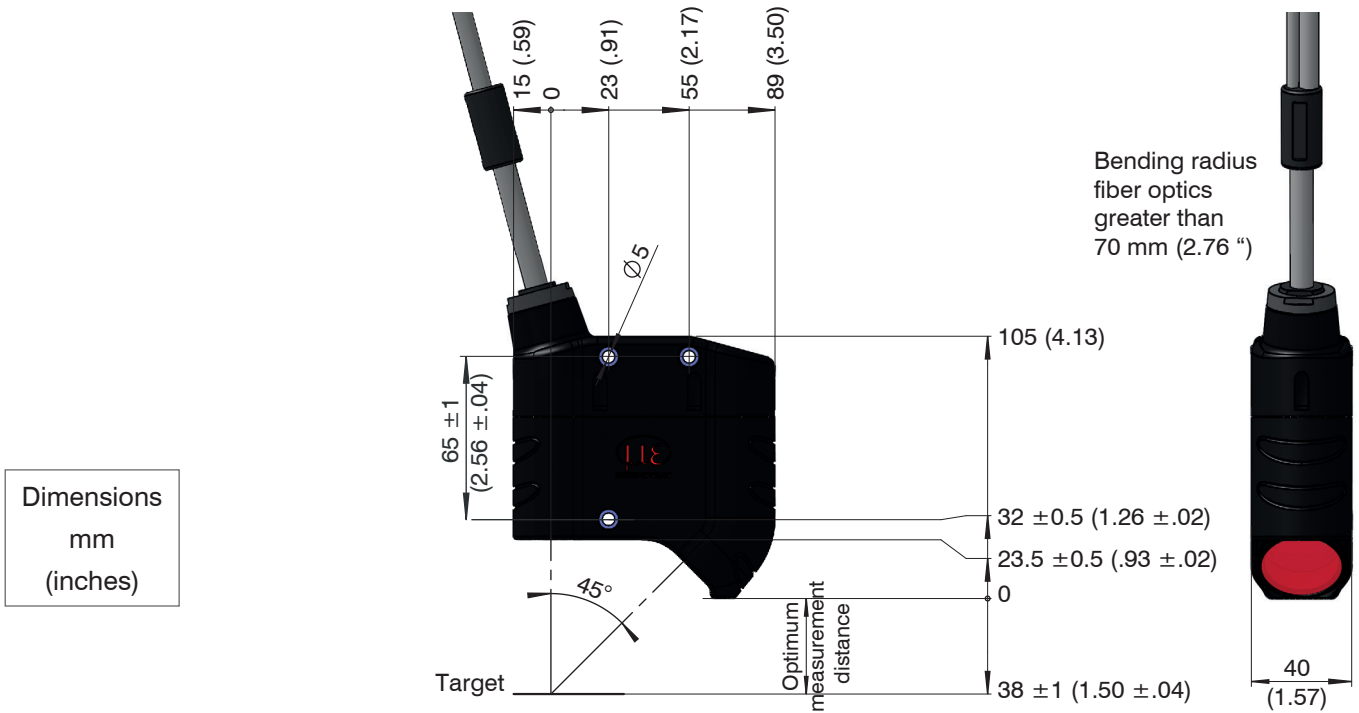

Fig. 18 FCS-X-ACS1-45/0-38-XXXX fiber optical angle sensor dimensional drawing

colorCONTROL Circular sensor ACS2

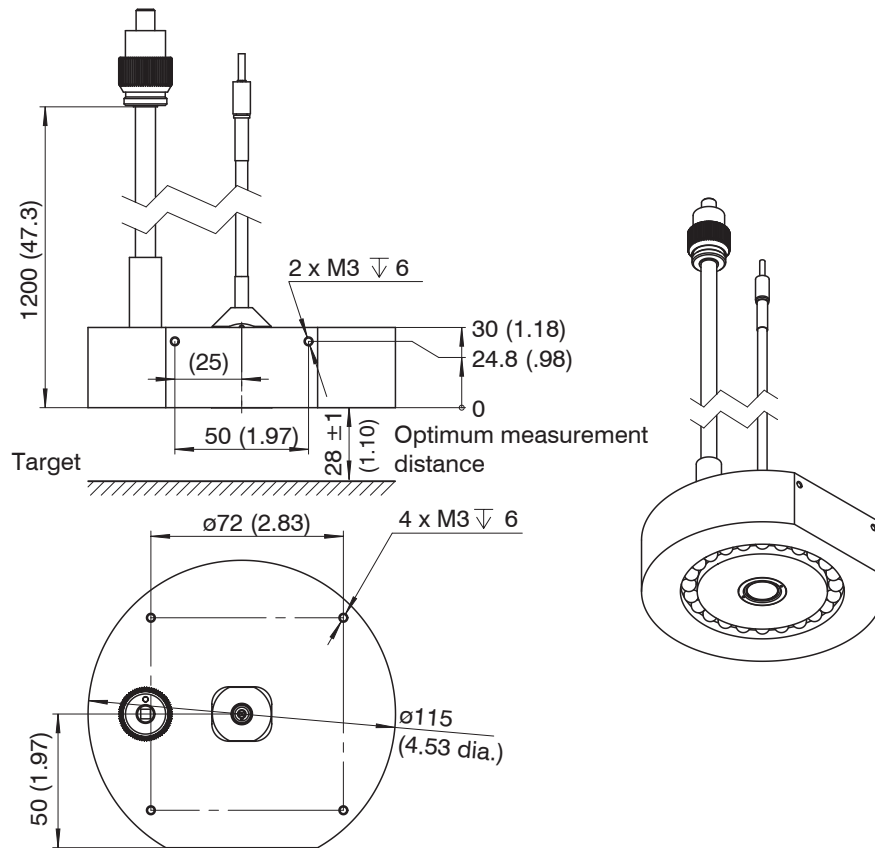

Fig. 19 FCS-X-ACS2-R45/0-28-XXXX circular sensor dimensional drawing

colorCONTROL Transmission sensor ACS3

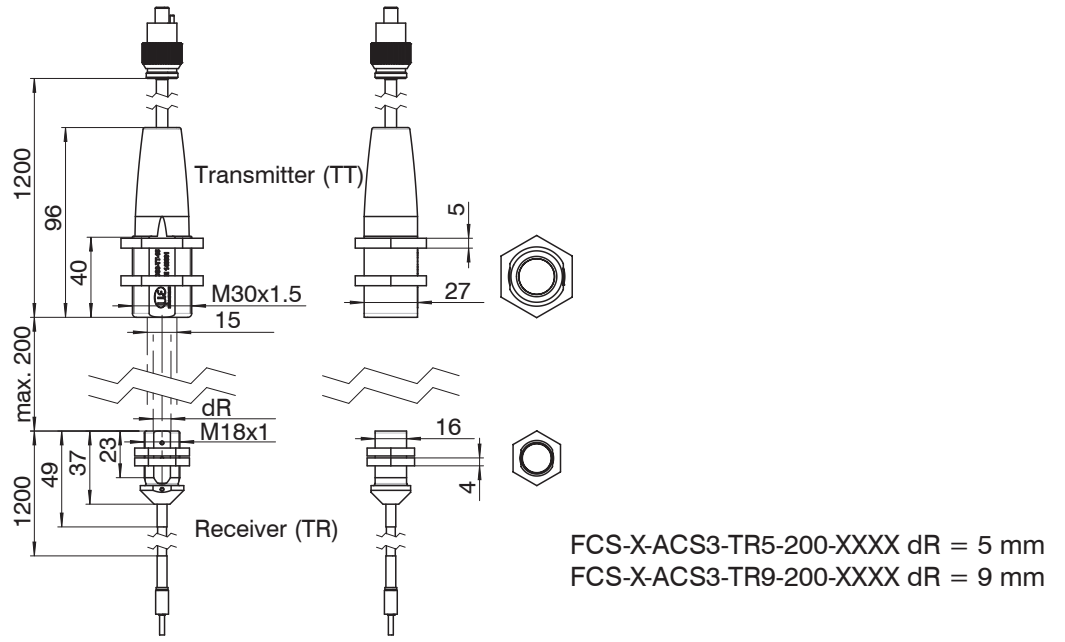

Fig. 20 FCS-X-ACS3-TRX-200-XXXX (Receiver), FCS-X-ACS3-TT15-200-XXXX (Transmitter) dimensional drawing

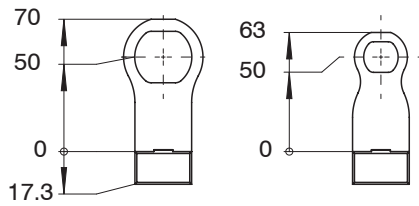

Fig. 21 FCS-ACS3, mounting adapter, standard

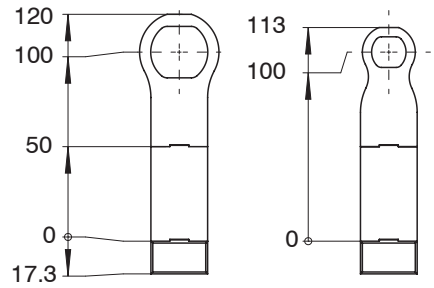

Fig. 22 FCS-ACS3, mounting adapter 50 mm

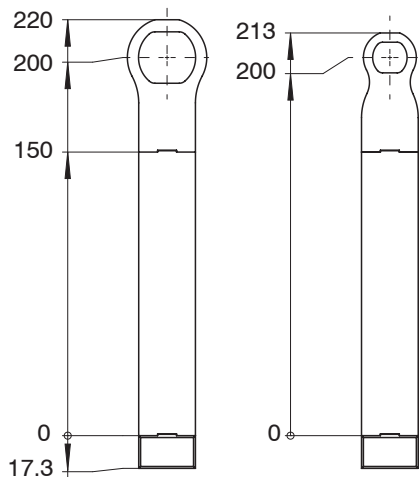

Fig. 23 FCS-ACS3, mounting adapter 150 mm

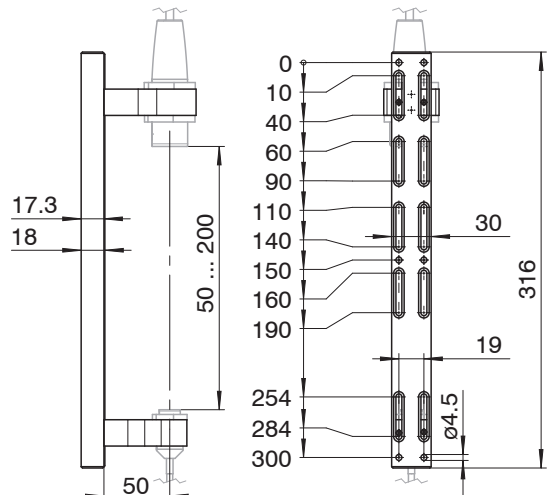
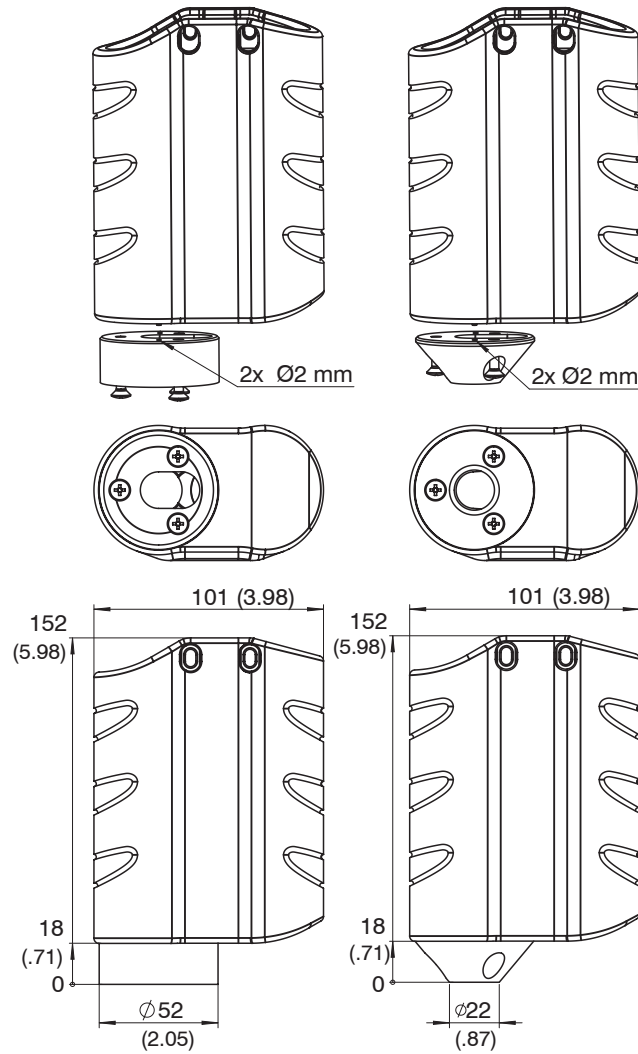

Fig. 24 FCS-ACS3-200, mounting rail

colorCONTROL Tactile Adapter



Dimensions
mm
(inches)

Fig. 25 FCS-X-ACS1-30/0-50-XXXX angle sensor adapter

5. Operation

5.1 Commissioning

- Connect the sensor and the controller using the optical fiber, see Chap. 4.5.
- Connect the controller to a power supply, see Chap. 4.4.2.
- Connect the controller to the following display or monitoring units.
- Switch on the controller.

After the controller has been switched on, the **Power On LED** lights.

The initialization is performed after switching on the controller. The system is ready for making measurements when the **STATUS LED** is lit green without flashing.

i To ensure precise measurements, let the measuring system warm up for about 40 minutes.

5.2 Operation Using Web Pages

Dynamic web pages are generated in the controller which contain the current settings of the controller and the peripherals. Operation is only possible while there is an Ethernet connection to the controller.

5.2.1 Requirements

You need a web browser (e.g. Mozilla Firefox ≥3 or Internet Explorer 7) on a PC with a network connection. The controller is set to a direct connection to support easy initial commissioning of the controller. If you have configured your browser so that it accesses the Internet via a proxy server, please add the IP address of the controller in the browser settings to the list of addresses which should not be routed via the proxy server. The MAC address of the measuring instrument can be found on the rating plate of the controller and on the acceptance report.

“Java” and “Javascript” must be enabled and up-to-date in the browser so that measurement results can be displayed graphically. The PC needs Java (Version 6, from update 12). Source: www.java.com > “JRE6 Update 12”.

Direct connection with PC, controller with static IP address (factory setting)		Network
PC with static IP	PC with DHCP	Controller with dynamic IP address, PC with DHCP
<p>➔ Connect the controller to a PC using a direct Ethernet connection (LAN). Use a LAN cable with RJ-45 connectors for this.</p>		<p>➔ Connect the controller to a switch using a direct Ethernet connection (LAN). Use a LAN cable with RJ-45 connectors for this.</p>
<p>➔ Start the program <code>SensorFinder.exe</code>. This can be found on the CD included in the delivery.</p> <p>➔ Click on the <code>Find sensors</code> button. Select the required controller from the list. To change address settings, click on the <code>Change IP-Address</code> button.</p> <ul style="list-style-type: none"> • Address type: static IP-Address • IP address: 169.254.168.150¹ • Subnet mask: 255.255.0.0 <p>➔ Click on the <code>Change</code> button to transmit the changes to the controller.</p> <p>➔ Click on the <code>Start Browser</code> button to connect the controller to your standard browser.</p> <p>1) It is assumed that the PC LAN connection uses the following IP address: 169.254.168.1.</p>	<p>Wait until Windows has established a network connection (connection with limited connectivity).</p> <p>➔ Start the program <code>SensorFinder.exe</code>. This can be found on the CD included in the delivery.</p> <p>➔ Click on the <code>Find sensors</code> button. Select the required controller from the list.</p> <p>➔ Click on the <code>Start Browser</code> button to connect the controller to your standard browser.</p>	<p>➔ Enter the controller in DHCP / notify the sensor to your IT Department.</p> <p>The controller is allocated an IP address by your DHCP server. You can query this IP address with a program called <code>SensorFinder.exe</code></p> <p>➔ Start the program <code>SensorFinder.exe</code>. This can be found on the CD included in the delivery.</p> <p>➔ Click on the <code>Find sensors</code> button. Select the required controller from the list.</p> <p>➔ Click on the <code>Start Browser</code> button to connect the controller to your standard browser.</p> <p>OR: If DHCP is used and the DHCP server is coupled to the DNS server, access to the controller via a host name with the structure “ACS7000_SN<serial number>” is possible.</p> <p>➔ Start a web browser on your PC. To reach an ACS7000 with the serial number “01234567”, enter “ACS7000_SN01234567” in the address bar of the web browser.</p>
<p>Interactive web pages for programming the controller and peripherals are now shown in the web browser.</p>		

5.2.2 Access via Ethernet

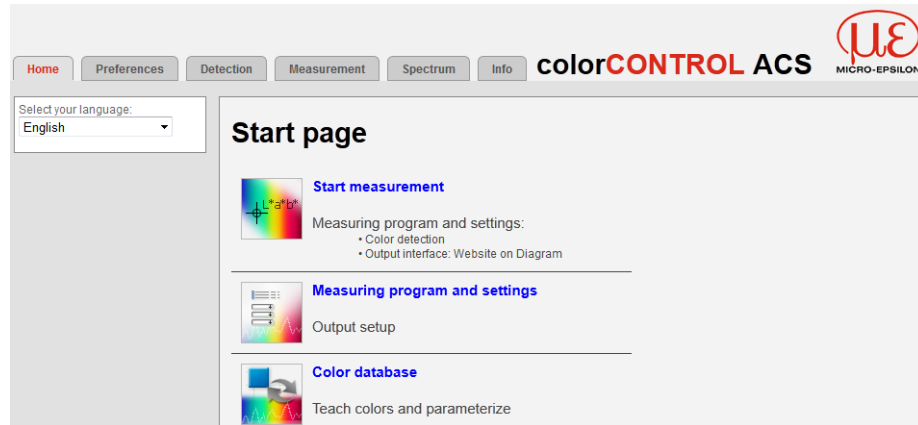

Fig. 26 First interactive web page after calling the IP address

Use the upper navigation bar to access additional features (settings, spectrum etc.).

All settings in the web page are implemented immediately in the controller after pressing the **Apply** button.

Parallel operation with web browser and ASCII commands is possible; the last setting applies. Do not forget to save.

The appearance of the web pages can change depending on the functions and the peripherals. Most pages contain parameter descriptions and tips for configuration of the controller.

5.2.3 Measured Value Presentation with Web Pages

➡ Start the measured value display (tab **Color Recognition**, **Color Measurement**) in the horizontal navigation bar.

Diagram control and display are loaded in the browser as a Java program which continues to run independently from the controller (which also continues to operate independently).

! By letting the diagram display run in a separate tab or browser window, you do not have to restart the display every time.

The diagrams start automatically with call of the function.

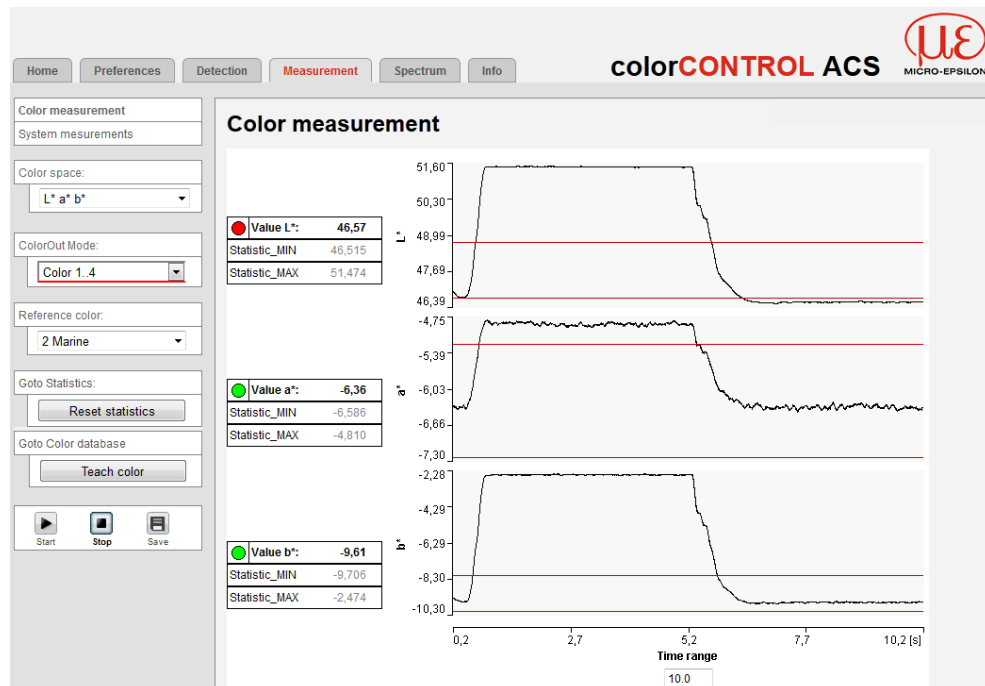

Fig. 27 Display of the measurement results

5.3 User Interface, Settings

5.3.1 Introduction

The system can be programmed in two different ways at the same time:

- using web browser via the controller web interface
- using ASCII commands and terminal program via RS422 or Ethernet (Telnet).

i When programming has been completed, all settings must be permanently stored in a set of parameters to ensure that these settings will be available when the controller is switched on the next time.

5.3.2 Login, Switching User Level

Assigning passwords prevents unauthorized changes to controller settings. The password protection is not activated in the delivery condition. The sensor operates at the `Professional` user level. After the controller has been configured, you should enable password protection. The default password for the Professional level is "000".

i A software update will not change the default password or a user-defined password. The Professional password is independent from Setup and is thus not loaded or stored with Setup.

An active diagram on the web pages may lead to faulty presentations, if for e. g. the measurement mode or the distance model is changed via RS422 or Telnet.

The following functions are accessible for the user:

User level	User	Professional
Password required	no	yes
View settings, change language	yes	yes
Change settings, change password	no	yes
Color recognition, color measurement, spectrum programs	yes	yes
Scale graphs	yes	yes
Restore factory settings	no	yes

Fig. 28 Permissions within the user hierarchy

Login

Currently, you are logged in as **User** .
 Password for login as a Professional:

Enter the default password "000" or a user-defined password in the Password field and click on Login to confirm.

Fig. 29 Changing to Professional level

Click on the Logout button to change to the User mode.

In Professional mode, you can use user management to assign a user-defined password.

Changing the password	Value	All passwords are case-sensitive. Numbers are allowed, but special characters are not permitted.
User level when switching on	User / Professional	Defines the user level that is enabled when the sensor starts the next time. MICRO-EPSILON recommends selecting Professional level here.

i When the Professional restores the factory settings (Settings menu > Tools > Factory Settings), the Professional level password is reset to "000".

Fields with a grey background require a selection.

Dark bordered fields require the specification of a value.

5.3.3 Sensor Fine Positioning, Positioning Target

- ➡ Change to the color measurement program and select XYZ as color space. Place a bright target as close as possible to the centre of the measuring range.

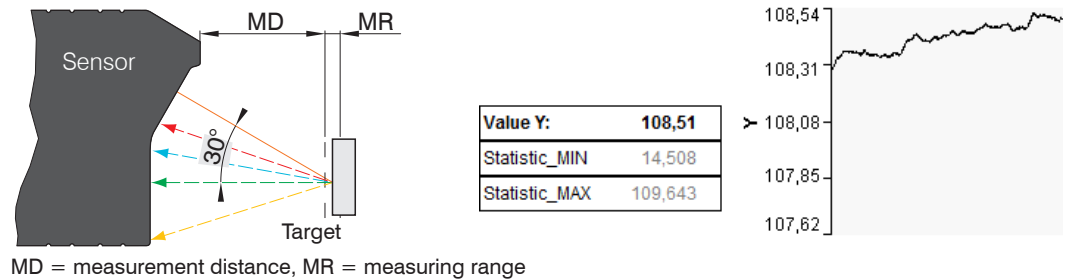

MD = measurement distance, MR = measuring range

- ➡ Undo the sensor fastening and move the sensor until the signal \bar{Y} is at its maximum. Fasten the sensor.

5.3.4 Measuring Rate, Control Behavior

Control behavior	Automatic mode / Measurement mode / Manual mode		
Measuring frequency	Manual measuring frequency	Value	25 ... 2000 Hz
	250 Hz / 500 Hz / 1 kHz / 2 kHz		

Automatic mode. In automatic mode (factory setting), the measuring rate and the exposure time are changed by the controller so that each target is measured with the optimum measuring rate, i.e. smallest possible measuring rate and longest practical exposure time. This corresponds to a maximum control range.

This mode is useful to minimise the fluctuations of the measured values (noise) and the measuring rate only plays a subordinate role. Depending on the amount of light, the exposure time is freely regulated between 0.5 ms (2 kHz) and 50 ms (20 Hz).

Measurement mode. In the measurement mode, the required measuring rate is frozen and only the exposure time is still regulated. The process has a smaller control range than automatic mode, but is faster. Differently reflecting targets can also be measured using the same measuring rate here. This mode enables a minimum measuring rate to be defined. The exposure time is only regulated up to this limit.

Manual mode. No regulation takes place in the manual mode. The system measures using a constant measuring rate / exposure time defined by the user. This mode makes sense for fast changes due to targets with identical surfaces moving in and out or for highly dynamic movements (no overshoots).

Notes for selection of the control behavior

In the automatic regulation variants (automatic mode, measurement mode), failure of individual measurements can occur in the case of rapid brightness changes of the target. As the regulation of the exposure time has a certain delay, one to two individual measurements, unfavourable measurements can occur in this case due to overexposure of the detector.

Manual mode provides a valid result for every measurement even in these cases. Manual mode requires that a measuring rate is selected which does not cause any overexposure of the detector. This can be checked by evaluation of the spectrum of the white reference after performing a white balance. In the case of a sensibly selected measuring rate, a straight line should be visible (reflectivity appr. 100 for all wavelengths). In the case of overexposure, a clear drop in the middle of the spectral range is visible. For the measurement of fluorescent targets where the reflectivity can be greater than 100, an appropriate safety factor (1.2 to 2) should be planned.

Notes for the determination of a suitable measuring rate

- 1 Applies for the Manual Mode, Measurement Mode control behavior and requires the Professional user level.

The optimum measuring rate depends on the specified light source brightness and on the sensor used.

- ➔ Position a white target inside the measuring range.
- ➔ Change to the Spectrum program and select Array Signal.
- ➔ Select the Automatic Mode exposure mode.

The optimum measuring rate is indicated in the array signal.

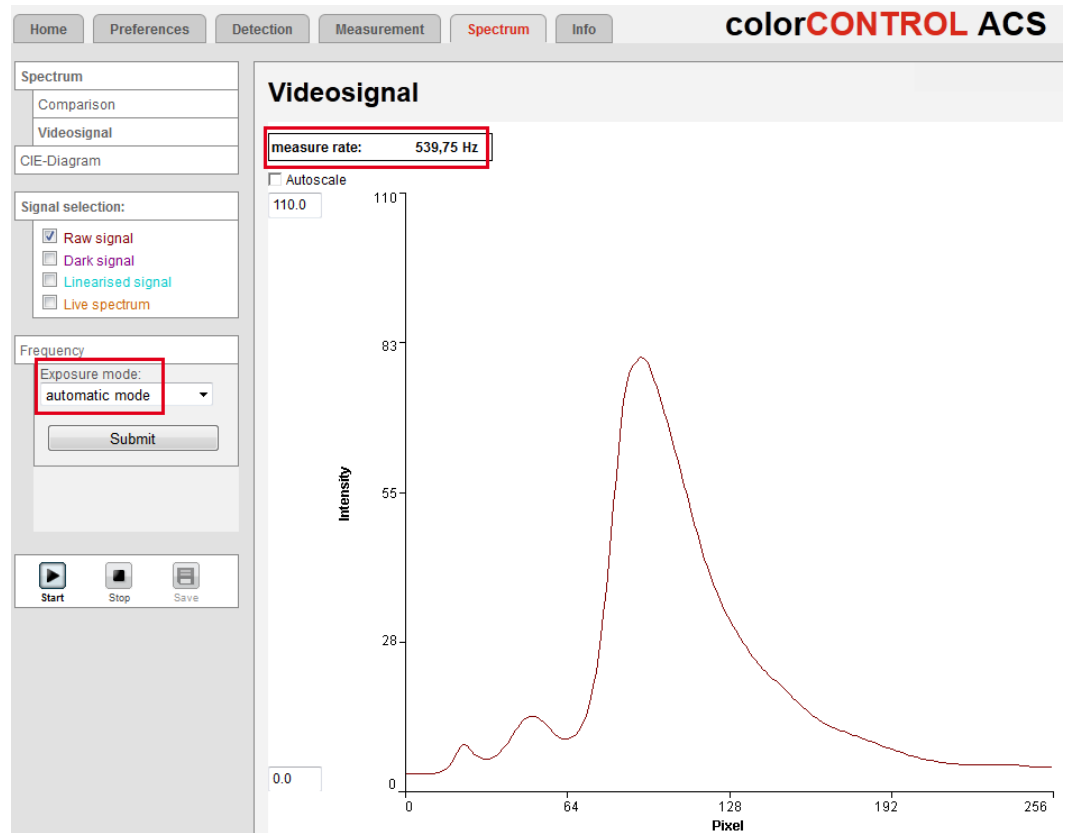

Fig. 30 Determination of the optimum measuring rate

- ➔ Change to the menu Settings > Measuring Rate, Control Behaviour. Select Manual Measuring Rate for the measuring rate and enter the just determined optimum measuring rate or a somewhat larger one (integer) in the Manual Measuring Rate field. Confirm the input with Apply.

<p>Optimum measuring rate smaller than required measuring rate:</p> <ul style="list-style-type: none"> - If possible, specify a higher light source brightness (Settings menu) and update the optimum measuring rate. - Set the required measuring rate, Exposure Mode Manual Mode > Measuring Rate. 	<p>Optimum measuring rate larger than required measuring rate:</p> <ul style="list-style-type: none"> - Operate the controller in exposure mode Measurement Mode or Automatic Mode. - Reduce the light source brightness (Settings menu). - Use spectrum and/or measured value averaging; possibly select data reduction.
---	--

Boundary parameters for the selection of the measuring rate

- High or strongly fluctuating outside temperature: reduce light source brightness (service life), measuring rate not less than 50 Hz (dark current) if possible, perform dark and white balance at operating temperature, in the case of strong temperature fluctuations, possibly perform white balance more frequently
- High external light: select bright LED settings, set white LEDs to maximum power (1023)
- High measuring rate with low as possible noise: select bright LED settings, set white LEDs to maximum power (1023)
- Targets with strong fluorescence or strong direct reflections: select measurement or automatic mode

- Strong and rapid fluctuations of the target brightness / color: select manual exposure mode; set measuring rate somewhat higher than optimum measuring rate

5.3.5 Light Source

The `Light Source` parameter determines the brightness of the internal light source. The brightness of the 4 segments of the illumination LEDs can be set individually. In order to achieve balanced illumination for optimum measurement results, it is recommended to use automatic brightness adjustment.

Configuration of the LED segments	Maximum luminance	<i>Factory setting: maximum brightness in all four segments</i>	
	Minimum luminance	<i>Minimal brightness in all segments</i>	
	Manual configuration	<i>Possible control of the individual segments. The reaction of the light source is visible immediately.</i>	
	Automatic adjustment	<i>Enables a one-time brightness adjustment of the illumination LED which determines an optimum spectrum for the selected, manual measuring rate. In doing so, optimum brightness settings for the respective color channels are determined automatically for the light source. The automatic adjustment of the light source guarantees a balanced illumination spectrum for optimum measurement results.</i>	
	LED off / passive operation	<i>The light source is switched off. Controller operates in the mode of selfluminous objects (light sources).</i>	
	Intensity Quadrant: Cold White	Value	50 ... 1023
	Intensity Quadrant: Green	Value	50 ... 1023
	Intensity Quadrant: Warm white	Value	50 ... 1023
Intensity Quadrant: Violet	Value	50 ... 1023	

- i** A new white balance on the system is required after every change of the LED brightness settings. In the case of larger brightness changes, an additional running-in time of 20 to 40 minutes is recommended.

The manual configuration is required to adapt the intensity of the light source to the target. For example, coated glass or paper reacts to a high violet content in the light.

5.3.6 Corrections, Referencing

Dark correction	<i>The dark correction eliminates the influence of the dark signal of the array in the controller.</i>
White balance	<i>A white balance references the system to a white standard.</i>
Light reference	<i>A light reference refers the system to the brightness of a comparison light source. The light reference function is only possible as light source with LED off/passive mode.</i>

Performing dark correction

The controller needs a warming-up time of appr. 40 minutes for this referencing.

- i** No external light must reach the sensor during dark correction.

➡ Cover the sensor with a piece of dark paper and press the `Dark reference` button on the controller or click the `Dark correction` button in the web page. Menu Preferences > Corrections, Referencing.

The illumination LEDs are automatically switched off for the duration of the correction process. During the dark correction, the button lockout in the controller is activated and released again afterwards.

 Fields with a grey background require a selection.

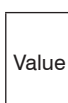
 Dark bordered fields require the specification of a value.

During the dark correction:

- A dynamic field in the top right area in the web interface shows the current progress of the correction process.
- The `Dark reference` LED on the controller flashes green during the dark correction.

After the dark correction:

- The `Dark reference` LED on the controller lights green if the correction was successful, otherwise red (until the next successful dark reference).
- In the web interface, the status line either shows OK or a red error message.

The result of the correction process is stored directly in the controller and does not have to be saved separately in a Setup. If the darkness correction fails, the previous darkness correction continues to be used.

Performing White Balance

The white reference is required after replacement of a sensor or in the case of a changed measuring environment.

- ➡ Change to the menu `Preferences > Corrections, Referencing`.
- ➡ Recommendation: Position a white standard (optional accessory) into the permissible measurement distance of the sensor.
- ➡ Click on the `White balance` button in the web interface or press the `White reference` button on the controller.

During the white referencing:

- A dynamic field in the top right area in the web interface shows the current progress of the correction process.
- The `White reference` LED on the controller flashes green during the correction.

After the white referencing:

- The `White reference` LED on the controller lights green if the correction was successful, otherwise red (until the next successful white reference).
- In the web interface, the status line either shows OK or a red error message.

The result of the correction process is stored directly in the controller and does not have to be saved separately in a Setup. If the whiteness reference fails, the previous white balance continues to be used.

- Do not change the light source brightness of the LED after a white balance.
- 1 Repeat the white balance after a change of the light source.

Performing light reference

The light reference is used to refer the measurement of color of light to the brightness of a comparison light source. The measurement is scaled so that the maximum value of the spectrum is in the range of 400 to 750 nm.

- The light reference function is only possible as light source with LED off/passive mode.
- 1
- ➡ Change to the `Preferences > Corrections, Referencing` menu.
- ➡ Recommendation: Put the reference light source in the measurement position and then turn it on.
- ➡ Click the `Light reference` button or press the `White reference` button on controller.

During the light reference:

- In the web interface a dynamic field in the upper right range informs about the actual progress of the correction process.
- The `White reference` LED on the controller flashes green during the correction.

After the light reference:

- The *White reference* LED on the controller flashes green, when the correction was successful, otherwise red (until the next successful white balance).
- The status bar in the web interface displays either O. K. or a red error message.

The result of the correction process is saved directly in the controller and must not be saved separately in a setup. If the light reference fails, the previous light reference is used further.

5.3.7 Standard Observer, Illuminant, Color Difference

The standard observer and the standard illuminant describe the adopted observation conditions for the calculation of the color values from the spectral reflection function.

Standard observer	2 degrees / 10 degrees
Standard illuminant	D50 / D65 / D75 / F4 / F7 / F11 / A / C / E

The standard observer can have a viewing angle (field of vision of the observer) of 2 ° or 10 °. The standard light types A, C and D65, the light types D50, D75, F4, F7 and F11 as well as the equi-energy spectrum E can be selected in the standard light type field.

i Only color values with the same standard observer and the same illuminant can be directly compared with each other. Explanations of the terms standard observer and standard light types can be found in the standard DIN 5033-2:1992-05.

The distance model describes the model used for color detection. For some models, weighting parameters can be set.

Distance model	Ball (Delta E, DIN99, CIE94) / cylinder / box			
	Ball (CIE94, CIEDE2000)	Factor KL	<i>Value</i>	0.0 ... 3.0
		Factor KC	<i>Value</i>	0.0 ... 3.0
		Factor KH	<i>Value</i>	0.0 ... 3.0
	Ball (CMC)	Factor KL	<i>Value</i>	0.0 ... 3.0
		Factor KC	<i>Value</i>	0.0 ... 3.0

 Fields with a grey background require a selection.

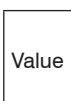
 Dark bordered fields require the specification of a value.

5.3.8 Color Management

5.3.8.1 Color Table

The colorCONTROL ACS7000 color measurement system can store up to 16 different colors in the internal color table to use them for the color recognition.

Color space	L*a*b* / XYZ		
Tolerances (type)	Ball / cylinder / box		
Tolerance value	ΔE^*	Value	0.000 ... 64.000
	$\Delta L^* / \Delta a^* b^*$	Value	0.000 ... 64.000
	$\Delta L^* / \Delta a^* / \Delta b^*$	Value	0.000 ... 64.000
Mode	Binary (0..15) / color 1..4 / L* , a* , b* check		
	Binary format	1 corresponds to 0001 / 1 corresponds to 1000	

Color space, tolerances. Each color is described by the color space coordinates and the permitted tolerances. Depending on the color space, up to three tolerance limits per color can be specified. If the current measured value is within these tolerances, the color is recognized and signalled. The tolerance value can also be changed in the color recognition program.

Mode. If the controller detects a color within the tolerance limit, it indicates the color switching output visually in the column ColorOut.

ColorOut	Color	ColorOut	Color	ColorOut	Color	ColorOut	Color	ColorOut	Color
Mode: BINARY		Mode: BINARY		Mode: CHANNEL		Mode: CHANNEL		Mode: LAB-CHECK	Farbe
1. ●●●●●●	Marine	1. ●●●●●●	Marine	1. ●●●●●●	Marine	1. ●●●●●●	Marine	1. ●●●●●●	Marine
2. ●●●●●●	Apple	2. ●●●●●●	Apple	2. ●●●●●●	Apple	2. ●●●●●●	Apple		Apple
3. ●●●●●●	Brown	3. ●●●●●●	Brown	3. ●●●●●●	Brown	3. ●●●●●●	Brown		Brown
4. ●●●●●●	Carmine	4. ●●●●●●	Carmine	4. ●●●●●●	Carmine	4. ●●●●●●	Carmine		Carmine
5. ●●●●●●	White	5. ●●●●●●	White		White		White		White
6. ●●●●●●	Blue	6. ●●●●●●	Blue		Blue		Blue		Blue
Binary, 1 relates to 0001		Binary, 1 relates to 1000		Color 1..4, 1 relates to 0001		Color 1..4, 1 relates to 1000		L* , a* , b* check	

Input color value manually: For colors which have been entered using different standard observer or standard illuminant from the current settings, the field Properties is highlighted in color.

Color value saved as a spectrum: For colors which have been taught using different standard observer or standard illuminant from the current settings, the color value is recalculated automatically.

The arrangement of the color entries and thus the assignment of colors to the switching outputs can be changed using “Drag & Drop”.

ColorOut	Color	Properties Observer, Illuminant, spectrum stored	Color space: L*a*b*			Tolerances: Box		
			L*	a*	b*	ΔL^*	Δa^*	Δb^*
1	Apple	2°, D65, Spectrum	75.700	-45.163	54.238	1.000	1.000	3.000
2	Marine	2°, D65, Spectrum	47.718	-6.239	-9.111	1.000	2.000	1.000
3	Brown	2°, D65, Spectrum	73.836	0.672	32.042	2.000	1.000	1.000
4	Carmine	2°, D65, Spectrum	55.916	52.776	37.791	3.000	1.000	1.000

Fig. 31 Extract from the Color table menu

5.3.8.2 Create, Edit Teach Color

i Before creating a new color, specify the parameters for the standard observer and the standard illuminant. See menu Preferences > Standard observer, illuminant.

If the color is stored as a spectrum, the parameters for the standard observer and standard illuminant also be changed afterwards. The color values are then recalculated.

Fields with a grey background require a selection.

Dark bordered fields require the specification of a value.

Color name	Value	max. 16 characters, no umlauts and special characters	
Color description	Value	max. 64 characters, no umlauts and special characters	
Description by	Teach via spectrum / manually in the L*a*b* color space / manually in the XYZ color space		
	L*	0 ... 130 (150)	Value
	a*, b*	-130 ... + 130	Value
	X, Y, Z	0 ... 130	Value
Standard observer	Value	Read only. Setting is performed in the "Standard observer, illuminant" menu	
Standard illuminant	Value	"Standard observer, illuminant" menu	

Teach via spectrum. The controller determines the color values from the measured spectrum of the target. Press the `Determine` and `teach color` button to measure the spectrum.

Manually in the L*a*b* color space, manually in the XYZ color space. If color space data (L*a*b*, XYZ) are input manually, the controller discards the spectrum of the color, if one was previously stored in this memory. When teaching a new color spectrum is not available. Spectral comparison of the color and an automatic recalculation of the color values with changes of standard illuminant or standard observer is thus no longer possible. Press the `Apply` button to adopt the settings in the color table.

It is also possible to teach a new color by pressing the `Teach color` button on the controller. The `Teach color` LED on the front panel indicates this, see Chap. 4.3.

Default values are initially used for the tolerance parameters.

New taught colors are also stored after switching off the controller.

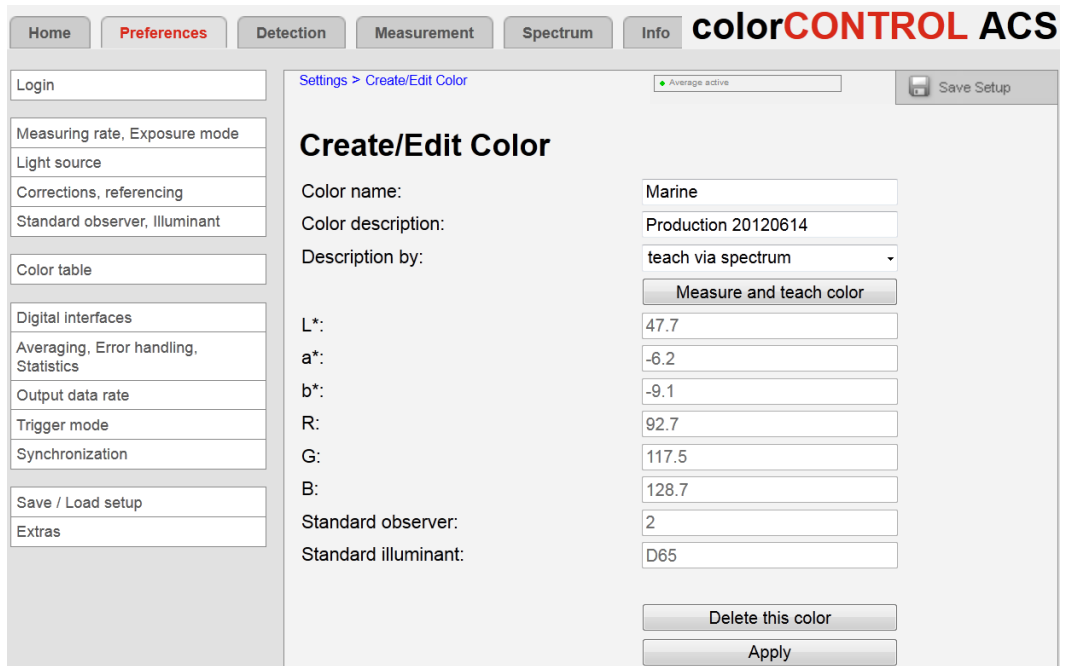

Fig. 32 Extract from the "Create / edit color" menu

A individual color can be removed from the color table using the `Delete this color` button.

`Save`. Saves the color values of the taught color for all color spaces as CSV file.

`Export`. Exports the measurement data (spectrum) in the controller's own format.

`Select data set`. Select a color data set for import.

`Import`. Imports an external saved color in the color table using a controller specific format.

5.3.9 Digital interfaces

5.3.9.1 Parameters Overview

Interfaces and data selection	Web diagram, ColorOut / Ethernet measured value transmission / RS422	<i>Defines which interface is used for data output. No parallel data output via multiple channels. Exception is ColorOut (color switching outputs) and the web interface.</i>	
Measuring program	Color measure / color detection / video, spectrum	<i>The user defined measured values are output in the "color measure and color detection" measuring program. The data packets must be requested manually in the "video / spectrum" measuring program.</i>	
	Color selection mode	Best Hit / Selection	<i>Is respected in the color detection mode only.</i>
Web diagram, color measure		<i>No selection possible</i>	
Web diagram, color detection, best hit	no selection / number of the detected color via ColorOut	<i>Select the relevant check boxes to choose which data are used for transmission. The data are output one after the other in a defined sequence.</i>	
Web diagram, color recognition, selection	no selection / number of the detected color		
Web diagram, video/spectrum	<i>No selection possible</i>		
Ethernet, color measure	Measured data in XYZ / measured data in RGB / measured data in L*a*b* / measured data in L*u*v* / L*c*h* / L*a*b*99 / L*c*h*99 Frequency and control events / Exposure time in digits / Detector temperature / Light source temperature / Light sensor brightness / Light sensor blue / Light sensor green / Light sensor red / Profile counter / Timestamp / Error codes		
Ethernet, color detection, best hit	Measured data in L*a*b* / number of detected color / number of nearest color / minimal color distance Frequency and control events / Exposure time in digits / Detector temperature / Light source temperature / Light sensor brightness / Light sensor blue / Light sensor green / Light sensor red / Profile counter / Timestamp / Error codes		
Ethernet, color detection, selection	Measured data in L*a*b* / number of detected color / number of nearest color / color distance No.: 01 / color distance No.: 02 / ... / color distance No.: 16 Frequency and control events / Exposure time in digits / Detector temperature / Light source temperature / Light sensor brightness / Light sensor blue / Light sensor green / Light sensor red / Profile counter / Timestamp / Error codes	<i>Selection of taught colors to those the color distance should be issued.</i>	
Ethernet, video/spectrum	Detector signal / Dark corrected signal / Linearized signal / Spectrum Frequency and control events / Exposure time in digits / Detector temperature / Light source temperature / Light sensor brightness / Light sensor blue / Light sensor green / Light sensor red / Profile counter / Timestamp / Error codes		

RS422, color measure	Measured data in XYZ / measured data in RGB / measured data in L*a*b* / measured data in L*u*v* / Frequency and control events / Exposure time in digits / Detector temperature / Light source temperature / Light sensor brightness / Light sensor blue / Light sensor green / Light sensor red / Profile counter / Timestamp / Error codes		Select the relevant check boxes to choose which data are used for transmission. The data are output one after the other in a defined sequence.	
RS422, color detection, best hit	Measured data in L*a*b* / number of detected color / number of nearest color / minimal color distance Frequency and control events / Exposure time in digits / Detector temperature / Light source temperature / Light sensor brightness / Light sensor blue / Light sensor green / Light sensor red / Profile counter / Timestamp / Error codes			
RS422, color detection, selection	Measured data in L*a*b* / number of detected color / number of nearest color Frequency and control events / Exposure time in digits / Detector temperature / Light source temperature / Light sensor brightness / Light sensor blue / Light sensor green / Light sensor red / Profile counter / Timestamp / Error codes			
RS422, video/spectrum	Frequency and control events / Exposure time in digits / Detector temperature / Light source temperature / Light sensor brightness / Light sensor blue / Light sensor green / Light sensor red / Profile counter / Timestamp / Error codes			
Ethernet settings	IP settings of the device		Static IP address / DHCP	Values for IP address / gateway / subnet mask. Only for static IP address
	Ethernet measured value transfer settings		Server / Client	Values for port and IP address TCP/IP / UDP/IP
Settings RS422	Baud rate		9.6 / 115.2 / 230.4 / 460.8 / 691.2 / 921.6 / 1500 / 2000 / 3500	
Settings Color-Out	Output mode	no output / binary (0..15) / color (1..4) / L*, a*, b* check	Use of the four color switching outputs, see Chap. 4.4.4. Use of the optical presentation ColorOut in the "Color Table" menu and in the "Color Detection" slide.	
	Binary format	1 corresponds to 0001 / 1 corresponds to 1000		
	Reference color	see Preferences > Color table menu (in L*a*b*-Check mode only)		
Settings Ether-CAT	Operating mode after system start		Ethernet / EtherCAT	

Color measurement. Output of the color values determined for the target. The color space and the measurement conditions (standard light type / standard observer) are specified by the user for this. The measured values are output automatically.

 Fields with a grey background require a selection.

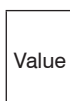
 Dark bordered fields require the specification of a value.

Color detection. Output of a recognition signal if the measured color is within a specified tolerance range around any of the specified reference colors (color table). The measured values are output automatically.

Video / Spectrum. Output of the measured spectral reflection function of the target or the recorded signal of the detector array. The data packets must be requested manually.

Best Hit. With the Best Hit mode the system automatically determines from all trained colors, the color with the shortest distance to the currently measured color. One or more distances to this color could then be output. Alternatively, in the selection mode, colors could be selected, on which one or more distances should be output. Multiple selection is possible. Regardless of this mode, the number of the detected color and the number of the color with the minimum color distance could be selected.

Selection. Output of the number of the recognized color and color distance to selected color(s). Only possible when using the Ethernet or RS422 interfaces. One or several colors can be selected for analysis. If more than one color or Best Hit mode is selected, the system automatically determines the color with the smallest color distance and then checks the individual distances.

Binary (0..15). 15 colors can be signalled via the four color switching outputs using binary coding.

Color (1..4). In this mode, a color switching output is exclusively assigned to each of the four possible colors. If this color is recognized, it is signalled via the corresponding channel.

L*, a*, b* check. In this mode, all four color switching outputs are assigned to a selected color. If the L*, a* or b* parameter is within the respective tolerance limits, this is output via each switching output.

5.3.9.2 Selecting a Digital Interface

The controller has three digital interfaces that can be used alternatively for data output in parallel with the parameterization. Ethernet and EtherCAT cannot be used in parallel.

- Ethernet: enables fast data transfer, but provides no real-time capabilities (packet-based data transfer). Both measurement and video data can be transferred. Use to capture measured values without any direct process control, for subsequent analysis. The parameterization is performed using the web interface or ASCII commands.
- RS422 : provides a real-time capable interface with a lower data rate.
- EtherCAT: enables fast data transmission with real-time capability. The TwinCAT (from Beckhoff) software is required on the PC for this. The parameterization is performed exclusively using service data objects; the web interface cannot be used in parallel with this. The HyperTerminal® program provides an interface for serial communication with the controller using RS422, and Telnet® is used for Ethernet connections; the “TwinCAT” program can be used for EtherCAT.

5.3.9.3 Ethernet

When using a static IP address, you need to specify values for IP address, gateway and subnet mask. This is not necessary when using DHCP.

The controller is set to the static IP address 169.254.168.150 at the factory.

The controller transmits TCP/IP or UDP/IP packets with an Ethernet transfer rate of 10 Mbit/s or 100 Mbit/s. The transfer rate is selected automatically depending on the connected network or PC.

All output values and additional information to be transmitted that are logged at one point in time are combined to form a measured value frame. Multiple measured value frames are combined into one measurement block and enclosed by another header. The header must be located at the start of a UDP/IP or TCP/IP packet. One current header per packet is always transmitted.

When transmitting measurement data to a measured value server, following successful connection (TCP or UDP), the sensor sends each measured value to the measurement server or to the connected client. No explicit request is necessary for this.

If any changes are made to the transmitted data or the frame rate, a new header will be sent automatically.

All color values and color distances: Binary format with comma. There are 10 digits plus sign in front of the decimal point, and 7 digits decimal places for the RS422. There are 10 digits plus sign in front of the decimal point, and 10 digits decimal places for other interfaces.

Video signals are transmitted the same way as measurement data are sent to a measurement server via Ethernet with the difference: only one video signal per measurement block is transmitted, and each video signal must be requested individually.

This measured value block can be sent using several TCP/IP or UDP IP packets, depending on the size of the video signal.

5.3.9.4 RS422 Interface

The RS422 interface has a maximum baud rate of 3500 kBaud. The baud rate in the delivery condition is set to 115.2 kBaud. Use ASCII commands or the web interface to configure.

Transfer settings for controller and PC must match.

Data format: Binary. Interface parameters: 8 data bits, no parity, 1 stop bit (8N1) Selectable baud rate.

The data format of the output values depends on the selected measured value.

All color values and color distances: 9 bits with no decimal places (with sign), 9 bits with decimal places. Values always in 18-bit blocks.

Up to 32 output values can be transmitted in parallel.

The maximum number of measured values that can be transferred for a measuring point depends on the controller measuring rate and the specified RS422 interface transmission rate. Where possible, use the maximum available transmission rate (baud rate).

5.3.9.5 ColorOut

The assignment of the physical color switching outputs Out 1 ... Out 4 is also performed using the `Output Mode` and `Binary Format` resp. `Reference color` parameters, see Chap. 4.4.4, see Chap. 5.3.8.1.

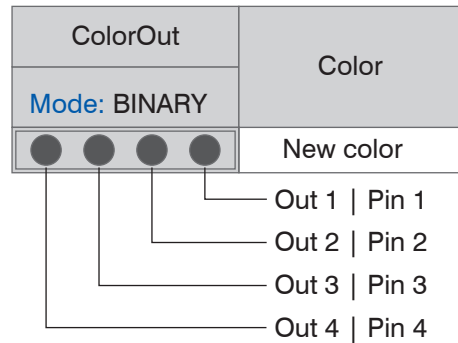

This switching output, see Fig. 10, becomes active, if the measured color is within the predefined parameters (L^* a^* & b^*). The color is considered to be detected.

Fig. 33 Color switching outputs assignment

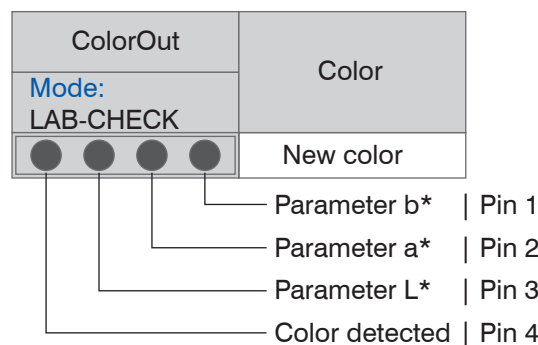

The pins 1 up to 3 get active,

- if operation mode `LAB check` is used for the `ColorOut` output and
- if the measured color is within the tolerances of the `Reference color`.

Pin 4 gets active, if all three values are within the tolerances.

Fig. 34 Assignment L^* , a^* , b^*

5.3.9.6 EtherCAT

The interface enables fast transmission of the measured values. CANopen over EtherCAT (CoE) is implemented in the controller.

Service Data Objects (SDO): All parameters of the controller can be read or changed with these; all measured values and also the dark corrected video signal can also be retrieved individually.

Process Data Objects (PDO): A PDO telegram is used for real-time transmission of measured values. No individual objects are addressed here, but the contents of the previously selected data are sent directly.

- All color values and color distances: 9 bits with no decimal places (with sign), 10 bits with decimal places. Values always in 32-bit blocks.

Details can be found in the Appendix, see Chap. A 4.

The changeover to the EtherCAT interface via the web page is not performed immediately. It is performed after restarting the controller. The web page is then no longer available.

Instructions for changing back to Ethernet from the EtherCAT interface can be found in the Appendix, see Chap. A 4.

5.3.10 Averaging, Error Handling, Statistics

5.3.10.1 Parameters Overview

Video averaging	<i>no averaging / Recursive 2 / 4 / 8 / 16 / 32 / 64 / 128</i>			<i>The video averaging is performed before the calculation of the color values. Recommended for very dark objects and for output of the video data.</i>
Color value averaging	<i>no averaging</i>			<i>Specify the type of averaging. The averaging number N states over how many sequential color values in the controller should be used for calculating the averaged color value.</i>
	<i>Moving N values</i>	<i>2 / 4 / 8 ... 1024</i>	<i>Value</i>	
	<i>Recursive N values</i>	<i>2 ... 32768</i>	<i>Value</i>	
	<i>Median N values</i>	<i>3 / 5 / 7 / 9</i>	<i>Value</i>	
Error handling	<i>Error output, no measured value</i>			<i>Sensor outputs an error value.</i>
	<i>Keep last value</i>	<i>0 ... 1024</i>	<i>Value</i>	<i>If no valid measured value can be determined, the last valid value can be retained for a certain period of time, and will be output repeatedly. In the case of "0", the last valid value is retained permanently.</i>
Statistics	<i>2 / 4 / 8 / 16 ... 16384 / all values</i>			<i>The statistical values for Minimum, Maximum and Peak-to-Peak are determined over a specified number of measured values and output.</i>

Averaging can be performed in two different signal processing areas in the controller.

- Video averaging
- Color value averaging (Measured values averaging)

It is recommended to use averaging for statistical measurements or slowly changing measured values. Averaging reduces noise or suppresses distortions in the measured values.

The controller is shipped from the factory with the defaults `no video averaging` and `no measured value averaging`.

5.3.10.2 Video Averaging

The following video graphs can be averaged successively and pixel by pixel in the controller. The effect of the different settings can be seen in the web browser in the `Spectrum` program. Video averaging is particularly recommended for very dark colors and for the output of spectra.

5.3.10.3 Color Value Averaging

Measured value averaging is performed after measurement values have been calculated, and before they are output via the interfaces or their further processing.

Measured value averaging

- improves the resolution
- allows masking individual interference points or
- the measurement result is "smoothed".

The internal average value is recalculated in each measuring cycle.

i The defined type of average value and the number of values must be stored in the controller to ensure they are retained after it is switched off. Averaging has no effect on the measuring rate and output rate.

 Fields with a grey background require a selection.

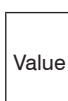
 Dark bordered fields require the specification of a value.

Moving Average

Using the selectable number N of sequential color values (window width), the arithmetic mean M_{gl} is calculated according to the following formula and output:

$$M_{mov} = \frac{\sum_{k=1}^N MV(k)}{N}$$

MV = measured value
 N = averaging number
 c = continuous index (in the window)
 M_{mov} = average value or output value

Each new color value is added, the first (oldest) color value is removed from the averaging (from the window). In this way, short response times for measured value jumps are achieved.

Example: $N = 4$

$\dots 0, 1, \underline{2, 2, 1, 3}$ \downarrow $\frac{2, 2, 1, 3}{4} = M_{mov}(n)$	$\dots 1, 2, \underline{2, 1, 3, 4}$ \downarrow $\frac{2, 1, 3, 4}{4} = M_{mov}(n+1)$	Measured values Output value
---	---	-------------------------------------

i Moving average in the controller only allows the powers of 2 for the averaging number N. The highest averaging number is 1024.

Recursive Average

Formula:

$$M_{rec}(n) = \frac{MV(n) + (N-1) \times M_{rec}(n-1)}{N}$$

MV = measured value
 N = averaging value, $N = 1 \dots 32768$
 n = measured value index
 M_{rec} = average value or output value

The weighted value of each new color value $MV(n)$ is added to the sum of the previous average values $M_{rec}(n-1)$.

The recursive averaging enables very strong smoothing of the color values; however it needs very long response times for measured value jumps. The recursive average value shows low-pass behavior.

Median

The median is formed from a preselected number of color values.

When creating a median value in the controller, incoming color values are sorted after each measurement. Afterwards, the average value is output as the median.

3, 5, 7 or 9 color values are taken into account. This means that individual interference pulses can be suppressed. However, the smoothing of the measured value curves is not very strong.

Example: Median value from five measured values

$\dots 0 \ 1 \ \underline{2 \ 4 \ 5 \ 1 \ 3}$	\rightarrow Sorted measurement values: 1 2 3 4 5	Median
$\dots 1 \ 2 \ \underline{4 \ 5 \ 1 \ 3 \ 5}$	\rightarrow Sorted measurement values: 1 3 4 5 5	Median

5.3.10.4 Error Handling (Hold Last Value)

If no valid measured value can be determined, an error is output. If this is a problem for further processing, the last valid value can be retained for a certain period of time and will be output repeatedly.

Between 1 and 1024 values can be retained.

If the number is 0, the last value is retained until a new, valid measured value appears.

5.3.10.5 Statistics

The controller derives the following statistical values from the measurement result:

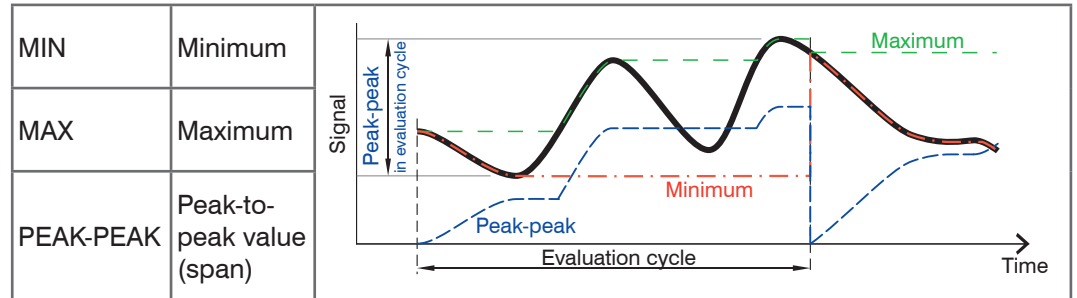

Fig. 35 Statistical values and evaluation cycle

Statistical values are calculated from measured values within the evaluation cycle. The number of measured values used for calculation can be between 2 and 16384 (in powers of 2) or include all measured values.

Use the `Reset Statistics` button or the `RESET STATISTICS` command to start a new evaluation cycle (storage period). When a new cycle starts, previous statistical values are deleted.

Statistical values are displayed in the web interface, `Color Measurement` program or are output via the interfaces.

5.3.11 Output Data Rate

Every (Measured value)	<i>Value</i>	<i>Only every n-th value is output (n = 1, 2 ... 1000). All other measured values are discarded.</i>
Reduction interfaces	RS422 / Ethernet	<i>Select the relevant check boxes to choose which interfaces are used for data reductions.</i>

In the case of reduction of the output data rate, the measuring rate remains unchanged, i.e. output data rate ≤ measuring rate.

Fields with a grey background require a selection.

Value
Dark bordered fields require the specification of a value.

5.3.12 Trigger Mode

The digital measured value output on the colorCONTROL ACS7000 can be controlled by an external electrical trigger signal or by a command.

- Triggering does not affect the preset measuring rate.
- The Sync input is used as external trigger input.
- Factory settings: no triggering, the controller starts transmitting data as soon as it is switched on.
- "Sync in" signal pulse duration is at least 5 μ s.

<i>Level triggering</i>	Level low / level high		
<i>Edge triggering</i>	Start of the measured value output with	falling edge / rising edge	
	Number of measured values	Value	0 ... 16383
<i>Software triggering</i>	Number of measured values	Value	0 ... 16383
<i>No triggering</i>	<i>continuous measured value output</i>		

Level triggering. Continuous measured value output for as long as the selected level is active. Afterwards, the controller stops the measured value output. The duration of the pulse must be at least one cycle time. The subsequent pause must also be at least one cycle time.

Maximum trigger frequency = 0.5 x measuring rate.

Fig. 36 Triggering with active High level (T_I), associated measured values (M) and output signal (D_o)

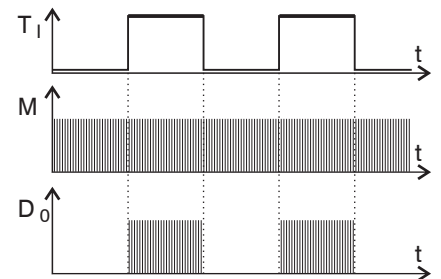

Edge triggering. Starts measured value output as soon as the selected edge is present at the trigger input. If the trigger condition is met, the controller outputs the specified number of measured values. Value range between 0 and 16383.

The duration of the pulse must be at least 5 μ s.

Fig. 37 Triggering with falling edge (T_I), associated measured values (M) and output signal (D_o)

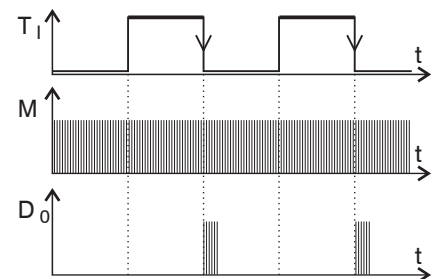

Software triggering. Starts the measured value output as soon as a software command (instead of the trigger input) or the Initiate Trigger button is pressed. The point in time is defined imprecisely. If the trigger condition is met, the controller outputs the specified number of measured values. Value range between 1 and 16383. The measured value output can be ended using a command.

Number of measured values. 0 = end output, value (1 ... 16382), 16383 = output continuously.

5.3.13 Synchronization

If two controllers measure the same target synchronously, the controllers can be synchronized with each other. The synchronization output of the first controller *Master* is connected to the synchronization input of the second controller *Slave*, see Chap. 4.4.7.

<i>Master on</i>	<i>First controller in the measuring chain; synchronizes all subsequent controllers.</i>
<i>Slave in</i>	<i>Controller operates dependent on the first controller or external source.</i>

External synchronization. Sync In at the controller is used by an external synchronization source such as a PLC or frequency generator. Synchronization frequency 20 Hz to 2 kHz. It is also possible to simultaneously synchronize multiple controllers externally.

5.3.14 Save / Load Setup

This menu enables you to save the controller data or to read saved data back into the controller.

- Save the controller settings before exporting or importing data.

Setup No.	1 / 2 / 3 ... 8	<i>You can permanently store eight different parameter sets in the controller.</i>
Maintain interface settings	<i>Checkbox</i>	<i>Interface settings include network properties, such as the baud rate for the RS422 interface.</i>

How to store settings:

- Select the Setup No.
- Make the selection whether interface settings are involved.
- Click the *Save Setup* button.

The settings should always be saved at the end of programming the controller. You can also use the *Save Setup* button at the top right on every settings page for fast intermediate saving to the last saved parameter set.

- Switching on the controller loads the set of parameters that was last stored into the controller.

How to load settings:

- Select the Setup No.
- Make the selection whether interface settings are involved.
- Click the *Activate* button.

Retain the interface settings if the controller will be operated on the same network and with the same baud rate on the RS422 (checkbox *Interface Settings* not active). The controller now uses the settings from the selected parameter set.

5.3.15 Export, Import all Setups

Using this function, you can transfer all saved setups in the controller at once to a PC / network or load into the controller.

How to export all setups to PC / network:

- Change to the menu *Settings > Load / save settings > Backup & Restore*.
- Make the selection whether interface settings are involved.
- Click the *Export Setups* button.

How to load all setups into the controller:

- Click on the *Browse* button and input the path.
- Click the *Import Setups* button.

5.3.16 Manage Setups on PC

Use this menu to save a backup copy of the controller data to a PC or to restore backed up setup files to the controller. This function can also be used to configure an additional controller.

i Save the controller settings before exporting or importing data.

Select data for transmission	Setup / Color Table	Depending on the interface settings, a Setup contains all controller parameters except the color table.
Setup No.	1 / 2 / 3 ... 8	You can permanently store eight different parameter sets in the controller.
Maintain interface settings	Checkbox	Interface settings include network properties, such as the baud rate for the RS422 interface.
Select setup file	Value	Path specification for the file to be loaded into the controller.

Step by Step:

➤ Select the data to be transmitted.

The color table

- can not be saved together with the setup,
- can only be saved on a connected PC / network.

➤ Specify the Setup No.

➤ Make the selection whether interface settings are involved.

Exporting data:

➤ Click the `Export Setup` button or `(Export Color Table)`.

A Windows dialog box for saving the file opens.

➤ Enter the file name for the parameter set file (*.meo), and click `OK`.

The currently selected files will be backed up to the PC.

Importing data:

➤ Click the `Browse` button or `(Import Color Table)`.

A Windows dialog box for selecting the file opens.

➤ Click the `Import Setup` button.

The PC starts transferring the file to the controller.

5.3.17 Extras

Language/Sprache		<i>Deutsch / English</i>	<i>Language of the interactive web pages.</i>
Factory settings	Only reset color table	<i>Checkbox</i>	<i>If the checkbox is activated, all taught colors are reset and a default database is loaded.</i>
	Keep interface settings	<i>Checkbox</i>	<i>Enables retaining all Ethernet and RS422 interface settings without any changes.</i>
System settings	Keylock active on system startup	<i>Checkbox</i>	<i>The button lockout prevents unauthorized / unwanted execution of the button functions.</i>
	Minutes until automatic keylock is activated	<i>Value</i>	<i>0 ... 65535</i>

Factory settings. If no checkbox is activated, all settings are reset.

Only reset color table. Resets all taught colors and loads a default database.

Keep interface settings. The settings for language, password, color output and network are retained.

Alternatively to the web interface, the factory settings can be invoked using the `Dark reference` and `Teach color` buttons. Press and hold both buttons simultaneously for at least 10 s for this.

- After the reset, the controller is allocated a fixed IP; the communication with the web interface may have to be reestablished.

System settings. The button lockout is always activated if no user in the user level `Professional` is logged in. The buttons will be locked if they have not been used after a restart for a configurable period of time. Press and hold the `Dark Reference` and `White Reference` buttons simultaneously for 3 to 5 seconds to enable or disable the button lockout.

5.4 Detection

5.4.1 Location Chart

Projection plane	$a^*b^* / L^*a^* / L^*b^*$	Illustration of a 2-dimensional projection level from a 3-dimensional color space	
Distance model (tolerance space)	Ball DELTA E; DIN99; CIE94 CMC; CIEDE2000 (ΔE) / cylinder ($\Delta L^*, \Delta a^* b^*$) / box ($\Delta L^*, \Delta a^* b^*$)	Describes the method used for the color recognition, specifies the form of the tolerance space around the reference color value	
Tolerance value	ΔE^*	Value	0.000 ... 64.000
	$\Delta L^* / \Delta a^* b^*$	Value	0.000 ... 64.000
	$\Delta L^* / \Delta a^* / \Delta b^*$	Value	0.000 ... 64.000
Teach color	Button	Saves the currently measured color of the target in the color table. The color table comprises max. 16 colors.	
Signal selection	Checkbox	Selection of available colors which should be shown in the diagram.	
Control element	Start / Stop	The diagram starts automatically with the call of the program.	

➡ Change to the Detection program and select Location chart.

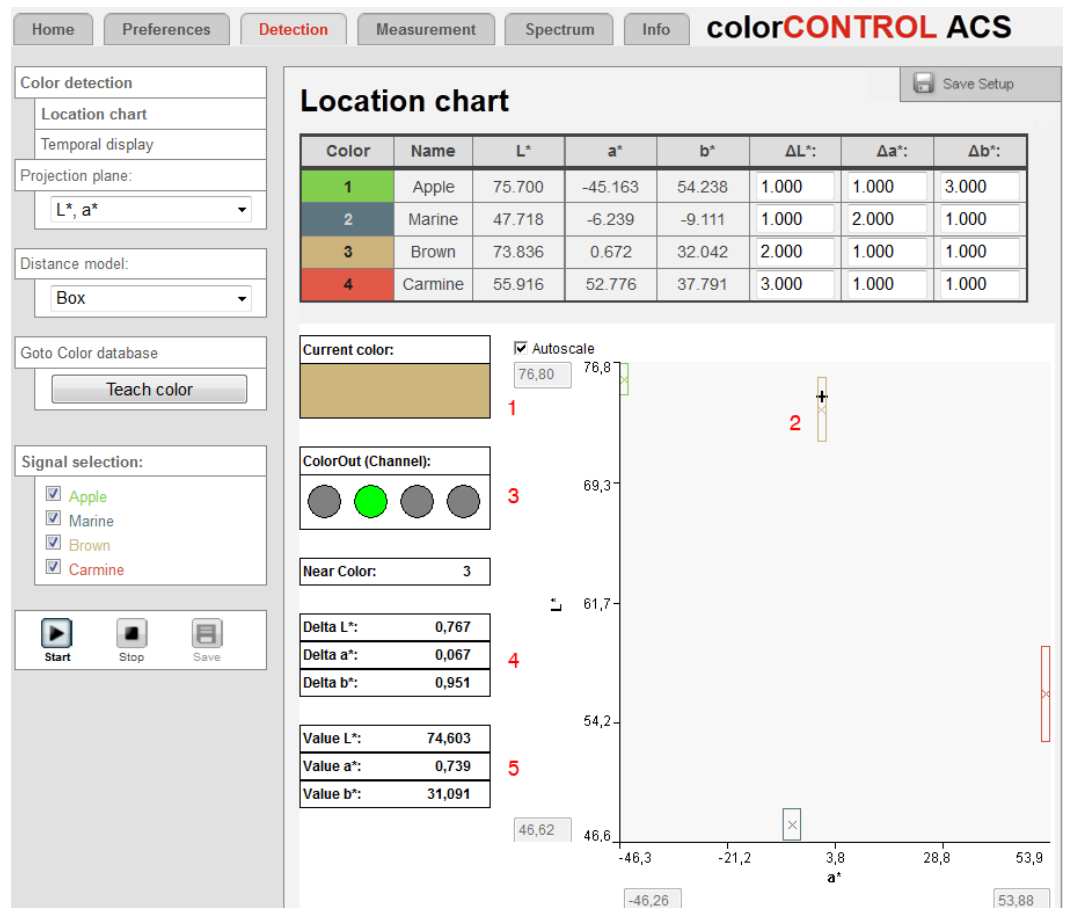

Fig. 38 Location chart program

The currently measured color (1) of the target is shown with the mixed color from the RGB color space and marked in the measurement diagram with a cursor (“+” sign) (2).

Every taught color from the color table is shown in the measurement diagram with a colored cursor and the corresponding tolerance range. If the currently measured color is within the tolerance limits of a taught color, the Color Out digital output (3) is switched depending on the coding, see Chap. 5.3.9.5.

The Nearest Color text box always represents the color with the minimum color

distance to the currently measured color. This happens regardless of whether the tolerance limits are matched or not.

An extra table (4) lists the color distances to the nearest color with minimum color distance in the selected distance model. The distances are also shown if the measured value is not in the tolerance range of any color.

In another table (5), the program combines the three current coordinates (color values, e.g. L^* , a^* , b^*) of the measured color of the color space.

➡ Select the colors to be displayed in the `Signal Selection` section.

The 2D diagram shows the currently measured color and taught colors from a three-dimensional color space.

- The color detection only operates if at least one color has been taught. A color is then detected if the measured color values fulfil all tolerance conditions.
A color displayed on the monitor depends on the monitor settings.

5.4.2 Temporal Display

Distance model (tolerance space)	Ball Delta E; DIN99; CIE94; CMC; CIEDE2000 (ΔE) / cylinder (ΔL^* , Δa^* b^*) / box (ΔL^* , Δa^* , Δb^*)	Describes the method used for the color detection, specifies the form of the tolerance space around the reference color value	
Tolerance value	ΔE^*	Value	0.000 ... 64.000
	ΔL^* / Δa^* b^*	Value	0.000 ... 64.000
	ΔL^* / Δa^* / Δb^*	Value	0.000 ... 64.000
Teach color	Button	Saves the currently measured color of the target in the color table. The color table comprises max. 16 colors.	
Signal selection	Checkbox	Selection of available colors which should be shown in the diagram.	
Control element	Start / Stop / Save	The diagram starts automatically with the call of the program.	

➡ Change to the Color detection program and select Temporal display.

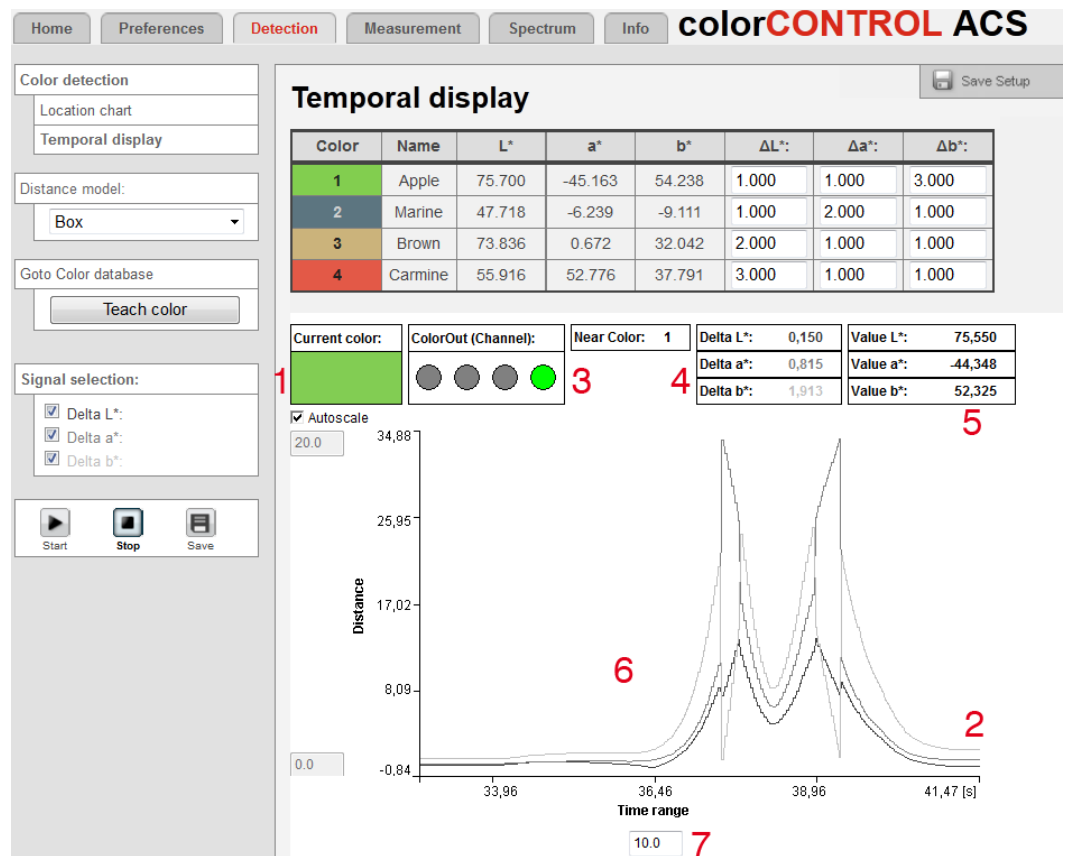

Fig. 39 Time diagram program

The currently measured color (1) of the target is represented by the mixed color from the RGB color space.

The temporal display (time diagram) (6) shows the color distance values over time depending on the selected tolerance model.

If the currently measured color is within the tolerance limits of a taught color, the detected color number is shown in the Near Color text box and the Color Out digital output (3) is switched depending on the coding, see Chap. 5.3.9.5.

An extra table (4) lists the color distances to the nearest color with minimum color distance in the selected distance model. The distances are also shown if the measured value is not in the tolerance range of any color.

In another table (5), the program combines the three current coordinates (color values, e.g. L*, a*, b*) of the measured color of the color space.

Fields with a grey background require a selection.

Dark bordered fields require the specification of a value.

➡ Select the color values to be displayed in the `Signal Selection` section.

The diagram display starts automatically. Use the `Stop` button

- to stop the diagram display,
- to scroll in the diagram using the slider bars and to zoom using the `Time Range window (7)`
- and to save in a CSV file (time column and measured value columns) using the `Save` button.

The right edge of the diagram (2) is the reference for the current color values. The measurement is stopped if the slider bars are operated during a running measurement.

- The color detection only operates if at least one color has been taught. A color is then recognized if the measured color values fulfil all tolerance conditions. A color displayed on the monitor depends on the monitor settings.

5.4.3 Color Tolerance Parameters

The system can be adjusted for the box (cube), cylinder and ball (DELTA E, DIN99, CIE94, CMC, CIEDE2000) distance models. These models form a tolerance space around the taught colors. You can adjust the weighting parameters for the distances CMC, CIE94 and CIEDE2000 on the side standard observer, standard illuminant, setting the color distance, see Chap. 5.3.7.

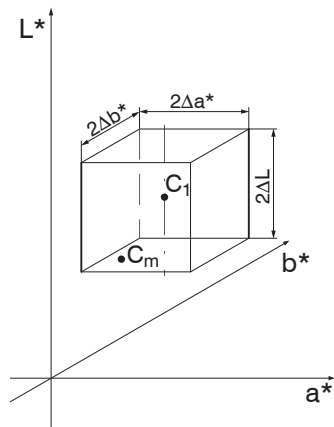

Fig. 40 Box tolerance space

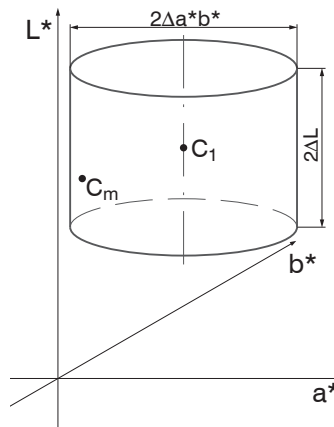

Fig. 41 Cylinder tolerance space

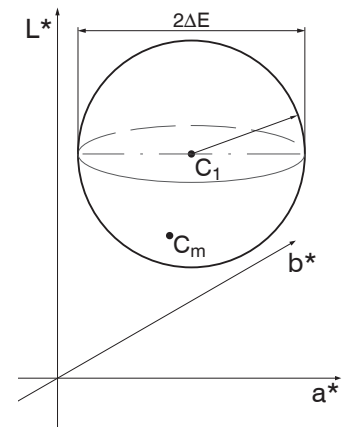

Fig. 42 Ball tolerance space

C_1 = taught color 1

C_m = measured color

The color tolerance parameters should be oriented to the perception thresholds for color differences for an assessment of color deviations. In the $L^*a^*b^*$ color space, a tolerance threshold of $\Delta E > 1$ is frequently used for perceptible color differences.

Influence factors for setting the color tolerance parameters:

- Required accuracy of the color recognition.
- Tolerance of the measured value fluctuations.

A change of color measured values for one and the same sample can have two causes:

- Internal factors. Change of the measured values due to detector noise, brightness changes of the light source and modulated external light.
- External factors. Difference of the targets in color, surface structure and measurement condition (distance, angle).

The individual programs provide tools to estimate the size of the current change. The position diagram in the color recognition program shows the change of the measured values based on the movement of the measuring point in the respective projection level. The time diagrams for the color distances in the color recognition program and the color values in the color measurement program also show slower as well as current trends for the changes of the measured values.

Possibilities for reduced measured value change:

- Reduce measuring rate as, due to a longer exposure time, the signal at the detector
- Averaging of the array signals and/or of the measured values taking account of a reduced temporal resolution.

The color distance tolerances must be defined so that the tolerance limits are greater than the change of the measured values for acceptable targets.

5.5 Color Measurement

Color space	L* a* b* / X Y Z / R G B / L* u* v* / L* C* h* / L* a* b*99 / L* C* h*99	Selection of the color space in which the measured values should be displayed.
ColorOut mode	no output / binary (0..15) / color (1..4) / L*, a*, b* check	Use of the four color switching outputs, see Chap. 4.4.4, for L*, a*, b* check. Otherwise, only display of the tolerance limits in the diagram.
Reference color	Color 1 / Color 2 ... Color 16	Selection of a color from the saved colors in the color table. The tolerances of the comparison color are adopted in the diagram.
Go to statistics	Link	Link leads to the menu Settings > Averaging, error handling, statistics.
Reset statistics	Action button	Reset of the statistics values in the display.
Go to color database	Link	Link leads to the menu Settings > Color table.
Teach color	Action button	Saves the currently measured color of the target in the color table. The color table comprises max. 16 colors.
Control element	Start / Stop / Save	The diagram starts automatically with the call of the program.
Time range	Value	0.0 ... 20.0 s

➔ Change to the Color Measurement program and select the Color space and the Reference color.

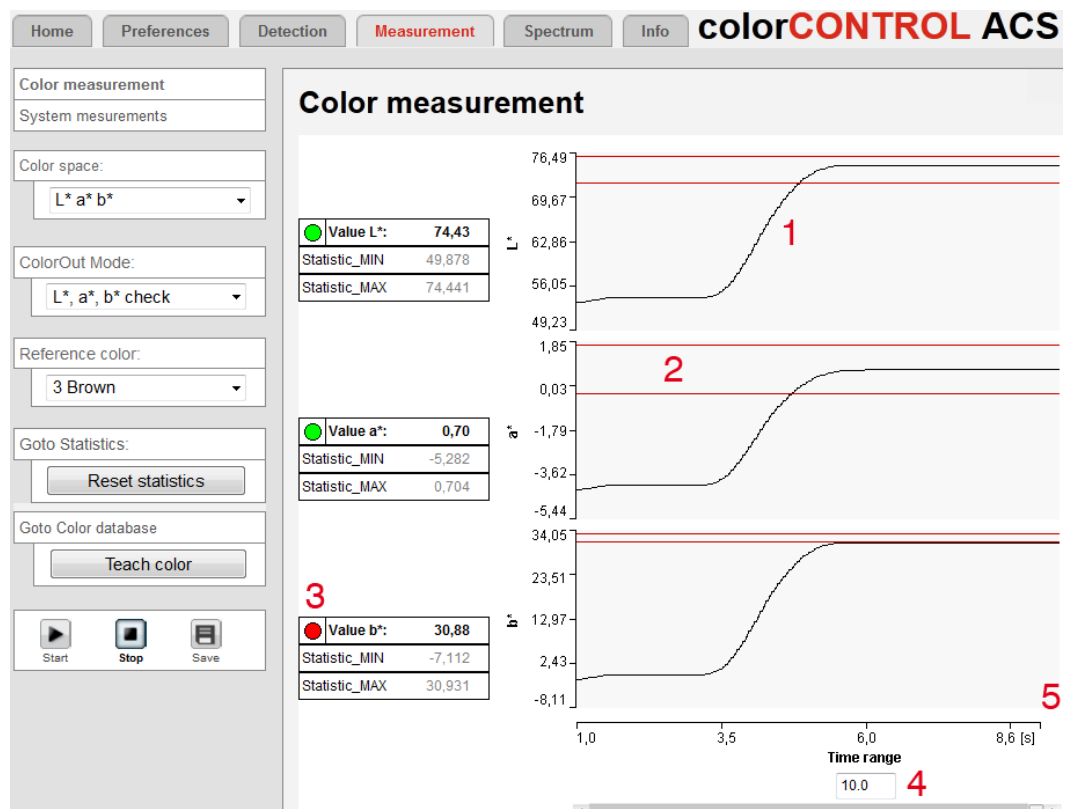

Fig. 43 Color Measurement program

The color measurement diagram (1) shows the time course of the currently measured color in the selected color space.

If you select L*a*b* as color space,

- the tolerance range (2) of the comparison color is shown in positive and negative direction as a red line.

Fields with a grey background require a selection.

Value
Dark bordered fields require the specification of a value.

- shows a colored circle symbol (3) whether the measured value is in the tolerance range (green) or not (red).

The diagram display starts automatically. Use the `Stop` button

- to stop the diagram display,
- to scroll in the diagram using the slider bars and to zoom using the `Time Range` window (4)
- and to save in a CSV file (time column and measured value columns) using the `Save` button.

The right edge of the diagram (5) is the reference for the current color values. The measurement is stopped if the slider bars are operated during a running measurement.

The switching outputs are active in combination with the color space `L* a* b*` and the output mode `L*, a*, b* check` only.

- Use the `Color Measurement` program to determine the tolerance parameters for the `Color Detection` program.

5.6 System

The System program shows the internal temperature of the video array and the light source.

The bar display and the measured value boxes show the light source intensity distributed among the individual red, green and blue color components of the light source. The data allow conclusions to be drawn about the actual brightness of the light source and signs of ageing. However, traceability to the individual segments of the light source is not usually possible.

5.7 Spectrum

5.7.1 Comparison

Signal selection	Checkbox	Selection of available colors which should be shown in the diagram.
Color space	L* a* b* / X Y Z / R G B / L* u* v* / L* C* h* / L* a* b*99 / L* C* h*99	Selection of the color space in which the measured values should be displayed.
Go to color database	Link	Link leads to the menu Preferences > Color table.
Teach color	Action button	Saves the currently measured color of the target in the color table. The color table comprises max. 16 colors.
Control element	Start / Stop / Save	The diagram starts automatically with the call of the program.

➡ Change to the Spectrum program and select Comparison.

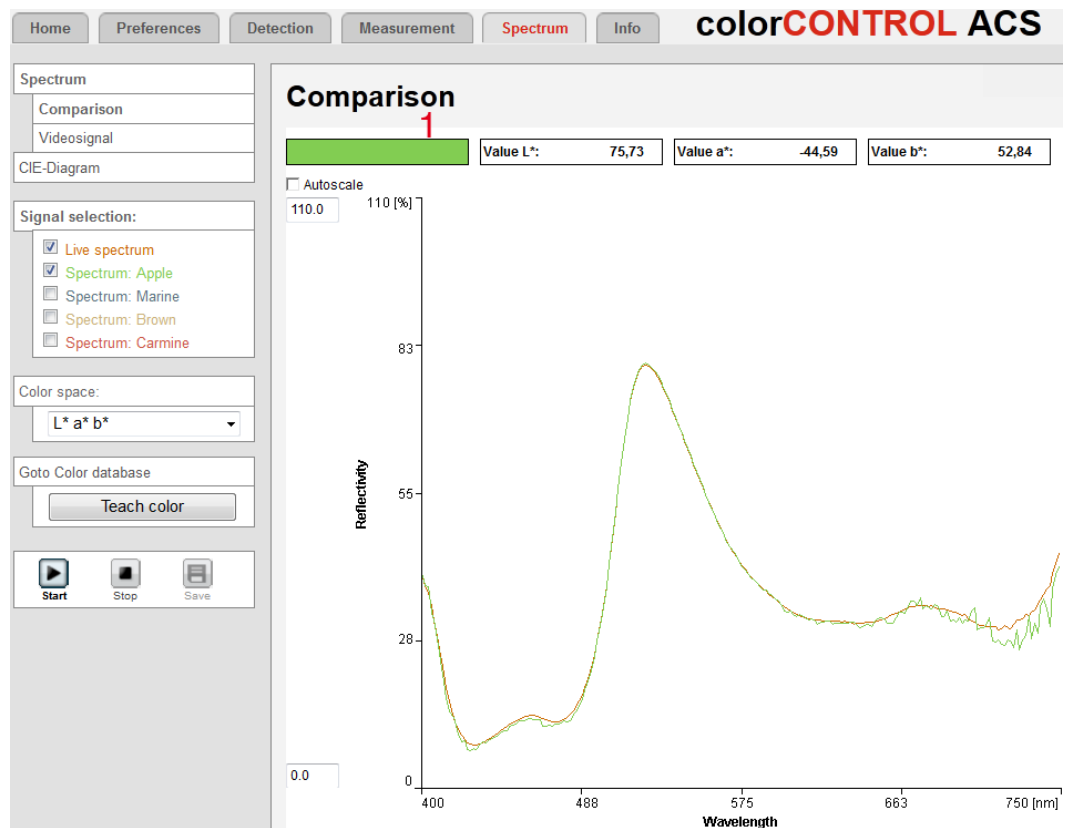

Fig. 44 Spectral Comparison program

Fields with a grey background require a selection.

Value Dark bordered fields require the specification of a value.

➡ Select the colors to be displayed in the Signal Selection section.

The Comparison diagram shows the spectral progression in nanometers of the currently measured color and those of the taught colors from the color table.

The currently measured color (1) of the target is represented by the mixed color from the RGB color space.

The diagram display starts automatically. Use the `Stop` button

- to stop the diagram display,
- and to save in a CSV file (wavelength and reflectivity values) using the `Save` button.

i A color displayed on the monitor depends on the monitor settings.

5.7.2 Video Signal

Signal selection	Checkbox	The selection ranges from the raw signal of the array to the current spectrum which should be displayed in the diagram.
Exposure mode	Automatic Mode / Measurement Mode / Manual	A detailed description of the parameters can be found in the Measuring Rate chapter, see Chap. 5.3.4.
Measuring rate	Value	20.0 ... 2000.0 Hz
Control element	Start / Stop / Save	The diagram starts automatically with the call of the program.

➡ Change to the `Spectrum` program and select `Video signal`.

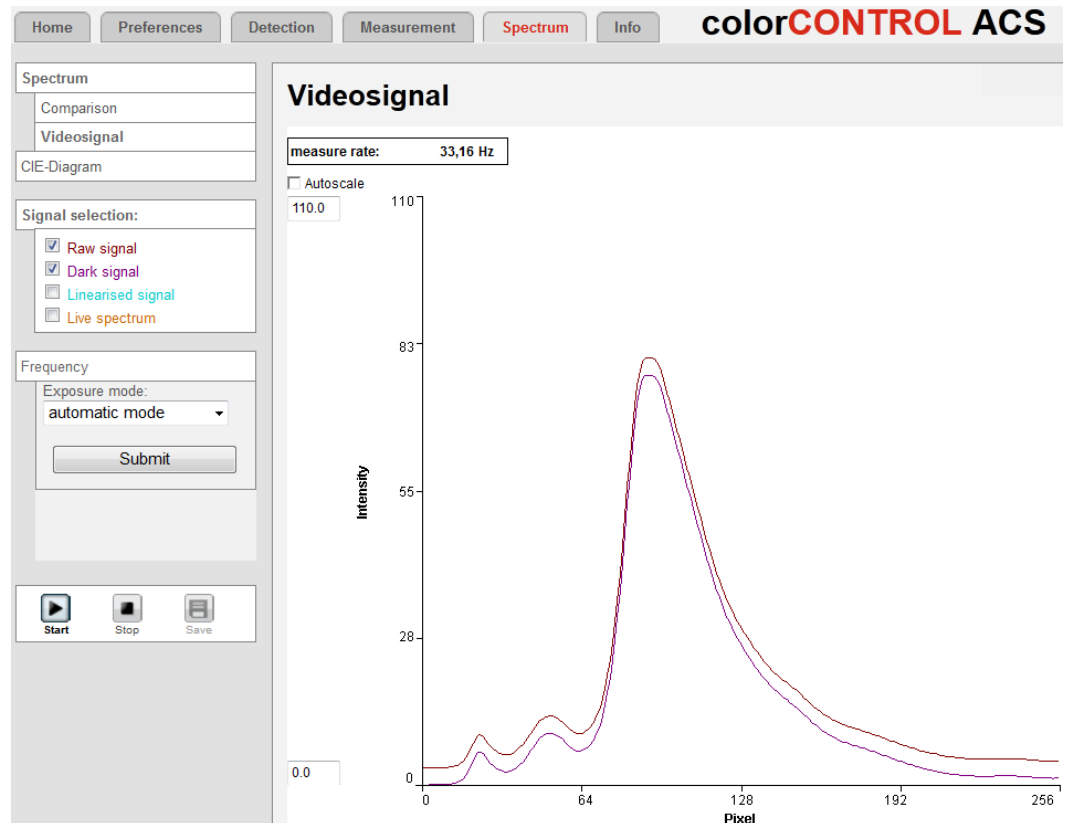

Fig. 45 Video Signal program

➡ Select the signals to be displayed in the `Signal Selection` section.

The `Video Signal` diagram shows the intensity (%) across the individual pixels of the array. The current measuring rate is shown above the diagram.

The diagram display starts automatically. Use the `Stop` button

- to stop the diagram display,
- and to save in a CSV file using the `Save` button.

5.7.3 CIE Diagram

Color space	L* a* b* / X Y Z / R G B / L* u* v* / L* C* h* / L* a* b*99 / L* C* h*99	Selection of the color space in which the measured values should be displayed.
Go to color database	Link	Link leads to the menu Preferences > Color table.
Teach color	Action button	Saves the currently measured color of the target in the color table. The color table comprises max. 16 colors.
Signal selection	Checkbox	Selection of available colors which should be shown in the diagram.
Control element	Start / Stop	The diagram starts automatically with the call of the program.

➔ Change to the Spectrum program and select CIE-Diagram.

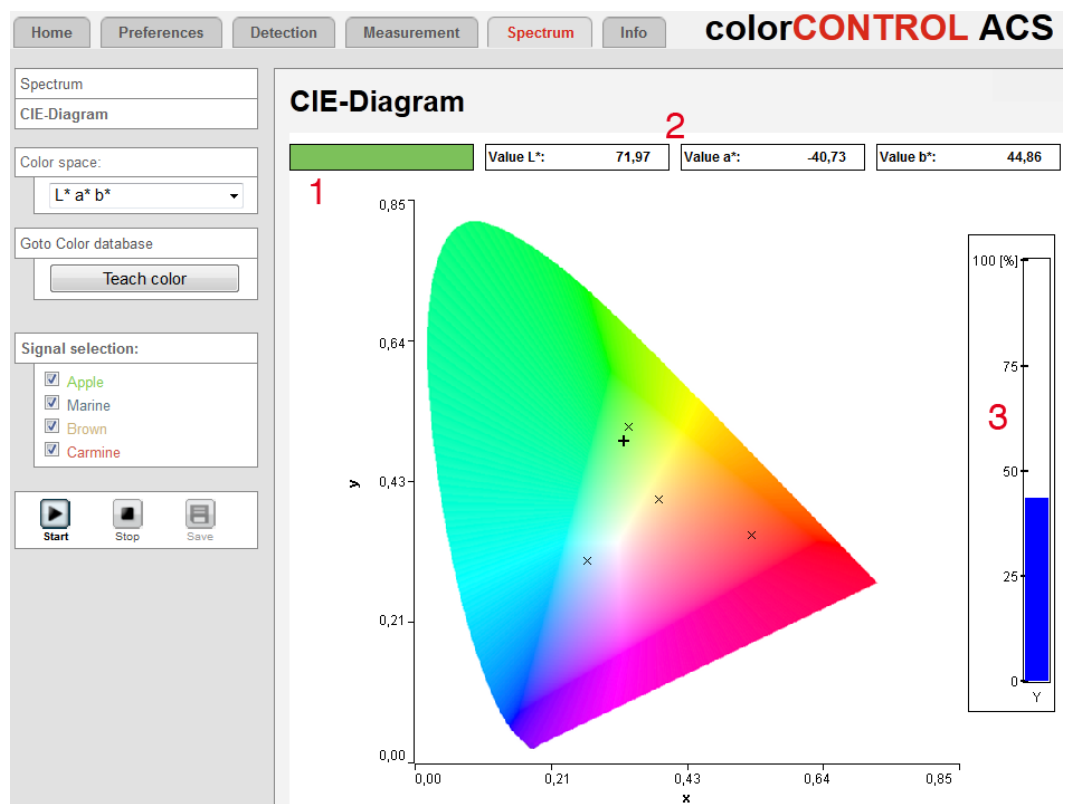

Fig. 46 CIE Diagram program

➔ Select the color space and the colors to be displayed in the Signal Selection section.

The diagram shows the position of the currently measured color (+) and all taught colors (x) in the CIE standard color chart, independently of the selected color space.

The bar graph (3) shows the current value of the Y color coordinate.

The currently measured color of the target is represented by the mixed color (1) from the RGB color space. The measured value boxes (2) show the individual color components for this in parallel.

The diagram display starts automatically. Use the Stop button to stop the diagram display.

Fields with a grey background require a selection.

Value
Dark bordered fields require the specification of a value.

! A color displayed on the monitor depends on the monitor settings.

5.8 Timing, Measurement Value Flux

The controller needs several cycles for measuring and processing:

1. Exposure: Charging the incoming light in the spectrometer/receiver,
2. Conversion of the video signal as digital values,
3. Calculation of color values, averaging
4. Color space transformations, color distance calculations, color recognition
5. Measurement value output.

The measured value N is provided at the output after three cycles.

As the processing is performed time-sequentially and space-parallel (levels), the next measured value (N+1) will already be output after a further cycle.

For example, at a measuring rate of 1 kHz, the cycle time is 1 ms; the delay time between input reaction and output signal for this measuring rate is 3 ms.

Cycle	1. (N)	2. (N+1)	3. (N+2)	4. (N+3)	5. (N+4)
Time	1 ms	2 ms	3 ms	4 ms	5 ms
1st Layer	Exposure N	Conversion N	Computing N	Computing N	Output N
2nd Layer	---	Exposure N+1	Conversion N+1	Computing N+1	Computing N+1
3rd Layer	---	---	Exposure N+2	Conversion N+2	Computing N+2
4rd Layer	---	---	---	Exposure N+3	Exposure N+3

Fig. 47 Controller timing after switching on, measuring rate 1 kHz

When triggering is active, the measured value output starts 3 cycles after the incoming trigger signal.

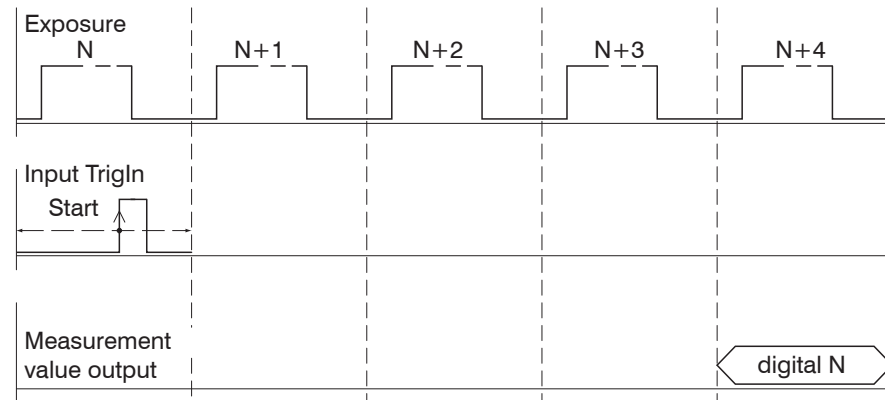

Fig. 48 Timing for triggering, rising edge, one measured value output

5.9 Reset to Factory Settings

- **i** Reset to factory settings is only possible in the Professional user level.

Button operation: Press and hold the buttons `Dark reference` and `Teach color` simultaneously for appr. 10 seconds.

Menu operation: Change to the menu `Preferences > Extras > Factory Settings`. Click the `Reset` button.

6. Warranty

All components of the device have been checked and tested for perfect function in the factory. In the unlikely event that errors should occur despite our thorough quality control, this should be reported immediately to MICRO-EPSILON Eltrotec.

The warranty period lasts 12 months following the day of shipment. Defective parts, except wear parts, will be repaired or replaced free of charge within this period if you return the device free of cost to MICRO-EPSILON Eltrotec. This warranty does not apply to damage resulting from abuse of the equipment and devices, from forceful handling or installation of the devices or from repair or modifications performed by third parties.

No other claims, except as warranted, are accepted. The terms of the purchasing contract apply in full. MICRO-EPSILON Eltrotec will specifically not be responsible for eventual consequential damages. MICRO-EPSILON Eltrotec always strives to supply the customers with the finest and most advanced equipment. Development and refinement is therefore performed continuously and the right to design changes without prior notice is accordingly reserved. For translations in other languages, the data and statements in the German language operation manual are to be taken as authoritative.

7. Service, Repair

In the case of a defect on the sensor or the sensor cable, please send the affected parts for repair or exchange.

In the case of faults whose causes are not clearly recognisable, please always send the complete measuring system.

MICRO-EPSILON Eltrotec GmbH
Manfred-Wörner-Straße 101
73037 Göppingen / Germany
Tel. +49 (0) 7161 / 98872-300
Fax +49 (0) 7161 / 98872-303
eltrotec@micro-epsilon.de
www.micro-epsilon.com

8. Decommissioning, Disposal

➡ Disconnect the power supply and output cable on the light source and receiver.

Incorrect disposal may cause harm to the environment.

Dispose of the device, its components and accessories, as well as the packaging materials in compliance with the applicable country-specific waste treatment and disposal regulations of the region of use.

Appendix

A 1 Optional Accessories

Art. no.	Description	Suitable for
11234274	Reflectance standard 1.25" Fluorilon	colorSENSOR and colorCONTROL
11234222	CAB-M9-4P-co-straight; 2m-PUR; open ends	colorCONTROL ACS7000 (power)
11234225	CAB-M9-4P-co-straight; 5m-PUR; open ends	colorCONTROL ACS7000 (power)
11234091	CAB-M9-8P-co-straight; 2m-PUR; open ends	colorCONTROL ACS7000 (digital I/O, Sync.)
11234099	CAB-M9-8P-co-straight; 5m-PUR; open ends	colorCONTROL ACS7000 (digital I/O, Sync.)
11234223	CAB-M9-7P-co-straight; 2m-PUR; open ends	colorCONTROL ACS7000 (colour Out)
11234226	CAB-M9-7P-co-straight; 5m-PUR; open ends	colorCONTROL ACS7000 (colour Out)
11294232	CAB-RJ45-Eth; 2m-PVC-Cat5e; RJ45-Eth	colorCONTROL ACS7000 (Ether-net/-CAT)
11293257	CAB-RJ45-Eth; 5m-PVC-Cat5e; RJ45-Eth	colorCONTROL ACS7000 (Ether-net/-CAT)
11294277	CAB-RJ45-Eth-Cross; 3m-PVC-Cat5e; RJ45-Eth	colorCONTROL ACS7000 (Ether-net/-CAT)
11293258	CAB-RJ45-Eth-Cross; 5m-PVC-Cat5e; RJ45-Eth	colorCONTROL ACS7000 (Ether-net/-CAT)
11234224	CAB-M9-5P-co-straight; 2m-PVC-RS422; open ends	colorCONTROL ACS7000 (RS422)
11234227	CAB-M9-5P-co-straight; 5m-PVC-RS422; open ends	colorCONTROL ACS7000 (RS422)
11234230	CAB-M9-5P-co-straight; 2m-PVC-RS422; Sub-D-15P-co-straight	colorCONTROL ACS7000 (IF2008)
11234231	CAB-M9-5P-co-straight; 5m-PVC-RS422; Sub-D-15P-co-straight	colorCONTROL ACS7000 (IF2008)
2213017	IF2008 Interface card RS422 / PCI-card	colorCONTROL ACS7000 (RS422/PC)
10824338	FCS-ACS1-30/0 adapter tactile	FCS-X-ACS1-30/0-50-XXXX
10824424	FCS-ACS adapter TT-TR	all ACS sensor heads (connection illumination into receiving fibres)
10824414	FCS-ACS3-200 mounting rail	FCS-X-ACS3
10824423	FCS-ACS3 mounting adapter 50mm	FCS-ACS3-200 mounting rail
10824422	FCS-ACS3 mounting adapter 150mm	FCS-ACS3-200 mounting rail
2420065	PS2030 power supply 24V/24W/ 1A; 2m-PVC; terminal-2P-co-fm-straight	CAB-M9-4P-co-straight; Xm-PUR; open ends (Power)

A 2 Factory Settings

Parameter Name	Value
User level after restart	Professional
Default password	000 Professional
IP address	169.254.168.150
RS422 interface parameters	8 data bits, no parity, one stop bit
Baud rate RS422	115.2 kBd
Light source	LED off / Passive mode
Exposure mode	Measurement mode
Measuring rate	250 Hz
Output data rate	N = 1, every measured value is transmitted
Triggering	none, controller starts transmitting data as soon as an output signal is configured and an interface is selected or through starting a diagram in the browser.
Synchronization mode	Master offline (standalone)
Primary interface used	Web diagram, ColorOut
Measurement program	Video / Spectrum
ColorOut	No output, switching outputs are off
Color database	Default data, deletes all taught colors
Video averaging	No video averaging
Measured value averaging	No measured value averaging
Minutes until automatic button lockout	5
Standard observer	10 °
Standard illuminat	D65
Distance model	Sphere (Euclidian)
ColorOut output mode	Binary
Operating mode after system start	Ethernet
Statistics, number of measured values for calculation	All values

A 3 ASCII Communication with Controller

A 3.1 General

All commands, inputs and error messages are in English. A command always consists of the command name and zero or more parameters, which are separated by spaces and are completed with LF. If spaces are used in parameters, the parameters must be placed in quotation marks (e.g. „password with spaces“).

Example:

```
Input:                ->MEASMODE COLORDETECTION
MEASMODE:            is the command name to select the measurement mode.
COLORDETECTION:     is the parameter for the command MEASMODE
```

The currently set parameter value is returned, if a command is activated without parameters.

The output format is:

```
<Command name> <Parameter1> [<Parameter2> [...]]
```

Example:

```
Input:                ->OUTCOLOR_ETH
Reply of system:     OUTCOLOR_ETH LAB LCH
```

In this case, optional parameters are returned only where necessary. For example, OUTCOLOR_ETH, will return enabled outputs only.

After processing a command, the system always returns a line break and a command prompt. In the event of an error, an error message starting with “Exx” will appear before the prompt, where xx represents a unique error number.

A 3.2 Commands Overview

Group	Chapter	Command	Short info
General			
		HELP	Help
		GETINFO	Controller information
		ECHO	Reply type
		PRINT	Overview parameters
User level			
		LOGIN	Change of user level
		LOGOUT	Change to user level
		GETUSERLEVEL	Request user level
		STDUSER	Set standard user
		PASSWD	Change password
Setup controller			
		OBSERVER	Viewing angle (standard observer)
		LOSRC	Light source mode (light type)
		LEDCTRL	Control of the light source
		LEDKW, LEDGR, LEDWW, LEDUV	Intensity of a LED quadrant
		AUTOLEDADJ	Starting a unique automatic adjustment of an internal LED
		DARKCORR	Start dark reference
		LIGHTCORR	Start light source reference

Interfaces			
		ETHERMODE	Ethernet- / EtherCAT-Modus
		IPCONFIG	Ethernet settings
		MEASTRANSFER	Set measurement server
		BAUDRATE	RS422 settings
		COLOROUT FORMAT	ColorOut setting
		BIN_FORMAT	Binary settings
		COMPARECOLOR	Select color to compare
Parameters, load/save settings			
		STORE	Save parameters
		READ	Load parameters
		SETDEFAULT	Set default setting
Color table			
		COLORTABLE	Color table
		COLORNEW	New color entry
		COLORDESCR	Adjusting a color description
		THRESHOLDS	Adjusting the limit values for color detection
		COLORSPACE	Selection of the color space for displaying values in the color table.
		MOVECOLOR	Moves color entries in the color table.
		RESETMAPPING	Reset the color mapping
		COLORDELETE	Delete color
Measurement			
		SHUTTERMODE	Exposure mode
		MEASRATE	Measuring rate
		DELTAMODE	Type of distance calculation
		DELTA_KL	Weighting factors to parameterize the measured color/material
		DELTA_KC	
		DELTA_KH	
Measurement value processing			
		VSAVERAGE	Video averaging
		AVERAGE	Averaging of measurement value
		STATISTICDEPTH	Values used for statistics
		RESETSTATISTIC	Reset the statistics
		OUTHOLD	Error processing

Data output			
		OUTPUT	Selection digital output
		MEASMODE	Depending on the measuring mode, different output data can be selected.
		OUTVIDEO	Selection of output data from the video section
		OUTCOLOR_ETH, OUTCOLOR_RS422	Selection of output data from the color measurement section, depending on the selected interface.
		DISTANCEMODE	Selection of colors, or Best Hit mode
		OUTDIST_ETH OUTDIST_RS422 OUTDIST_COLOROUT	Selection of output data from the color measurement section, depending on the selected interface.
		OUTSTATUS_ETH OUTSTATUS_RS422	Selection of output data from the status information section, depending on the selected interface.
		OUTSTATISTIC_ETH OUTSTATISTIC_RS422	Selection of output data from the statistics section, depending on the selected interface.
Hardware			
		GETVIDEO	Request video signal
		OUTREDUCE	Output data rate
		SYNC	Synchronization
		TRIGGER	Select trigger
		TRIGGERLEVEL	Select level active trigger input
		TRIGGERCOUNT	Number of measurements displayed
		TRIGGERSW	Software trigger pulse
		RESET	Booting the controller
		KEYLOCK	Key lock settings

A 3.3 General Commands

A 3.3.1 General

A 3.3.1.1 Help

```
HELP [<command>]
```

Help is displayed for a command. If no command is specified, general help information is displayed.

A 3.3.1.2 Controller Information

Sensor data are queried. Output as per example below:

```
->GETINFO
Name:          ACS_7000
Serial:        11100006
Option:        0
Article:       24500000
MAC-Address:   00:0C:12:01:09:00
Version:       007.045.169
Imagetype:     Factory
->
```

Name: Name of the controller model / controller series

Serial: Controller serial number

Option: Controller option number

Article: Controller article number

MAC Address: Network adapter address

Version: Version of the booted software

Image type: Type of the booted software (Factory- or User-Images)

The Factory Image is installed by the manufacturer of the controller and cannot be overwritten.

An update of User Images can be done by the end user. If an error occurs when updating the User Images, then the Factory Images is loaded when the system starts the next time.

A 3.3.1.3 Reply Type

```
ECHO ON|OFF
```

The reply type describes the structure of a command reply.

ECHO ON: The command name and the command reply or an error message is output.

ECHO OFF: Only the command reply or an error message is returned.

A 3.3.1.4 Parameter Overview

```
PRINT [ALL]
```

This command outputs a list of all setting parameters and its value.

A 3.3.2 User Level**A 3.3.2.1 Changing the User Level**

```
LOGIN <Password>
```

Enter the password to switch to a different user level. The following user levels exist:

- USER: Read-only access to all elements + use of the web diagrams
- PROFESSIONAL: Read/write access to all elements

Error	Description
E06	Access denied -> Incorrect password
E11	Password is too long (more than 31 characters)

A 3.3.2.2 Changing to User Level

```
LOGOUT
```

Sets the user level to USER.

A 3.3.2.3 Querying the User Level

```
GETUSERLEVEL
```

Request the current user level

For possible responses, see Chap. [A 3.3.2.1](#), “Changing the user level”.

A 3.3.2.4 Defining the Standard User

```
STDUSER USER|PROFESSIONAL
```

Sets the standard user, who is logged in after system start.

A 3.3.2.5 Changing the Password

```
PASSWD <Old Password> <New Password> <New Password>
```

Changes the password for the PROFESSIONAL level. The default (preset) password is “000”.

The old password must be entered once, and the new password twice. If the new passwords do not match, an error message is displayed. The password is case Sensitive and may contain only letters from A to Z without umlauts and numbers. The maximum length of the passwords is limited to 31 signs.

A 3.3.3 Sensor**A 3.3.3.1 Standard Observer and Standard Light Type**

OBSERVER TWO_DEGREE | TEN_DEGREE

LQSRC D65 | D50 | D75 | A | C | E | F4 | F7 | F11

The standard observer and illumination source specify the presumed observation characteristics for calculating the spectral color values. These correction parameters will then affect the color values, but not the measured spectrum.

A 3.3.3.2 Control of the Light Source

LEDCTRL [MAX | MIN | MANUAL | AUTO | OFF]

LEDKW | LEDGR | LEDWW | LEDUV <50 .. 1023>

Control of the illumination LED

- MAX: Maximum brightness on all quadrants
- MIN: Minimum brightness on all quadrants
- MANUAL: Control possibility on the single quadrants:
 - Cold-white (LEDKW),
 - Green (LEDGR),
 - Warm-white (LEDWW),
 - Violet (LEDUV)
- AUTO: Enables automatic configuration of optimum illumination. How to get started, see [A 3.3.3.3](#).
- OFF: Deactivates the illumination LED and switches the controller to the mode for measurement of light sources.

A 3.3.3.3 Automatic Light Source Adjustment

AUTOLEDADJ

Brightness of the illumination LED is adjusted once in the manual mode, using the optimum range for the selected manual measuring frequency.

Error	Description
E48	Automatic adjustment of the illumination LED can only be performed for manually specified frequencies.

A 3.3.3.4 Dark Reference

DARKCORR

Dark referencing eliminates the influence of the dark signal in the receiving array.

- Please make sure that no external light reaches the sensor during dark referencing.

The light source is switched off for the duration of the referencing process, and the dark signal of the array is received.

Error	Description
E04	Error with setting of internal parameters
E16	Timeout when dark reference
E18	A data transmitting is already running -> Dark reference not possible
E36	To much light input in the sensor. Object to light
E47	Large deviations were detected, please optimize measurement setup and repeat correction.

A 3.3.3.5 White Balance

LIGHTCORR

White balancing references the system against a white standard or a comparison light source.

During the process a white reference object is placed in front of the sensor at the specified measuring distance. Depending on the selected settings and the sensor used, white balancing may take up to one minute.

Do not change LED brightness settings after performing a white balance operation.

The manufacturer also performs a white balancing operation.

Perform a white balance operation for your own measurement setup. Repeat the white balance operation, if the measurement setup has been changed.

Error	Description
E04	Error with the setting of internal parameters (should never occur)
E16	Timeout when light correction
E18	A data transmitting is already running -> Light reference not possible
E37	To much light input in the sensor. Object to dark
E47	Large deviations were detected, please optimize measurement setup and repeat correction.

A 3.3.4 Interfaces**A 3.3.4.1 Ethernet- / EtherCAT Mode**

```
ETHERMODE ETHERNET|ETHERCAT
```

Configuration, in which the sensor should start after the booting.

Ethernet: Sensor starts in the Ethernet mode, web page is available.

EtherCAT: Data transmission via EtherCAT.

A 3.3.4.2 Ethernet IP Settings

```
IPCONFIG DHCP|STATIC [<IPAddress> [<Netmask> [<Gateway>]]]
```

Set Ethernet interface.

DHCP: IP address and gateway are automatically requested by DHCP. System looks for a LinkLocal address after appr. 2 minutes if no DHCP server is available.

STATIC: Set IP address, net mask, and gateway in format xxx.xxx.xxx.xxx

Values stay the same if no IP address, net mask, and gateway is typed in.

A 3.3.4.3 Ethernet Measurement Transmission Settings

```
MEASTRANSFER NONE|SERVER/TCP [<PORT>] | (CLIENT/TCP|CLIENT/UDP  
[<IPAdresse> [<Port>]])
```

For measurement transmissions via Ethernet the IFC24xx may be used as server or client.

- NONE: Measurements are not transmitted via Ethernet.
- SERVER/TCP: The controller provides a server at the specified port through which measurement values can be retrieved. This is possible only with TCP/IP.
- CLIENT/TCP: The controller sends measurement values to the specified server via TCP/IP, depending on the connection type. IP address and server port must be specified, see Chap. [A 3.6.1](#).
- CLIENT/UDP: The controller wirelessly sends measurement values to the specified server via UDP/IP. IP address and server port must be specified.
- IP address: The IP address of the server that the measurements are sent to during client mode (may only be specified for CLIENT/TCP or CLIENT/UDP).
- Port: Port to which the server is connected in server mode or to which measurement values are transmitted in client mode (min: 1024, max: 65535).

A 3.3.4.4 Setting RS422 Baud Rate

```
BAUDRATE <Baudrate>
```

Used baud rates of the serial RS422 interface in Bps: 9600, 115200, 230400, 460800, 691200, 921600, 1500000, 2000000, 3500000

A 3.3.4.5 ColorOut Setting (Digital Out)

```
COLOROUT_FORMAT (<NONE>|<BINARY>|<CHANNEL>|<LAB-CHECK>)
```

- <BINARY>: 15 colors can be signalled via the color out using binary code.
- <CHANNEL>: In this mode, each of the 4 maximum available colors is assigned an exclusive out pin for the color out.
If a color is recognized, a signal is transmitted via the corresponding channel. Currently the first 4 colors of the color table are used.
- <LAB-CHECK>: In this mode, all color out channels are assigned to a selected color. If L*, a* or b* is within the respective tolerance thresholds, one channel will send a corresponding signal.
Choose "Data selection" in Selection mode to select multiple colors for analysis. If multiple colors are selected or best hit mode is enabled, the system automatically determines the color with the lowest color difference and then checks each difference.

A 3.3.4.6 Set Binary Format

`BIN_FORMAT MSB | LSB`

MSB: Pin 4 is set, if color 1 was detected (color 1 corresponds to 1000)

LSB: Pin 1 is set, if color 1 was detected (color 1 corresponds to 0001)

A 3.3.4.7 Select a Color in the L*a*b*-Check Mode

`COMPARECOLOR <Number>`

Selects a color in the L*a*b*-check mode.

- Number: color number from the color table

A 3.3.5 Parameter Management, Load / Save Settings

A 3.3.5.1 Save Parameter

`STORE 1|2|3|4|5|6|7|8`

Save the current parameter under the specified number in the flash.

A 3.3.5.2 Load Parameter

`READ ALL|DEVICE|MEAS 1|2|3|4|5|6|7|8`

Load the parameter under the specified number from the flash.

In addition, the size of the loaded data needs to be specified:

- ALL: All parameters are loaded.
- DEVICE: Only the standard device settings are loaded (interface parameter)
- MEAS: Only the measurement settings are loaded (all features for the measurement).

A 3.3.5.3 Default Settings

`SETDEFAULT ALL|CURRENT|COLOR <KEEPDEV> <SAVE>`

Set the default values (Reset to default setting).

- ALL: In addition, the current material table is overwritten by standard material table.
- KEEPDEV: All setups are deleted and default parameters are loaded. Settings for Ethernet/EtherCAT, of IP address, language and RS422 are kept temporarily.
- COLOR: Only color table is reset to the standard color table.
- CURRENT: The current setup is reset to the factory setting.
- SAVE: Stores the temporarily settings in a setup.

A 3.4 Color Database

A 3.4.1 Color Table

COLORTABLE

ASCII codes are used to issue a table with currently known (learned) system colors to retrieve an overview of the current color database.

```
->COLORTABLE
+---+-----+-----+-----+-----+-----+-----+-----+
|No| Color  |Observer |Illuminant|L*      |a*      |b*      |Spectrum |
+---+-----+-----+-----+-----+-----+-----+-----+
| 1| Red    | 2 Grad  | D65      | 30.894 | 65.584 | 53.251 |available|
| 2| Green  | 2 Grad  | D65      | 75.229 | -75.076| 47.377 |available|
| 3| Blue   | 2 Grad  | D65      | 50.426 | -22.511| -53.799|available|
+---+-----+-----+-----+-----+-----+-----+-----+
->
```

A 3.4.1.1 Teaching New Color

```
COLORNEW <location no.> <name> <lab|XYZ|spectrum> <observer>
<illuminant> (<L*><a*><b*>) | (<X><Y><Z>)
```

Add or edit a color

- Name: Color name. Length: max. 15 characters, no special characters or umlauts.
- Description: Color description. Length: max. 63 characters, no special characters or umlauts.
- Color space:
 - For lab & XYZ all values must be entered manually.
 - For the spectrum, the object in front of the sensor is measured automatically using the system data, and the resulting values are stored in the database.

The database contains a maximum of 16 color entries, but only 15 may be signalled via ColorOut.

Example:

```
COLORNEW <location no.> <name> <color space> <observer> <illuminant> <X>
<Y> <Z>
```

```
->colornew 12 "Green" XYZ 2 D65 35.760 71.520 11.920
COLORNEW OK
->
```

Or via the spectrum:

```
COLORNEW <location no.> <name> <color space>
```

```
->colornew 5 Green Spectrum
COLORNEW OK
->
```

A 3.4.1.2 Adjusting a Color Description

```
COLORDESCR <color name> "description"
```

Use the COLORDESCR feature to add a description for a color.

The <color name> parameter is case-sensitive, please use lower and upper case accordingly.

Display the description

```
->colordescr "Green 168"
LEE FLUORESCENT 3600 K
->
```

Edit/add a description

```
->colordescr color "Green 168"
COLORDESCR OK
->
```

A 3.4.1.3 Threshold Values Based on the Mode of Calculation

```
THRESHOLDS <color name> <DELTA_E_L> <DELTA_A_AB> <DELTA_B>
```

Determines a color's tolerance value. If the currently measured color is within the thresholds, it is issued or displayed as recognized.

At least one distance value must be provided instead of the <DELTA_E_L> <DELTA_A_AB> <DELTA_B> parameters. The number of parameters that are used for distance calculations depend on the selected type of color difference calculation.

The <color name> parameter is case-sensitive, please use lower and upper case accordingly.

Color difference mode DELTA <SPHERE> (Euclidean distance) uses only DELTA_E_L as ΔL^* to determine threshold values. No other tolerance values are taken into account.

Color difference mode DELTA <CYLINDER> uses only DELTA_E_L as ΔL^* , and DELTA_A_AB as Δa^*b^* , to determine threshold values. No other tolerance values are taken into account.

Color difference mode <BOX> uses DELTA_E_L as ΔL^* , DELTA_A_AB as Δa^* and DELTA_B as Δb^* to determine threshold values.

Example for retrieving a color's threshold values:

```
->thresholds "Green 165"
THRESHOLDS Green 165 1.0000000 1.0000000 1.0000000
->
```

Example for specifying and then checking a color's threshold values:

```
->thresholds "Green 165" 0.756 0.256 0.456
THRESHOLDS OK
->thresholds "Green 165"
THRESHOLDS Green 165 0.7560000 0.2560000 0.4560000
->
```

i To permanently store threshold values so that they are maintained even after re-starting the controller, you need to store them as part of a setup configuration.

A 3.4.1.4 Switching the Display of Color Space Data (XYZ or L*a*b*)

```
COLORSPACE [<XYZ> | <LAB>]
```

The way color coordinates are displayed in the color table can be specified through the color space (XYZ or L*a*b*).

The color table display is adjusted depending on which color space is selected. This parameter only changes the display in the color table, it does not affect measurement values.

A 3.4.1.5 Moving Color Entries in the Table

```
MOVECOLOR <current color position> <new color position>
```

Use MOVECOLOR to move color entries within the color table.

Moving a color means that a recognized color can be signalled via different out pins of the ColorOut switching output (in line with ColorOut modes).

Any emerging gaps are filled with the next or previous colors.

Move a color entry:

```
->colortable
+---+-----+-----+-----+-----+-----+-----+-----+
|No| Color  | Observer | Illuminant| X      | Y      | Z      | Spectrum|
+---+-----+-----+-----+-----+-----+-----+-----+
| 1| Red    | 2 Grad  | D65      | 7.730 | 4.041 | 0.407 | available|
| 2| Green  | 2 Grad  | D65      | 19.419| 38.420| 15.445| available|
| 3| Blue   | 2 Grad  | D65      | 7.109 | 9.438 | 33.333| available|
+---+-----+-----+-----+-----+-----+-----+
->movecolor 1 3
->colortable
+---+-----+-----+-----+-----+-----+-----+-----+
|No| Color  | Observer | Illuminant| X      | Y      | Z      | Spectrum|
+---+-----+-----+-----+-----+-----+-----+-----+
| 1| Green  | 2 Grad  | D65      | 19.419| 38.420| 15.445| available|
| 2| Blue   | 2 Grad  | D65      | 7.109 | 9.438 | 33.333| available|
| 3| Red    | 2 Grad  | D65      | 7.730 | 4.041 | 0.407 | available|
+---+-----+-----+-----+-----+-----+-----+-----+

```

A 3.4.1.6 Resetting any Color Shifts

```
RESETMAPPING
```

Use RESETMAPPING to reset any color entries to their teach position, where a color entry is directly related to its position in the flash memory.

A 3.4.1.7 Deleting Color

```
COLORDELETE <Name>
```

Deletes a color

- <Name>: Name of the color to be deleted (length: max. 16 characters)

A 3.5 Measurements

A 3.5.1 General

A 3.5.1.1 Type of Color Difference Calculation (Sphere, Cylinder, Box)

```
DELTAMODE <EUKLID | CYLINDER | BOX | DIN99 | CMC | CIE94 |
CIEDE2000 >
```

Switches between the different methods of color difference calculation.

- EUKLID: Sphere, Euclidean distance, results: ΔE
- CYLINDER: Cylindrical distance, results: ΔL^* , Δa^*b^*
- BOX: Box distance calculation, results: ΔL^* , Δa^* , Δb^*
- DIN99: Abstand nach DIN99
- CIE94: Abstand nach CIE94
- CMC: Abstand nach CMC
- CIEDE2000: Abstand nach CIEDE2000

A 3.5.1.2 Exposure Mode

```
SHUTTERMODE <SEARCH | MEAS | MANUAL>
```

- SEARCH: Automatic mode (to determine the best exposure time and measurement rate)
- MEAS: Measurement mode (exposure time control at a fixed measurement rate; recommended for measurements)
- MANUAL: Manual mode (user can select fixed exposure time and measurement rate)

A 3.5.1.3 Parameter Color Difference Calculation

- DELTA_KL 0.0 .. 3.0
- DELTA_KC 0.0 .. 3.0
- DELTA_KH 0.0 .. 3.0

The weighting factors precisely describe the measured colors / materials for the color calculation. These parameters are incorporated in the calculation for the following standards CIE94, CMC and CIEDE2000.

A 3.5.1.4 Measuring Rate

```
MEASRATE [20..2000]
```

Selects the measuring rate in kHz.

No more than one decimal place may be specified.

A 3.5.2 Measurement Value Processing

A 3.5.2.1 Video Averaging

```
VSAVERAGE <NONE|REC2|REC4|REC8|REC16|REC32|REC64|REC128>
```

- NONE: No averaging of the video signals
- RECxxx: Recursive average over x video signals

A 3.5.2.2 Averaging of Measurement Value (via Software)

```
AVERAGE <NONE|MOVING|RECURSIVE|MEDIAN> [<Averaging depth>]
```

The averaging value always affects all to be output displacement and difference values.

- NONE: No averaging value
- MOVING: Moving averaging value (averaging depth 2, 4, 8, 16, 32, 64 up to 1024 possible)
- RECURSIVE: Recursive averaging value (averaging depth 2 up to 32768 possible)
- MEDIAN: Median (averaging depth 3, 5, 7 and 9 possible)

A 3.5.2.3 Setting the Statistics Calculation

```
STATISTICDEPTH ALL|2|4|8|...|8192|16384
```

Input on how many measurement values the statistics data minimum, maximum and peak-to-peak are determined.

A 3.5.2.4 Reset the Statistics Calculation

```
RESETSTATISTIC
```

Reset the statistics (of the current min and max value).

A 3.5.2.5 Error Processing

```
OUTHOLD NONE|0|<Number>
```

Setting the behavior of the measurement value output in case of error.

- NONE: No holding the last measurement value, output of error value
- 0: Infinite holding of the last measurement value
- Number: Holding the last measurement value on the number of measuring cycles; then an error value (maximum of 1024) is output.

A 3.6 Data Output

The possible combinations and number of output measurements will vary according to the selected interface, as well as the output mode.

A 3.6.1 Selection Digital Output

```
OUTPUT NONE|RS422|ETHERNET|ETHERCAT
```

- NONE: No measurement value output
- RS422: Output of measurement values via RS422
- ETHERNET: Output of measurement values via Ethernet
- EtherCAT: Measurement output via EtherCAT, if the controller operates in EtherCAT mode only

A 3.6.2 Measuring Mode

```
MEASMODE <COLORMEASURE | COLORDETECTION | VIDEOSPECTRUM>
```

- COLORMEASURE: Used to issue measured color values in different color spaces and system measurement values.
- COLORDETECTION: The difference between the currently measured color and a number of learned colors is used to perform color detection. All color differences for the selected colors can be issued via Ethernet. Use RS422 to always issue the color with the smallest color difference (provided it is within the specified thresholds) in addition to optional current measurement values.
- VIDEOSPECTRUM: Video image transmission – active video data or the calculated spectrum are transmitted plus optional system measurement values. Video images must be requested individually using the corresponding command.

Transmission of recognized colors via the ColorOut switching output may be configured and started independently of the primary output interface using the relevant command.

A 3.6.3 Select Measurement Values to be Output

Setting the values to be output via the RS422 and Ethernet interface.

Maximum 32 measurement values are transmitted with RS422 in parallel.

The maximum output rate via the Ethernet interface depends on the number of output values.

Use the Ethernet interface to issue each selected color in its relevant color difference mode, while RS422 will transmit only the color with the smallest difference to the currently measured color.

If you want to select only signals from individual sections, the following independent subgroups apply.

A 3.6.3.1 Output Mode: Video/Spectrum

The following signals may be selected in Video/Spectrum mode:

- Issuing video signals

```
OUTVIDEO NONE | ([RAW] [DARK] [LIN] [LIGHT])
```

Configures data to be sent during the transmission of video signals.

- NONE: No video signals
- RAW: Issues the raw signal
- DARK: Issues the signal after dark correction
- LIN: Issues the linearized signal
- LIGHT: Issues the spectrum (signal against the white reference)

Video signals may only be transmitted via Ethernet.

A 3.6.3.2 Output Mode: Color Measurement

The following signals may be selected in Color Measurement mode:

```
OUTCOLOR_ETH NONE | ([XYZ] [RGB] [LAB] [LUV] [LCH] [LAB99] [LCH99])
```

```
OUTCOLOR_RS422 NONE | ([XYZ] [RGB] [LAB] [LUV] [LCH] [LAB99] [LCH99])
```

Each calculated color in one of the available color spaces is associated with three measurement values. For example, if you select `OUTCOLOR_RS422 [LAB]`, three measurement values (L* value, a* value, b* value) are transmitted via the serial interface.

A 3.6.3.3 Output Mode: Color Recognition

```
DISTANCEMODE [BESTHIT] | [SELECTION]
```

Depending on which mode of color difference calculation is selected, the `BESTHIT` mode issues the difference(s) for the color with the lowest difference to the current measurement value. All colors in the color table are evaluated to calculate the lowest difference.

For Ethernet transmission only, `SELECTION` mode enables the user to select colors from the table for which the difference may be calculated and issued individually.

The following signals may be selected in Color Recognition mode:

```
OUTCOLOR_ETH NONE | [LAB]
OUTCOLOR_RS422 NONE | [LAB]
OUTDIST_ETH NONE | ([DETECTCOLORID] [NEARCOLORID] [MINDISTANCE]
[DIST01] [DIST02] ... [DIST16])
OUTDIST_RS422 NONE | ([DETECTCOLORID] [NEARCOLORID] [MINDISTANCE])
OUTDIST_COLOROUT NONE | [DETECTEDCOLORID]
```

If `OUTDIST_ETH` is used, any colors to be included in the calculation/output need to be passed one by one as parameters via `DISTxx`.

This example shows how to issue the number of the detected color and the distances to the first three (learned) colors in the color table.

```
->outdist_eth detectedcolorID dist01 dist02 dist03
OUTDIST_ETH OK
->
```

A 3.6.3.4 Output Hardware Status Values

```
OUTSTATUS_ETH NONE | [FRAMERATE] [SHUTTERTIME] [TEMP_VIDEO]
[TEMP_LQ] [COUNTER] [TIMESTAMP] [ERROR] LM_RED] [LM_GREEN] [LM_
BLUE] [LM_BRIGHT]
```

```
OUTSTATUS_RS422 NONE | [FRAMERATE] [SHUTTERTIME] [TEMP_VIDEO]
[TEMP_LQ] [COUNTER] [TIMESTAMP] [ERROR] [LM_RED] [LM_GREEN] [LM_
BLUE] [LM_BRIGHT]
```

Configures data to be sent during the transmission of video signals.

- `NONE`: No illuminant measurement values are issued
- `TEMP_VIDEO`: Issues the current temperature of the video array
- `FRAMERATE`: Issues the current output rate (measuring frequency)
- `SHUTTERTIME`: Issues the current exposure time
- `TEMP_LQ`: Issues the current temperature of the illuminant
- `COUNTER`: Issues the profile counter
- `TIMESTAMP`: Issues a time stamp
- `ERROR`: Issues any error codes
- `LM_RED`: Illuminant intensity is issued for the following area: Red
- `LM_GREEN`: Illuminant intensity is issued for the following area: Green
- `LM_BLUE`: Illuminant intensity is issued for the following area: Blue
- `LM_BRIGHT`: Issues the total intensity of the illuminant

The value range for the color intensity of the illuminant is [0 .. 65536].

A 3.6.3.5 Output of Statistics through RS422 and Ethernet

The command `OUTSTATISTIC_x` is used to select the statistic values to be output.

```
OUTSTATISTIC_ETH NONE | ([MIN] [MAX] [PEAK2PEAK])
OUTSTATISTIC_RE422 NONE | ([MIN] [MAX] [PEAK2PEAK])
```

Since the statistic is expected to be led by a valid signal, make sure that such a signal has been chosen in the measuring mode when outputting statistic values.

A 3.6.3.6 Signal Selection for Statistics

The command `STATISTICSIGNAL`, is used to select the signal performing statistics.

```
STATISTICSIGNAL NONE | ([XYZ] [RGB] [LAB] [LUV] [LCH] [LAB99]
[LCH99] [ERROR] [DIST01] [DIST02] .. [DIST16] [MINDIST] [DETEC-
TID] [MINDISTID])
```

Example: Output of signal XYZ and the corresponding statistics (Min, Max, P2P) through Ethernet.

```
STATISTICSIGNAL XYZ
```

The kind of statistics must be selected through

- `OUTCOLOR_ETH XYZ`
- `OUTSTATUS_ETH MIN MAX PEAK2PEAK`

as well as the real signal used for statistics.

A 3.7 Hardware

A 3.7.1 Video Signal Request

```
GETVIDEO
```

Request of video signal via Ethernet interface.

A 3.7.2 Output Data Rate

```
OUTREDUCE <Output reduction> [NONE|RS422|ETHERNET|ALL]
```

Reduces the measurement value output for the selected interfaces.

- 1: Output each measurement value
- 2...1000: Output of each n-th measurement value

A 3.7.3 Synchronization

```
SYNC NONE|MASTER|SLAVE
```

Setting the type of synchronization:

- NONE: No synchronization
- MASTER: The controller is master, ie. it transmits synchronization pulses
- SLAVE: The controller is slave and receives synchronous pulses from another controller

Sync may be an input or output, so you need to ensure that one of the controllers is defined as a master and the other one as a slave.

The sync input is also used as trigger input for flank and level triggering (see Chap. Triggering).

Error	Description
E02	Incorrect parameter type (not a valid type of synchronization).
E11	Parameter 1 is too long.

A 3.7.4 Trigger Modes

Trigger-input serves also as synchronous input, which means level and edge triggering is only alternatively possible to sync mode.

A 3.7.4.1 Trigger Type

TRIGGER NONE|EDGE|PULSE|SOFTWARE

- NONE: No triggering
- PULSE: Level triggering
- EDGE: Edge triggering
- SOFTWARE: Software triggering

A 3.7.4.2 Trigger Level

TRIGGERLEVEL HIGH|LOW

- HIGH: Edge triggering: Rising edge, level triggering: High-active
- LOW: Edge triggering: Falling edge, level triggering: Low-active

A 3.7.4.3 Number of Output Measurement Values

TRIGGERCOUNT <1 .. 16382>|16383

Number of measurement values which are displayed after a trigger impulse when edge triggering or software triggering.

- 1...16382: Number of measurement values which are displayed after a trigger impulse when edge triggering or software triggering.
- 16383: Start infinite output of measurement values after a trigger impulse when edge triggering or software triggering.
- 0: Stop triggering

A 3.7.4.4 Software Trigger Pulse

TRIGGERSW

Creates a software trigger pulse

Error	Description
E43	The controller is not in the software trigger mode

A 3.7.5 Booting the Controller

RESET

The Controller restarts.

A 3.7.6 Keylock

KEYLOCK INACTIVE | ACTIVE | AUTO <TIME>

Configures the keylock. Enter a time in minutes in automatic mode to start the keylock.

A 3.8 Measured Value Format

This Chapter describes the assembly of measured value frames. Informations to transfer via Ethernet or RS422 succeed, see Chap. [A 3.9](#).

The data block has a fixed structure (sequence):

- Video signals (128 / 256 / 384 / 512 x 32 Bit)
- Frequency (2 x 32 Bit)
- Temperature of the array (1 x 32 Bit)
- Temperature of the light source (4 x 32 Bit)
- Intensity sensor light source (1 x 32 Bit)
- Counter (1 x 32 Bit)
- Time stamp (1 x 32 Bit)
- Color measurements (n x 3 x 32 Bit; n: number of selected color spaces)
- Error status (1 x 32 Bit)
- Color distance (m * i * 32 Bit)
- Statistic (i * 32Bit)

m = {1 ..16} number of selected color distances

i = {1, 2, 3} number of data blocks per color (1: Euklidisch, 2: Zylinder, 3: Box)

-> i * 32 Bit, Bit 0..13 color distance (11,10)

Possible color measurements:

- XYZ, RGB: 8 Bit in front of the decimal point, 10 Bit decimal places
- L*a*b*, L*u*v*, L*c*h*: 9 Bit in front of the decimal point, 10 Bit decimal places

The dynamic measurement frame transmits selected values only, see Chap. [A 3.6.3](#).

A 3.8.1 Video Signal

Video signals can be transmitted that have been calculated during signal processing. Each video signal consists of 256 pixels. Each pixel is described by a 16 bit word. The relevant value range is 0...16383.

The following available video signals exist:

- Raw signal
- Dark corrected signal
- Linearized signal
- Balanced signal (spectrum)

Video signal data structure:

Pixel 0	Pixel 2	...	Pixel 255
Raw signal, 16 bit	Raw signal, 16 bit		Raw signal, 16 bit
Dark corrected signal, 16 bit
Linearized signal, 16 bit	Balanced signal	...	Balanced signal
Balanced signal (spectrum), 16 bit	(spectrum), 16 bit		(spectrum), 16 bit

A 3.8.2 Exposure Time / Frequency

The image frequency provides the actual processing frequency per image. This has to be translated: real image frequency in kHz = $10^6 / (\text{frequency} * 12.5 \text{ ns})$

Bit 28 and 29:

- 00 no special event
- 01 maximum frequency
- 10 hysteresis area
- 11 minimum frequency

The exposure time is shown in digits (exposure time * 12.5 ns) = true exposure time on which the line was illuminated.

A 3.8.3 Array Temperature

The array temperature is output with 10 Bit. The temperature range is -128 °C up to 127,75 °C. This results in a resolution of about 0.25 ° C.

A 3.8.4 Light Source Temperature

The light source temperature is output with 10 Bit. The temperature range is -128 °C up to 127,75 °C. This results in a resolution of about 0.25 ° C.

A 3.8.5 Measurements of the Light Source

The block provides the color and intensity values of the internal color sensor. The raw data are output with 16 Bit.

A 3.8.6 Measured Value Counter

The transmission of the measured value counter via Ethernet is effected as 32 bit value (unsigned integer).

On the RS422 interface, only the lower 18 bits of the profile counter are transmitted.

A 3.8.7 Time Stamp

The time stamp is transmitted as 32 bit value. The resolution is 1 µs.

During transmission via RS422 only the bits 25 up to 8 of the time stamp are transmitted. It follows a resolution of 0.25 ms.

A 3.8.8 Color Measurement Data

Depending on the color space, different codes are used:

- XYZ and RGB: 3 x 32 Bit data words (8 Bit pre-decimal point position, 10 Bit decimal places, unsigned)
- other color spaces: 3 x 32 Bit data words (9 Bit pre-decimal point position, 10 Bit decimal places, signed)

XYZ and RGB: 3 x 32 bit

Bit position	Description
0 - 17	X/Y/Z resp. RGB value, unsigned, 8 Bit pre-decimal point, 10 Bit decimal places
18 - 31	Reserved

L*a*b* & L*u*v* & L*c*h*: 3 x 32 bit

Bit position	Description
0 - 18	L*/a*/b*/u*/v*/c*, -value, signed, 9 Bit pre-decimal point, 10 Bit decimal places H° acc. to CIE & DIN99 are unsigned values (0 up to 360 degrees)
19 - 31	Reserved

A 3.8.9 Color Difference Values

The following methods may be used to calculate the color difference:

- Euclidean (ΔE), 1 measurement value per color
- Cylinder (ΔL^* , Δa^*b^*), 2 measurement values per color
- Box (ΔL^* , Δa^* , Δb^*), 3 measurement values per color

Depending on the color difference calculation mode, different numbers of data packages per color are issued after selecting a color.

Furthermore the command DELTAMODE can be used to select the specification how the color distance should be calculated. The choices are:

- Euclidean,
- DIN99,
- CIE94,
- CMC
- CIEDE2000

The object to be measured could be described in more detail by the weighting factors k_L , k_C and k_H .

The distance values are transmitted as 32 Bit signed integers. The distance value contains 11 Bit pre-decimal point position and 10 Bit decimal places.

To remain compliant with the 18 Bit payload restriction for RS422 interfaces, the distance values are transmitted as follows even via Ethernet: color distance via RS422 (11 Bit pre-decimal point position and 7 Bit decimal places). The ColorID can be ordered separately.

A 3.8.10 Error Status

Only the upper 16 bits of the error are transferred during RS422 transmission.

Bit position	Category	Description
0	Error in color space transformation	Error with the Lch99 calculation
1		Error with the Lch calculation
2		Error with the Luv calculation
3		Error with the Lab calculation
4		Error with the RGB calculation
5		Reserved
6	Internal error	Synchronization error
7		Too much light – detector (raw signal) is in saturation
8		Insufficient light – detector (raw signal) - limit of automatic control
9		Reserved
10	External error	Error at the output drivers -> Switching off the outputs
11		Temperature of the detector is greater than 70 °C, LED is turned off
12		Temperature of the light source is greater than 70 °C, LED is turned off
13		Reserved
14	Trigger	Reserved
15		Triggered output
16	IO status	State of the synchronous output
17		Color output pin 1
18		Color output pin 2
19		Color output pin 3
20		Color output pin 4
21		Error output
22	LED status	Dark reference
23		Dark reference
24		White reference
25		White reference
26		Teach color
27		Teach color
28		Status (system is ready for measurement)
29		Status (system is ready for measurement)
30		Measuring done (measurement in progress)
31		Measuring done (measurement in progress)

A 3.8.11 Statistics Values

The statistical values have the same format as the color differences.

If selected, the minimum value is transmitted first, followed by the maximum and then Peak-to-Peak.

Statistics values are displayed as 32-bit signed integers or in the relevant RS422 interface format.

A 3.9 Measurement Data Format

A 3.9.1 RS422 Interface

18-bit unsigned raw values are issued, and up to 32 measurement values may be transmitted.

Measurement 1:

	Preamble		Data bits					
L-byte	0	0	D5	D4	D3	D2	D1	D0
M-byte	0	1	D11	D10	D9	D8	D7	D6
H-byte	1	0	D17	D16	D15	D14	D13	D12

Measurement 2 ... 32:

	Preamble		Data bits					
L-byte	0	0	D5	D4	D3	D2	D1	D0
M-byte	0	1	D11	D10	D9	D8	D7	D6
H-byte	1	1	D17	D16	D15	D14	D13	D12

Value range for color difference and color measurements:

Any values greater than 262072 are error values and are defined as follows:

Error code	Description
262073	Scaling error, RS422 interface, underflow
262074	Scaling error, RS422 interface, overflow
262075	Amount of data too big for baud rate ¹⁾

For all other data outputs, apart from measurement data, restrictions are defined in the relevant sections, see Chap. [A 3.7](#).

1) This error occurs if more data are selected for issuing than can be transmitted at the selected baud rate and measuring frequency. There are several ways to solve this error:

- Increase baud rate, see Chap. [A 3.3.4.4](#)
- Reduce measuring frequency, see Chap. [A 3.5.1.4](#), see Chap. [5.3.4](#)
- Reduce the amount of data, or reduce to one data word if 2 were selected, see Chap. [A 3.6.3](#)
- Reduce output data rate, see Chap. [A 3.7.2](#)

Group	Name	Index	RS422					
			Raw		Scaled			
			Min	Max	Min	Max	Formula	Unit
Status	Framerate	1	2500	250000	20.00	2000.00	$10^6 / (x * 12.5 * 2^4) * 1000$	Hz
	Shutter	2	2500	250000	20.00	2000.00	$x * 12.5 * 2^4 / 10^9$	μs
	TempDetector	3	-1024	1023	-256.00	255.75	x/4	°C
	TempLightSrc	4	-1024	1023	-256.00	255.75	x/4	°C
Light-Sensor	Red	5	0	65535	0.00	100.00	$x / 65536 * 100$	%
	Green	6	0	65535	0.00	100.00	$x / 65536 * 100$	%
	Blue	7	0	65535	0.00	100.00	$x / 65536 * 100$	%
	Brightness	8	0	65535	0.00	100.00	$x / 65536 * 100$	%
Status	Counter	9	0	262143	0	262143	x	-
	Timestamp	10	0	262143	0.00	67.11	$x * 256 / 100000$	s
Color	XYZ	11-13	0	131072	0.00	256.00	$x / 512$	-
	RGB	14-16	0	131072	0.00	256.00	$x / 512$	-
	LAB	17-19	-131072	131071	-256.00	256.00	$x / 512$	-
	LUV	20-22	-131072	131071	-256.00	256.00	$x / 512$	-
	LCH (L/C)	23-24	-131072	131071	-256.00	256.00	$x / 512$	-
	LCH (H)	25	0	131071	0.00	256.00	$x / 512$	°
	LAB99	26-28	-131072	131071	-256.00	256.00	$x / 512$	-
	LCH99 (L/C)	29-30	-131072	131071	-256.00	256.00	$x / 512$	-
	LCH99 (H)	31	0	184320	0.00	360.00	$x / 512$	°
Status	Error	32	0	262143	0	262143	x	-
Distance	1_1/2/3	33-35	NA	-				
	...	36-77						
	16_1/2/3	78-80		-				
	Min_1/2/3	81-83	-131072	131071	-256.00	256.00	$x / 512$	-
	DetectedID	84	0	16	0	16	-	-
	MinDistID	85	0	16	0	16	-	-

Fig. 49 Overview of output data via RS422

Calculation specifications for a L*a*b* measurement transferred via RS422:

Data word	23 6E C3 1A 59 C6 17 5C F5			Measurement L* (1. st data word) 1. Remove the upper 2 bits of the header information 2. Weighting and addition of 3 bytes $\text{High-Byte} * 2^{12} + \text{Mid-Byte} * 2^6 + \text{Low-Byte}$ 3. Division of the result with 2^9 4. For signed values (e. g.: a* and b*) check, if result is $> 2^8$ --> negative, i. e. result = result - 2^9
	1. (18 Bit Payload) Data word			
	L-Byte	M-Byte	H-Byte	
Hex	23	6E	C3	
Bin	00100011	01101110	11000011	
Without header	100011	101110	000011	
Dez	35	46	3	
Shifting factor		9		
		15267		
Result		29.82		

A 3.9.2 Transmitting Measurement Data to a Measurement Server via Ethernet

When transmitting measurement data to a measurement server, following successful connection (TCP or UDP), the controller sends each measurement to the measurement server or to the connected client. No explicit request is necessary for this.

Any color differences and additional simultaneously logged information for transmission are combined to form a value frame. A number of measurement frames are combined into a measurement block. The block is given a header and fits into a TCP/IP or UDP/IP packet. The header is mandatory at the start of a UDP or TCP packet. If any changes are made to the transmitted data or the frame rate, a new header will be sent automatically.

All measurement data and the header are transmitted in little-endian format.

Preamble (32 bits)	
Part number (32 bits)	
Serial number (32 bits)	
Flags1 (32 bits)	
Flags2 (32 bits)	
Number of frames (16 bits)	Bytes per frame (16 bits)
Counter (32 bits)	

Header entry	Description
Preamble	Recognizes header 0x4D454153 – measurement data 0x56494445 – video data
Part number	
Serial number	
Flags1	Provides information about the contents of the measurement frames
Flags2	Provides information about the contents of the measurement frames, incl. frame rate
Bytes per frame	Number of bytes contained in a measurement frame
Number of frames	Number of frames that this header covers
Counter	Counter with the number of measurements processed

A 3.9.2.1 Description Flags1

Flag bit	Description
0	Video raw signal
1	Video after dark correction
2	Video linearized
3	Video after white balancing/spectrum
4	Dark correction table
5	White correction table
6	Correction table for x from color space XYZ
7	Correction table for y from color space XYZ
8	Correction table for z from color space XYZ
9	Image frequency
10	Exposure time and control event
11	Video array temperature
12	Temperature of the illumination LED
13	Red portion of the illumination LED
14	Green portion of the illumination LED
15	Blue portion of the illumination LED
16	Total brightness of the illumination LED
17	Profile counter
18	Time stamp
19	Measurement data in the XYZ color space

20	Measurement data in the RGB color space
21	Measurement data in the L*a*b* color space
22	Measurement data in the L*u*v* color space
23	Measurement data in the L*C*H° color space
24	Measurement data in the L*a*b*(DIN99) color space
25	Measurement data in the L*C*H(DIN99) color space
26	Active color distance calculation
27	Error status
28	Automatic control behavior
29	Measurement mode control behavior
30	Manual mode control behavior

A 3.9.2.2 Description Flags2

Flag bitDescription

0	Minimum color distance
1	Number of detected color
2	Number of the next color
3	reserved
4	Color distance 1 st color
5	Color distance 2 nd color
6	Color distance 3 rd color
7	Color distance 4 th color
8	Color distance 5 th color
9	Color distance 6 th color
10	Color distance 7 th color
11	Color distance 8 th color
12	Color distance 9 th color
13	Color distance 10 th color
14	Color distance 11 th color
15	Color distance 12 ^h color
16	Color distance 13 th color
17	Color distance 14 th color
18	Color distance 15 th color
19	Color distance 16 th color
20	Statistics min
21	Statistics max
22	Statistics peak-to-peak
23	
24	Distance value per color, array {001}
25	Distance value per color, array {010}
26	Distance value per color, array {100}
27	reserved
28	Number of statistic values array {001}
29	Number of statistic values array {010}
30	Number of statistic values array {100}
31	

A 3.9.3 Ethernet Video Signal Transmission

Like measurement data, video signals are transmitted to a measurement server via Ethernet, see Chap. A 3.9.2, except that only one video signal at a time is transmitted in a measurement value block and each video signal must be requested individually, see Chap. A 3.7.1.

This value block may be sent via several TCP/IP or UDP/IP packets, depending on the size of the video signal.

The preamble for the video signals is 0x56494445 (in accordance with VIDE).

Requesting a video signal:

MEASMODE VIDEO	-> Video mode
OUTVIDEO RAW	-> Issues the raw signal
OUTPUT ETHERNET	-> Output via Ethernet
GETVIDEO	-> The raw signal is transmitted to a server/client

Use the Getvideo command to request one video image at the time. Measurement values and additional signals may be transmitted at the same time, see A 3.6.3.

Note: Correction tables always need to be requested together with one of the video signals.

Group	Name	Index	Ethernet		Scaled		Formula	Unit
			Raw		Min	Max		
Status	Framerate	1	40000	4000000	20.00	2000.00	$1E+6/(x*12.5)*1000$	Hz
	Shutter	2	40000	4000000	20.00	2000.00	$(x*12.5)/10^9$	μ s
	TempDetector	3	-1024	1023	-256.00	255.75	x/4	°C
	TempLightSrc	4	-1024	1023	-256.00	255.75	x/4	°C
Light-Sensor	Red	5	0	65535	0.00	100.00	$x/65536*100$	%
	Green	6	0	65535	0.00	100.00	$x/65536*100$	%
	Blue	7	0	65535	0.00	100.00	$x/65536*100$	%
	Brightness	8	0	65535	0.00	100.00	$x/65536*100$	%
Status	Counter	9	0	4294967296	0	4294967296	x	-
	Timestamp	10	0	4294967296	0.00	4294.97	$x/100000$	s
Color	XYZ	11-13	0	262143	0.00	256.00	$x/1024$	-
	RGB	14-16	0	262143	0.00	256.00	$x/1024$	-
	LAB	17-19	-262144	262143	-256.00	256.00	$x/1024$	-
	LUV	20-22	-262144	262143	-256.00	256.00	$x/1024$	-
	LCH (L/C)	23-24	-262144	262143	-256.00	256.00	$x/1024$	-
	LCH (H)	25	0	524287	0,00	512.00	$x/1024$	°
	LAB99	26-28	-262144	262143	-256.00	256.00	$x/1024$	-
	LCH99 (L/C)	29-30	-262144	262143	-256.00	256.00	$x/1024$	-
LCH99 (H)	31	0	524287	0,00	512.00	$x/1024$	°	
Status	Error	32	0	4294967295	0	4294967295	x	-
Distance	1_1/2/3	33-35	-2097152	2097151	-2048.00	2048.00	$x/1024$	-
	...	36-77	...					
	16_1/2/3	78-80	-2097152	2097151	-2048.00	2048.00	$x/1024$	-
	Min_1/2/3	81-83	-2097152	2097151	-2048.00	2048.00	$x/1024$	-
	DetectedID	84	0	16	0	16	-	-
	MinDistID	85	1	16	0	16	-	-

Fig. 50 Overview output data via Ethernet

A 3.10 Error Messages

The following table contains all error messages:

Error message	Description
E01 unknown command	Unknown command (rights too restricted, cannot read)
E02 wrong or unknown parameter type	A transmitted parameter has an incorrect type, or an incorrect number of parameters was transmitted.
E03 internal error	Internal error code
E04 I/O operation failed	It is not possible to write data to the output channel
E05 the entered command is too long to be processed	The specified command and its parameters are too long (more than 255 bytes).
E06 access denied	Access denied: please log in under the Professional user level
E07 the answer is too long to be displayed by this interpreter	Answer too long
E08 unknown parameter	Unknown parameter
E09 the command or parameter processing has been canceled.	Command was canceled
E10 the command or parameter processing is pending	Command or parameter is being processed
E11 the entered value is out of range or its format is invalid.	One of the parameter values is outside its value range
E12 the info-data of the update are wrong.	Only when updating: the header of the update data contains an error
E13 error during the data transmission for the update	Only when updating: error during transmission of the update data
E14 timeout during the update	Only when updating: timeout during transmission of the update data
E15 update file is too big	Only when updating: update data too large
E16 timeout, command aborted.	Corrections were aborted by a timeout
E17 processing aborted	The process was cancelled
E18 a signal transfer is already active. Please stop this.	A measurement transmission is active, please cancel to allow the command to be executed
E19 the file is not valid for this sensor.	The transmitted parameter file is for a different sensor type.
E20 invalid Filetype	Incorrect file type (setup file or color table)
E21 versions do not match	The versions do not match (setup file or color table)
E22 checksum invalid	Checksum error (setup file or color table)
E23 the set of parameters does not exist	The selected parameter set does not exist.
E24 selection of section invalid	Invalid selection
E26 no signals selected.	No measurements were selected for transmission.
E27 invalid combination of signal parameters - please check measure mode and selected signals	Invalid signal combination, please check measurement mode and selected signals
E28 the entry already exists.	Color exists already

E31 the name of color does not exist	The selected color is not in the color list
E32 timeout	Timeout when setting masters
E33 wrong parameter count	Number of parameters is too high or too small
E34 sensor is uncalibrated	The sensor has not been trained
E35 can not start transfer of measurement data	Output of measurement values cannot be started (corrections only).
E36 Sensor detects too much light, please optimize your measurement setup	Sensor detects too much light, please optimize your measurement setup
E37 Sensor detects not enough light, please optimize your measurement setup	Sensor detects not enough light, please optimize your measurement setup
E38 too much output values for RS422 enabled	Too many output values for the RS422 interface selected
E39 sensor head is empty	Sensor is not available.
E40 it is not possible to use UDP/IP for measurements server	UDP/IP cannot be used for the measurement server
E41 the repeated input of new passwords are not the same	Error when repeating the new password
E42 Sensor detects: too large deviation, please optimize measurement setup and repeat the correction process	Detected deviations are too large, please optimize measurement setup and repeat correction process
E43 Not yet implemented, please take another choice	This feature has not been implemented yet. Please select a different choice.
E44 Color table full	The maximum number of colors for learning has been reached.
E45 No video signal now	No video signal available: please reduce interrogation rate
E46 unsupported character	An unsupported character has been received.
E47 The selection of signals is denied in current measurement mode.	The signal selection may not be changed in this measurement mode.
E48 An automatic adjustment of the illumination LED is only permitted with a manually specified frequency.	An automatic adjustment of the light source LED is permitted only with a manually specified frequency.
E49 Software triggering is not active.	Software trigger is not active.
E50 The number and length of the objects to be mapped would exceed PDO length.	The number and length of the objects which are to be issued would exceed the PDO length.

A 3.11 Warnings

In folgender Tabelle sind alle Warnungen aufgeführt.

W01 EtherCat stopped.	EtherCat was stopped.
W04 The output starts after switch to mode EtherCAT.	The output is activated after switching to the EtherCAT mode.
W05 EtherCAT will be activated after saving the settings and restarting the controller.	EtherCAT is activated only after saving the settings and reboot the controller.
W06 Data request has been modified by the system, a reason for this could be the selection of a statistic signal.	Data request through the system modified. The reason may be the selection of a statistical signal.

A 4 EtherCAT-Dokumentation

EtherCAT® is, from the Ethernet viewpoint, a single, large Ethernet station that transmits and receives Ethernet telegrams. Such an EtherCAT system consists of an EtherCAT master and up to 65535 EtherCAT slaves.

Master and slaves communicate via a standard Ethernet wiring. On-the-fly processing hardware is used in each slave. The incoming Ethernet frames are directly processed by the hardware. Relevant data are extracted or added from the frame. The frame is subsequently forwarded to the next EtherCAT® slave device. The completely processed frame is sent back from the last slave device. Various protocols can be used in the application level. CANopen over EtherCAT technology (CoE) is supported here. In the CANopen protocol, an object tree with Service Data Objects (SDO) and Process Data Objects (PDO) is used to manage the data.

Further information can be obtained from ® Technology Group (www.ethercat.org) or Beckhoff GmbH, (www.beckhoff.com).

A 4.1 Preamble

A 4.1.1 Structure of EtherCAT®-Frames

The transfer of data occurs in Ethernet frames with a special Ether type (0x88A4). Such an EtherCAT® frame consists of one or several EtherCAT® telegrams, each of which is addressed to individual slaves / storage areas. The telegrams are either transmitted directly in the data area of the Ethernet frame or in the data area of the UDP datagram. An EtherCAT® telegram consists of an EtherCAT® header, the data area and the work counter (WC). The work counter is incremented by each addressed EtherCAT® slave that exchanged the corresponding data.

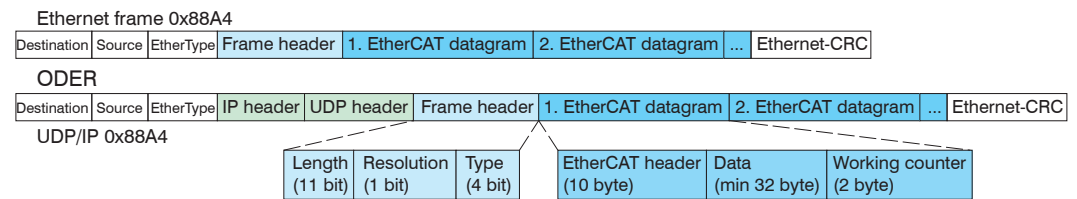

Fig. 51 Setup of EtherCAT frames

A 4.1.2 EtherCAT® Services

In EtherCAT® services for the reading and writing of data are specified in the physical memory of the slave hardware. The following EtherCAT® services are supported by the slave hardware:

- APRD (Autoincrement physical read, Reading of a physical area with auto-increment addressing)
- APWR (Autoincrement physical write, Writing of a physical area with auto-increment addressing)
- APRW (Autoincrement physical read write, Reading and writing of a physical area with auto-increment addressing)
- FPRD (Configured address read, Reading of a physical area with fixed addressing)
- FPWR (Configured address write, Writing of a physical area with fixed addressing)
- FPRW (Configured address read write, Reading and writing of a physical area with fixed addressing)
- BRD (Broadcast Read, Broadcast Reading of a physical area for all slaves)
- BWR (Broadcast Write, Broadcast Writing of a physical area for all slaves)
- LRD (Logical read, Reading of a logical storage area)
- LWR (Logical write, Writing of a logical storage area)
- LRW (Logical read write, Reading and writing of a logical storage area)
- ARMW (Auto increment physical read multiple write, Reading of a physical area with auto-increment addressing, multiple writing)

- FRMW (Configured address read multiple write, Reading of a physical area with fixed addressing, multiple writing)

A 4.1.3 Addressing and FMMUs

In order to address a slave in the EtherCAT® system, various methods from the master can be used. The ACS7000 supports as full slave:

- Position addressing
The slave device is addressed via its physical position in the EtherCAT® segment. The services used for this are APRD, APWR, APRW.
- Node addressing
The slave device is addressed via a configured node address, which was assigned by the master during the commissioning phase. The services used for this are FPRD, FPWR and FPRW.
- Logical addressing
The slaves are not addressed individually; instead, a segment of the segment-wide logical 4-GB address is addressed. This segment can be used by a number of slaves. The services used for this are LRD, LWR and LRW.

The local assignment of physical slave memory addresses and logical segment-wide addresses is implemented via the field bus Memory Management Units (FMMUs). The configuration of the slave FMMUs is implemented by the master. The FMMU configuration contains a start address of the physical memory in the slave, a logical start address in the global address space, length and type of the data, as well as the direction (input or output) of the process data.

A 4.1.4 Sync Manager

Sync Managers serve the data consistency during the data exchange between EtherCAT® master and slaves. Each Sync Manager channel defines an area of the application memory. The ACS7000 has four channels:

- Sync-Manager Channel 0: Sync Manager 0 is used for mailbox write transfers (mailbox from master to slave).
- Sync-Manager Channel 1: Sync Manager 1 is used for mailbox read transfers (mailbox from slave to master).
- Sync-Manager Channel 2: Sync Manager 2 is usually used for process output data. Not used in the sensor.
- Sync-Manager Channel 3: Sync Manager 3 is used for process input data. It contains the Tx PDOs that are specified by the PDO assignment object 0x1C13 (hex.).

A 4.1.5 EtherCAT State Machine

The EtherCAT® state machine is implemented in each EtherCAT®. Directly after switching on the ACS7000, the state machine is in the "Initialization" state. In this state, the master has access to the DLL information register of the slave hardware. The mailbox is not yet initialized, i.e. communication with the application (sensor software) is not yet possible. During the transition to the pre-operational state, the Sync Manager channels are configured for the mailbox communication. In the „Pre-Operational“ state, communication via the mailbox is possible, and it can access the object directory and its objects. In this state, no process data communication occurs. During the transition to the „Safe-Operational“ state, the process-data mapping, the Sync Manager channel of the process inputs and the corresponding FMMU are configured by the master. Mailbox communication continues to be possible in the „Safe-Operational“ state. The process data communication runs for the inputs. The outputs are in the „safe“ state. In the „Operational“ state, process data communication runs for the inputs as well as the outputs.

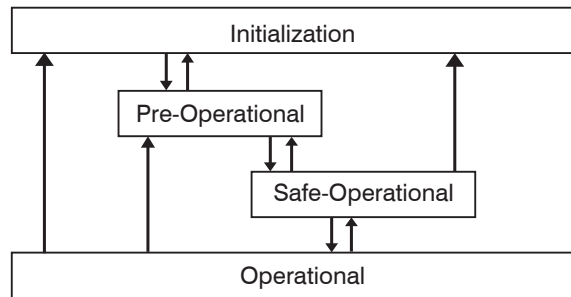

Fig. 52 EtherCAT State Machine

A 4.1.6 CANopen over EtherCAT

The application level communication protocol in EtherCAT is based on the communication profile CANopen DS 301 and is designated either as “CANopen over EtherCAT” or CoE. The protocol specifies the object directory in the sensor, as well as the communication objects for the exchange of process data and acyclic messages. The sensor uses the following message types:

- Process Data Object (PDO). The PDO is used for the cyclic I/O communication, therefore for process data.
- Service Data Object (SDO). The SDO is used for acyclic data transmission.

The object directory is described in the chapter CoE Object Directory.

A 4.1.7 Process Data PDO Mapping

The EtherCAT interface enables a fast transmission of measured values. Process Data Objects (PDOs) are used for the exchange of time-critical process data between master and slaves. Tx PDOs are used for the transmission of data from the slaves to the master (process inputs), Rx PDOs are used to transmit data from the master to the slaves (process outputs); not used in the ACS7000. The PDO mapping defines which application objects (measurement data) are transmitted into a PDO. The ACS7000 has a Tx PDO for the measuring data.

The following system-, color- and color distance values are available as process data:

- Frequency select
- Shutter select
- Line temperature
- Light source temperature
- Light sensor brightness channel
- Light sensor blue channel
- Light sensor green channel
- Light sensor red channel
- Value counter
- Timestamp
- Sensor state
- Statistic min
- Statistic max
- Statistic peak-peak

Color values in different color spaces:

- XYZ color values
- RGB color values
- L*a*b* color values
- L*u*v* color values
- L*C*h° color values
- Lab99 color values
- LCh99 color values

You will find details on color spaces in the sections color measurement, see Chap. 5.5, see Chap. A 3.6.3.2.

Color distance values:

- Number of detected color
- Number of color with min. distance
- Min. color distance
- Color distance no. 1
- Color distance no. 2
- ...
- Color distance no. 16

You will find details on color distances in the sections color tolerance parameter, see Chap. 5.4.3, see Chap. A 3.6.3.3.

In EtherCAT the PDOs are transported in objects of the Sync Manager channel. The sensor uses the Sync Manager channel SM3 for input data (Tx data). The PDO assignments of the Sync Manager can only be changed in the “Pre-Operational” state. The mapping in the ACS7000 is not carried out directly in the object 0x1A00, but rather by switching on and off individual measurements in the application object 0x21B0. The mapping result is available to the master after reloading the object directory.

Note: Subindex 0h of the object 0x1A00 contains the number of valid entries within the mapping report. This number also represents the number of application variables (parameters) that should be transmitted/received with the corresponding PDO. The subindices from 1h up to the number of objects contain information about the depicted application variables. The mapping values in the CANopen objects are coded in hexadecimal form.

The following table contains an example of the entry structure of the PDO mapping:

MSB			LSB		
31	16	15	8	7	0
Index e.g. 0x6060 (16 bits)		Subindex e.g. 0x02		Object length in bits, e.g. 20h = 32 bits	

Fig. 53 Entry structure of the PDO mapping, example

A 4.1.8 Service Data SDO Service

Service Data Objects (SDOs) are primarily used for the transmission of data that are not time critical, e.g. parameter values. EtherCAT specifies the SDO services as well as the SDO information services: SDO services make possible the read/write access to entries in the CoE object directory of the device. SDO information services make it possible to read the object directory itself and to access the properties of the objects. All parameters of the measuring device can be read or changed in this way, or measurements can be transmitted. A desired parameter is addressed via index and subindex within the object directory.

A 4.2 CoE – Object Directory

The CoE object directory (CANopen over EtherCAT) contains all the configuration data of the sensor. The objects in CoE object directory can be accessed using the SDO services. Each object is addressed using a 16-bit index.

A 4.2.1 Communication Specific Standard Objects (CiA DS-301)

Overview

Index (h)	Name	Description
1000	Device type	Device type
1001	Error register	Error register
1003	Error history	Predefined error field
1008	Device name	Manufacturer device name
1009	Hardware version	Hardware version
100A	Software version	Software version
1018	Identity	Device identification
1A00	Sample 0	TxPDO mapping
1C00	Sync. manager type	Synch. manager type
1C13	TxPDO assign	TxPDO assign
1C33	SM input parameter	Synchronous mode parameter (DC)

Object 1000h: Device type

1000	VAR	Device type	0x00200000	Unsigned32	ro
------	-----	-------------	------------	------------	----

Provides informations about the used device profile and the device type.

Object 1001h: Error register

1001	VAR	Error register	0x00	Unsigned8	ro
------	-----	----------------	------	-----------	----

The error register contains generic informations about the kind of the internally adjacent device errors. The general error bit is set on each case.

Structure of error register

7	6	5	4	3	2	1	0
Manufacturer	Reserved	Reserved	Reserved	Reserved	Reserved	Reserved	General

Object 1003h: Predefined error field

1003	RECORD	Error history			
------	--------	---------------	--	--	--

Subindices

0	VAR	Number of entries	1	Unsigned8	rw
1	VAR			Unsigned32	ro

The occurring device errors are registered here. The last error is saved in the error field. The entry under Sub-Index 0 contains the number of saved errors, by writing the value 0, the errors are eliminated.

Object 1008h: Manufacturer device name

1008	VAR	Device name	IFC24x1	Visible String	ro
------	-----	-------------	---------	----------------	----

Object 1009h: Hardware version

1009	VAR	Hardware version	V x.xxx	Visible String	ro
------	-----	------------------	---------	----------------	----

Object 100Ah: Software-Version

100A	VAR	Software version	V x.xxx	Visible String	ro
------	-----	------------------	---------	----------------	----

Object 1A00h: TxPDO Mapping (Example)					
1A00	RECORD	TxPDO Mapping			
Subindices					
0	VAR	Number of entries	31	Unsigned8	ro
1	VAR	Frequency select	0x60600120	Unsigned32	ro
2	VAR	Shutter select	0x60600220	Unsigned32	ro
3	VAR	Line temperature	0x60600320	Unsigned32	ro
4	VAR	Light source temperature	0x60600420	Unsigned32	ro
5	VAR	Light sensor brightness channel	0x60600520	Unsigned32	ro
6	VAR	Light sensor blue channel	0x60600620	Unsigned32	ro
7	VAR	Light sensor green channel	0x60600720	Unsigned32	ro
8	VAR	Light sensor red channel	0x60600820	Unsigned32	ro
9	VAR	Value counter	0x60600920	Unsigned32	ro
10	VAR	Time stamp	0x60600A20	Unsigned32	ro
11	VAR	XYZ color value X	0x60650120	Unsigned32	ro
12	VAR	XYZ color value Y	0x60650220	Unsigned32	ro
13	VAR	XYZ color value Z	0x60650320	Unsigned32	ro
14	VAR	RGB color value R	0x60660120	Unsigned32	ro
15	VAR	RGB color value G	0x60660220	Unsigned32	ro
16	VAR	RGB color value B	0x60660320	Unsigned32	ro
17	VAR	L*a*b* color value L*	0x60670120	Unsigned32	ro
18	VAR	L*a*b* color value a*	0x60670220	Unsigned32	ro
19	VAR	L*a*b* color value b*	0x60670320	Unsigned32	ro
20	VAR	L*u*v* color value L*	0x60680120	Unsigned32	ro
21	VAR	L*u*v* color value u*	0x60680220	Unsigned32	ro
22	VAR	L*u*v* color value v*	0x60680320	Unsigned32	ro
23	VAR	L*C*h° color value L*	0x60690120	Unsigned32	ro
24	VAR	L*C*h° color value C*	0x60690220	Unsigned32	ro
25	VAR	L*C*h° color value h°	0x60690320	Unsigned32	ro
26	VAR	Lab99 color value L*99	0x606A0120	Unsigned32	ro
27	VAR	Lab99 color value a*99	0x606A0220	Unsigned32	ro
28	VAR	Lab99 color value b*99	0x606A0320	Unsigned32	ro
29	VAR	LCh99 color value L*99	0x606B0120	Unsigned32	ro
30	VAR	LCh99 color value C*99	0x606B0220	Unsigned32	ro
31	VAR	LCh99 color value h°99	0x606B0320	Unsigned32	ro

Object 1C00h: Synchronous manager type

1C00	RECORD	Sync manager type			ro
Subindices					
0	VAR	Number of entries	4	Unsigned8	ro
1	VAR	Sync manager 1	0x01	Unsigned8	ro
2	VAR	Sync manager 2	0x02	Unsigned8	ro
3	VAR	Sync manager 3	0x03	Unsigned8	ro
4	VAR	Sync manager 4	0x04	Unsigned8	ro

Object 1C13h: TxPDO assign

1C13	RECORD	TxPDO assign			
Subindices					
0	VAR	Number of entries	1	Unsigned8	ro
1	VAR	Subindex 001	0x1A00	Unsigned16	ro

Object 1C33h: SM input parameter

1C33	RECORD	SM input parameter			ro
Subindices					
0	VAR	Number of entries	32	Unsigned8	ro
1	VAR	Sync mode	0	Unsigned8	ro
2	VAR	Cycle time	100000	Unsigned32	ro
4	VAR	Sync modes supported	0x4005	Integer16	ro
5	VAR	Minimum cycle time	1000000	Integer32	ro
6	VAR	Calc and copy time	0	Integer32	ro
8	VAR	Get cycle time	0	Integer16	rw
11	VAR	SM event missed counter	0	Integer32	ro
12	VAR	Cycle exceeded counter	0	Integer32	ro
32	VAR	Sync error	FALSE	Bool	ro

A 4.2.2 Manufacturer Specific Objects**Overview**

Index (h)	Name	Description
2001	User level	Login, logout, change Pass word
2005	Controller info	Controller informations (further)
2010	Setup	Load/save settings
2011	Correction	Light and dark correction
2101	Reset	Reset des Controllers
2105	Factory settings	Reset factory settings
2131	Light source info	
2154	Measuring program	Measuring program
2157	Standard observer / illumination / color distance	Options
2181	Averaging/error handling/statistics	Averaging/error handling/statistics and spike correction
21B0	Digital interfaces	Digital interfaces, data selection
21B1	Color values	Color space selection in color measurement mode
21B2	Delta values	Selection of the saved colors for color difference measurement
21C0	Ethernet	Ethernet parameter (IP address, Subnet, Gateway, ...)
2202	ColorOut settings	Color outputs
2250	Shutter mode/measuring rate	Shutter mode/measuring rate
2410	Trigger mode	Trigger modes
24A0	Keylock	Keylock
2810	Color entry	Color informations
2811	Color selection	Color selection
2812	Color table edit	Color table edit
2815	Threshold entry	
2816	Threshold selection	
603F	Sensor error	Error message of the sensor
6060	System values	General sensor values (Value counter, ...)
6065	XYZ color values	Color value in the XYZ color space
6066	RGB color values	Color value in the RGB color space
6067	L*a*b* color values	Color value in the L*a*b* color space
6068	L*u*v* color values	Color value in the L*u*v* color space
6069	L*C*h° color values	Color value in the L*C*h° color space
606A	Lab99 color values	Color value in the im Lab99 color space
606B	LCh99 color values	Color value in the im LCh99 color space
6070	Color detection	Detected color
6075	Min. color distance	Minimal color distance
6080	Color distance no. 1	Distance to color 1
6081	Color distance no. 2	Distance to color 2
6082	Color distance no. 3	Distance to color 3
6083	Color distance no. 4	Distance to color 4
6084	Color distance no. 5	Distance to color 5
6085	Color distance no. 6	Distance to color 6
6086	Color distance no. 7	Distance to color 7
6087	Color distance no. 8	Distance to color 8
6088	Color distance no. 9	Distance to color 9
6089	Color distance no. 10	Distance to color 10
608A	Color distance no. 11	Distance to color 11

608B	Color distance no. 12	Distance to color 12
608C	Color distance no. 13	Distance to color 13
608D	Color distance no. 14	Distance to color 14
608E	Color distance no. 15	Distance to color 15
608F	Color distance no. 16	Distance to color 16
60C0	Statistic for color value component 1	Statistic for color component 1 (X, R, L*)
60C1	Statistic for color value component 2	Statistic for color component 2 (Y, G, a*, u*, C*)
60C2	Statistic for color value component 3	Statistic for color component 3 (Z, B, b*, v*, h°)
60E0	Statistic for color distance component 1	Statistic for color distance component 1 (L*)
60E1	Statistic for color distance component 2	Statistic for color distance component 2 (a*)
60E2	Statistic for color distance component 3	Statistic for color distance component 3 (b*)
60E3	Statistic for color distance component 4	Statistic for color distance component 4 (ab*)
60E4	Statistic for color distance component 5	Statistic for color distance component 5 (E)

The objects 6065 to 60E4 are only available in the corresponding measurement programs.

Object 2001h: User level

2001	RECORD	User level			
------	--------	------------	--	--	--

Subindices

0	VAR	Number of entries	7	Unsigned8	ro
1	VAR	Actual user	x	Unsigned8	ro
2	VAR	Login	*****	Visible string	wo
3	VAR	Logout	FALSE	BOOL	rw
4	VAR	Default user	x	Unsigned8	rw
5	VAR	Password old	*****	Visible string	wo
6	VAR	Password new	*****	Visible string	wo
7	VAR	Password repeat	*****	Visible string	wo

Further details can be found in the section Login, Switching User Level, see Chap. 5.3.2.

Actual user, Default user:

0 - User

1 - Professional

For changing the password, the three password fields Old, New and Repeat must be described in the specified sequence. The maximum length of a password is 31 characters.

Object 2005h: Controller informations (further)

2005	RECORD	Controller Info			ro
------	--------	-----------------	--	--	----

Subindices

0	VAR	Number of entries	8	Unsigned8	ro
1	VAR	Name	ACS7000	Visible String	ro
5	VAR	Serial No	xxxxxxx	Visible String	ro
6	VAR	Option No	xxx	Visible String	ro
8	VAR	Article No	xxxxxxx	Visible String	ro

Further details can be found in the section Controller Information, see Chap. A 3.3.1.2.

Object 2010h: Loading/saving settings

2010	RECORD	Setup			ro
------	--------	-------	--	--	----

Subindices

0	VAR	Number of entries	4	Unsigned8	ro
1	VAR	Setup number	0x0001	Unsigned8	rw
2	VAR	Setup store	FALSE	BOOL	rw
3	VAR	Setup read	FALSE	BOOL	rw
4	VAR	Keep device settings	FALSE	BOOL	rw

Further details can be found in the section Load/Save Setup in the controller, see Chap. [5.3.15](#) and Parameter Management, Load/Save Settings, see Chap. [A 3.3.5](#).

Object 2011h: Corrections

2011	RECORD	Correction			ro
------	--------	------------	--	--	----

Subindices

0	VAR	Number of entries	3	Unsigned8	ro
1	VAR	Dark reference	FALSE	BOOL	rw
2	VAR	White reference	FALSE	BOOL	rw
3	VAR	Bright reference	FALSE	BOOL	rw
4	VAR	Correction result	0x00	Unsigned32	ro

Further details can be found in the section Corrections, Referencing, see Chap. [5.3.6](#), Dark Reference, see Chap. [A 3.3.3.4](#) and White Balance, see Chap. [A 3.3.3.5](#).

After triggering a correction the status (error code) of the correction can be queried under `Correction result`. You can read under section Error Messages, see Chap. [A 3.10](#), for the possible error codes.

Object 2101h: Reset

2101	VAR	Reset	FALSE	BOOL	rw
------	-----	-------	-------	------	----

Controller is restarted, all open TCP connections are hereby closed.

Object 2105h: Factory settings

2105	RECORD	Factory settings			ro
------	--------	------------------	--	--	----

Subindices

0	VAR	Number of entries	3	Unsigned8	ro
1	VAR	Set factory settings	FALSE	BOOL	rw
2	VAR	Reset color table	FALSE	BOOL	rw
3	VAR	Delete all setups	FALSE	BOOL	rw
4	VAR	Delete current setup	FALSE	BOOL	rw
5	VAR	Keep device settings	FALSE	BOOL	rw
6	VAR	Save interface settings	FALSE	BOOL	rw

Further details can be found in the section Extras, see Chap. [5.3.17](#) and Default Settings, see Chap. [A 3.3.5.3](#).

Object 2131h: Light source

2131	RECORD	Light source info			ro
Subindices					
0	VAR	Number of entries	6	Unsigned8	ro
1	VAR	Configuration LED segments	0x00(0)	Unsigned8	rw
2	VAR	Intensity quadrant: cold white	0x03FF(1023)	Unsigned16	ro
3	VAR	Intensity quadrant: green	0x03FF(1023)	Unsigned16	ro
4	VAR	Intensity quadrant: warm white	0x03FF(1023)	Unsigned16	ro
5	VAR	Intensity quadrant: violet	0x03FF(1023)	Unsigned16	ro
6	VAR	Light source adjustment	FALSE	BOOL	rw

Further details can be found in the section Output Light Source Intensities, see Chap. A 3.3.3.2, see Chap. A 3.3.3.3.

Configuration LED segments:

- 0 - Max
- 1 - Min
- 2 - Manual
- 3 - Auto
- 4 - Off

Object 2154h: Measuring program

2154	RECORD	Measuring program			ro
Subindices					
0	VAR	Number of entries	2	Unsigned8	ro
1	VAR	Measuring program	0x00(0)	Unsigned8	rw
2	VAR	Best-Hit mode	0x00(0)	Unsigned8	rw

Further details can be found in the section Digital Interfaces/Parameters Overview, see Chap. 5.3.9.1 and Measuring Mode, see Chap. A 3.6.2.

Measuring program:

- 0 - Color measurement
- 1 - Color detection, see Chap. A 3.6.2

Best-Hit mode (in measuring program color difference measurement):

- 0 - Selected mode
- 1 - Best-Hit mode color difference measurement

Object 2157h: Measurement settings

2157	RECORD	Standard observer / illumination / color distance			ro
Subindices					
0	VAR	Number of entries	6	Unsigned8	ro
1	VAR	Standard observer	0x00(0)	Unsigned8	rw
2	VAR	Standard illuminant	0x02(2)	Unsigned8	rw
3	VAR	Distance model	0x00(0)	Unsigned8	rw
4	VAR	Weighting factor kL	1.0	FLOAT32	ro
5	VAR	Weighting factor kC	1.0	FLOAT32	ro
6	VAR	Weighting factor kH	1.0	FLOAT32	ro

Standard observer:

- 2 - 2°
- 10 - 10°

Standard illuminant:

- 0 - D50
- 1 - D65
- 2 - D75
- 3 - A
- 4 - C
- 5 - E
- 6 - F4
- 7 - F7
- 8 - F11

Distance model:

- 0 - Sphere (0: Euclidean, 1: DIN99, 2: CIE94, 3: CMC, 4: CIEDE200)
- 8 - Cylinder
- 16 - Box

Further details can be found in section Standard Observer, see Chap. 5.3.7.

Object 2181h: Averaging, error processing and statistics

2181	RECORD	Averaging/error handling/statistics			ro
------	--------	-------------------------------------	--	--	----

Subindices

0	VAR	Number of entries	10	Unsigned8	ro
1	VAR	Measured value averaging type	x	Unsigned8	rw
2	VAR	Number of values for moving average	x	Unsigned16	rw
3	VAR	Number of values for median	x	Unsigned8	rw
4	VAR	Number of values for recursive average	x	Unsigned16	rw
5	VAR	Statistic depth	x	Unsigned16	rw
6	VAR	Reset statistic	FALSE	BOOL	rw
7	VAR	Error handling	x	Unsigned8	rw
8	VAR	Number of held values	x	Unsigned16	rw
9	VAR	Video averaging	x	Unsigned8	rw
10	VAR	Signal for statistics	x	Unsigned8	rw

Further details can be found in section Averaging/Error Handling/Statistics, see Chap. 5.3.10, see Chap. A 3.5.2.

Measured value averaging type:

- 0 - No averaging
- 1 - Moving averaging value (Number of values for moving average: 2, 4, 8, 16, 32, 64, 128, 256, 512 and 1024)
- 2 - Recursive averaging value (Number of values for recursive average: 2...32768)
- 3 - Median (Number of values for median: 3, 5, 7 and 9)

Statistic depth:

0, 2, 4, 8, 16...16384; 0 = infinite

Error handling:

- 0 - Output of error value
- 1 - Hold last valid value for a number of measurement values (Number of held values: 0...1024, 0 = infinite)

Video averaging:

- 0 - No averaging
- 1 - Recursive average of 2 video signals
- 2 - Recursive average of 4 video signals
- 3 - Recursive average of 8 video signals
- 4 - Recursive average of 16 video signals
- 5 - Recursive average of 32 video signals
- 6 - Recursive average of 64 video signals
- 7 - Recursive average of 128 video signals
- 8 - Reduction to 256 points and 8 bit

Statistic signal:

- 0 - No statistics
- 1 - Color value in the XYZ color space
- 2 - Color value in the RGB color space
- 3 - Color value in the L*a*b* color space
- 4 - Color value in the L*u*v* color space
- 5 - Color value in the L*C*h° color space
- 6 - Color value in the Lab99 color space
- 7 - Color value in the LCh99 color space
- 8 - Distance to color 1
- 9 - Distance to color 2
- 10 - Distance to color 3
- 11 - Distance to color 4
- 12 - Distance to color 5
- 13 - Distance to color 6
- 14 - Distance to color 7
- 15 - Distance to color 8
- 16 - Distance to color 9
- 17 - Distance to color 10
- 18 - Distance to color 11
- 19 - Distance to color 12
- 20 - Distance to color 13
- 21 - Distance to color 14
- 22 - Distance to color 15
- 23 - Distance to color 16
- 24 - Minimum color distance
- 25 - Number of the detected color
- 26 - Number of color with the smallest distance

Object 21B0h: Digital interfaces, selection of transmitted data (measurement values)

21B0	RECORD	Digital interfaces			ro
Subindices					
0	VAR	Number of entries	17	Unsigned8	ro
1	VAR	Output device	5	Unsigned8	rw
2	VAR	RS422 baud rate	x	Unsigned32	rw
3	VAR	Ethernet/EtherCAT	TRUE	BOOL	rw
4	VAR	Frequency select	TRUE	BOOL	rw
5	VAR	Shutter select	FALSE	BOOL	rw
6	VAR	Line temperature	FALSE	BOOL	rw
7	VAR	Light source temperature	FALSE	BOOL	rw
8	VAR	Light sensor brightness channel	FALSE	BOOL	rw
9	VAR	Light sensor blue channel	FALSE	BOOL	rw
10	VAR	Light sensor green channel	FALSE	BOOL	rw
11	VAR	Light sensor red channel	FALSE	BOOL	rw
12	VAR	Value counter	FALSE	BOOL	rw
13	VAR	Time stamp	FALSE	BOOL	rw
14	VAR	Sensor state	FALSE	BOOL	rw
15	VAR	Statistic min	FALSE	BOOL	rw
16	VAR	Statistic max	FALSE	BOOL	rw
17	VAR	Statistic peak-peak	FALSE	BOOL	rw

Output device:

- 1 - RS422
- 5 - EtherCAT

RS422 baud rate: 9600, 115200, 230400, 460800, 691200, 921600, 1500000, 2000000, 3500000, 4000000

Ethercat-Ethernet: (Change of interface)

- 0 - Ethernet (works only from restarting, previously setup store)
- 1 - EtherCAT

Subindices 4 ... 17: Data selection for the PDO mapping

Object 21B1h: Selection of the transmitted color measured values

21B1	RECORD	Color values			ro
Subindices					
0	VAR	Number of entries	7	Unsigned8	ro
1	VAR	XYZ color values	TRUE	BOOL	rw
2	VAR	RGB color values	FALSE	BOOL	rw
3	VAR	L*a*b* color values	FALSE	BOOL	rw
4	VAR	L*u*v* color values	FALSE	BOOL	rw
5	VAR	L*C*h° color values	FALSE	BOOL	rw
6	VAR	Lab99 color values	FALSE	BOOL	rw
7	VAR	LCh99 color values	FALSE	BOOL	rw

Object 21B2h: Selection of the transmitted color differences

21B2	RECORD	Delta values			ro
Subindices					
0	VAR	Number of entries	20	Unsigned8	ro
1	VAR	Number of detected color	TRUE	BOOL	rw
2	VAR	Number of color with min. distance	FALSE	BOOL	rw
3	VAR	Min. color distance	FALSE	BOOL	rw
4	VAR	Color distance no. 1	FALSE	BOOL	rw
5	VAR	Color distance no. 2	FALSE	BOOL	rw
6	VAR	Color distance no. 3	FALSE	BOOL	rw
7	VAR	Color distance no. 4	FALSE	BOOL	rw
8	VAR	Color distance no. 5	FALSE	BOOL	rw
9	VAR	Color distance no. 6	FALSE	BOOL	rw
10	VAR	Color distance no. 7	FALSE	BOOL	rw
11	VAR	Color distance no. 8	FALSE	BOOL	rw
12	VAR	Color distance no. 9	FALSE	BOOL	rw
13	VAR	Color distance no. 10	FALSE	BOOL	rw
14	VAR	Color distance no. 11	FALSE	BOOL	rw
15	VAR	Color distance no. 12	FALSE	BOOL	rw
16	VAR	Color distance no. 13	FALSE	BOOL	rw
17	VAR	Color distance no. 14	FALSE	BOOL	rw
18	VAR	Color distance no. 15	FALSE	BOOL	rw
19	VAR	Color distance no. 16	FALSE	BOOL	rw
20	VAR	ColorValues at Detection Mode	FALSE	BOOL	rw

Color distance no. 1 to 16 can only be selectable when color difference measurement (object 0x2154.1) and Selected mode (Best-Hit mode Object 0x2154.2).

Object 21C0h: Ethernet

21C0	RECORD	Ethernet			ro
------	--------	----------	--	--	----

Subindices

0	VAR	Number of entries	8	Unsigned8	ro
1	VAR	IP address	xxx.xxx.xxx.xxx	Visible String	rw
2	VAR	Subnet mask	xxx.xxx.xxx.xxx	Visible String	rw
3	VAR	Gateway	xxx.xxx.xxx.xxx	Visible String	rw
4	VAR	DHCP	FALSE	BOOL	rw
5	VAR	Measured value server protocol	0	Unsigned8	rw
6	VAR	Measured value server IP address	xxx.xxx.xxx.xxx	Visible String	rw
7	VAR	Measured value server port	x	Unsigned16	rw
8	VAR	MAC address	xx.xx.xx.xx.xx.xx	Visible String	ro

Further details can be found in section Ethernet settings, see Chap. [5.3.9.3](#), see Chap. [A 3.3.4.2](#), see Chap. [A 3.3.4.3](#).

DHCP:

- 0 - Static IP address
- 1 - DHCP

Measured value server protocol:

- 0 - No transmission
- 1 - Client/TCP
- 2 - Client/UDP
- 3 - Server/TCP

Object 2202h: Color output

2202	RECORD	ColorOut settings			ro
------	--------	-------------------	--	--	----

Subindices

0	VAR	Anzahl Einträge	3	Unsigned8	ro
1	VAR	Output mode	x	Unsigned8	rw
2	VAR	Binary format	x	Unsigned8	rw
3	VAR	Color to compare	x	Unsigned8	ro

Further details can be found in the section ColorOut, see Chap. [5.3.9.5](#), see Chap. [A 3.3.4.5](#).

Object 2250h: Exposure mode/Measuring rate

2250	RECORD	Shutter mode/measuring rate			
------	--------	-----------------------------	--	--	--

Subindices

0	VAR	Number of entries	5	Unsigned8	ro
1	VAR	Shutter mode	x	Unsigned8	rw
2	VAR	Measuring rate	x	Unsigned8	rw
5	VAR	Manual measuring rate	xxx	Unsigned32	rw

Further details can be found in the section Measuring Rate, see Chap. 5.3.4.

Shutter mode:

- 0 - Automatic (to determine the optimal exposure time resp. measuring rate)
- 1 - Measurement mode (exposure time control with a fixed measuring rate, recommended for measurement)
- 2 - Manual mode (freely selectable fixed exposure time resp. measuring rate)

Measuring rate:

Setting value	Frequency
0	2000 Hz
1	1000 Hz
2	500 Hz
3	250 Hz
6	extern (Distributed clock)
7	manuell

Manual measuring rate: 20 ... 2000 Hz

Object 2410h: Triggermodes

2410	RECORD	Trigger mode			ro
------	--------	--------------	--	--	----

Subindices

0	VAR	Number of entries	8	Unsigned8	ro
1	VAR	Trigger mode	0x00(0)	Unsigned8	rw
2	VAR	Trigger edge/level	0x00(0)	Unsigned8	rw
3	VAR	Number of values per trigger pulse	0x0001(1)	Unsigned16	rw
8	VAR	Software trigger pulse	FALSE	BOOL	rw

Further details can be found in the section Trigger Mode, see Chap. 5.3.12, see Chap. A 3.7.4.

Trigger mode:

- 0 - No triggering
- 1 - Level triggering
- 2 - Edge triggering
- 3 - Software triggering

Trigger edge/level:

- 0 - At edge triggering: Falling edge; at level triggering: Low
- 1 - At edge triggering: Rising edge; at level triggering: High

Number of value per trigger pulse:

Number of output data after a trigger pulse for edge or software triggering, 0...16382, 16383 = infinite, 0 = Stop

Object 24A0h: Keylock

24A0	RECORD	Keylock			ro
Subindices					
0	VAR	Number of entries	2	Unsigned8	ro
1	VAR	Keylock active on system startup	FALSE	Unsigned8	rw
2	VAR	Minutes until the automatic keylock is activated	0x0005(5)	Unsigned16	rw

Keylock active on system startup:

- 0 - deactivated
- 1 - active
- 2 - Auto

Minutes until the automatic keylock is activated:

- 0 ... 65535

Object 2810h: Color informations

2810	RECORD	Color entry			
Subindices					
0	VAR	Number of entries	14	Unsigned8	ro
1	VAR	Color name	xxxxx	Visible String	rw
2	VAR	Color description	xxxxxx	Visible String	rw
3	VAR	Description by	0x00(0)	Unsigned8	rw
4	VAR	L*	x.xxxx	FLOAT32	ro
5	VAR	a*	x.xxxx	FLOAT32	ro
6	VAR	B*	x.xxxx	FLOAT32	ro
7	VAR	X	x.xxxx	FLOAT32	ro
8	VAR	Y	x.xxxx	FLOAT32	ro
9	VAR	Z	x.xxxx	FLOAT32	ro
10	VAR	R	x.xxxx	FLOAT32	ro
11	VAR	G	x.xxxx	FLOAT32	ro
12	VAR	B	x.xxxx	FLOAT32	ro
13	VAR	Standard observer	0x0A(10)	Unsigned8	rw
14	VAR	Standard illuminant	D75	Unsigned8	rw

Further details can be found in the section Color Table, see Chap. [5.3.8.1](#)

Color name: currently selected color

Color description: Description of the currently selected color

L*, a*, b*, X, Y, Z, R, G and B: Coordinates of the color in the respective color spaces

Description by:

- 0 - Spectrum
- 1 - XYZ
- 2 - LAB

Standard observer:

- 2 - 2°
- 10 - 10°

Standard illuminant:

- 0 - D50
- 1 - D65
- 2 - D75
- 3 - A
- 4 - C
- 5 - E
- 6 - F4
- 7 - F7
- 8 - F11

Object 2811h: Select color

2811	RECORD	Color selection			
------	--------	-----------------	--	--	--

Subindices

0	VAR	Number of entries	4	Unsigned8	ro
1	VAR	Color ids	1, 2, 3,	Visible String	ro
2	VAR	Selected color for edit	0x01(1)	Unsigned8	rw
3	VAR	Move color	0x00(0)	Unsigned8	rw
4	VAR	Reset mapping	FALSE	BOOL	rw

Color ids:	Output of all colors contained in the color table
Selected color for edit:	Select a color from a color table, which can be displayed and edited in the 0x2810 “Color entry“ object.
Move color:	Shifts the color entry at the specified position in the color table.
Reset mapping:	All color entries are reset to the position on which they were taught.

Object 2812h: Color table edit

2812	RECORD	Color table edit			
------	--------	------------------	--	--	--

Subindices

0	VAR	Number of entries	3	Unsigned8	ro
1	VAR	Color delete	0x00(0)	Unsigned8	rw
2	VAR	Reset color table	FALSE	BOOL	rw
3	VAR	New color	0x00(0)	Unsigned8	rw
4	VAR	Teach color	FALSE	BOOL	rw

Color delete:	Specifies the number of the color to be deleted from the color table.
Reset color table:	Reset the color table to factory settings.
New color:	Creating a new color in the color table. Then the new created color („Edit color name“) is to edit in the 2810h “Color entry“ object.
Teach color:	Teach a new color

Object 2815h: Color detection threshold

2815	RECORD	Threshold entry			ro
------	--------	-----------------	--	--	----

Subindices

0	VAR	Number of entries	3	Unsigned8	ro
1	VAR	Delta 1	1.0	FLOAT32	rw
2	VAR	Delta 2	1.0	FLOAT32	rw
3	VAR	Delta 3	1.0	FLOAT32	rw

Object 2816h: Limit value selection

2816	RECORD	Threshold selection			ro
------	--------	---------------------	--	--	----

Subindices

0	VAR	Number of entries	2	Unsigned8	ro
1	VAR	Color ids	1, 2, 3,	Visible String	rw
2	VAR	Selected color for edit	0x01(1)	Unsigned8	rw

Object 603Fh: Sensor error

603F	RECORD	Sensor error			ro
------	--------	--------------	--	--	----

Subindices

0	VAR	Number of entries	2	Unsigned8	ro
1	VAR	Sensor error number	x	Unsigned16	ro
2	VAR	Sensor error description	x	Visible String	ro

Further details can be found in the section Error Messages, see Chap. [A 3.10](#).

Sensor error number: Output of the sensor error in communication

Sensor error description: Sensor error as plain text

Object 6060h: System values

6060	RECORD	System values			ro
------	--------	---------------	--	--	----

Subindices

0	VAR	Number of entries	11	Unsigned8	ro
1	VAR	Frequency select	x	Unsigned32	ro
2	VAR	Shutter select	x	Unsigned32	ro
3	VAR	Line temperature	x	Unsigned32	ro
4	VAR	Light sensor temperature	x	Unsigned32	ro
5	VAR	Light sensor brightness channel	x	Unsigned32	ro
6	VAR	Light sensor blue channel	x	Unsigned32	ro
7	VAR	Light sensor green channel	x	Unsigned32	ro
8	VAR	Light sensor red channel	x	Unsigned32	ro
9	VAR	Value counter	x	Unsigned32	ro
10	VAR	Time stamp	x	Unsigned32	ro
11	VAR	Sensor state	x	Unsigned32	ro

All measurement values except statistics selected under 21B0h Digital interfaces object.

Object 6065h: XYZ color value

6065	RECORD	XYZ color values			ro
------	--------	------------------	--	--	----

Subindices

0	VAR	Number of entries	3	Unsigned8	ro
1	VAR	XYZ color values X	x	Unsigned 32	ro
2	VAR	XYZ color values Y	x	Unsigned 32	ro
3	VAR	XYZ color values Z	x	Unsigned 32	ro

Object 6066h: RGB color values

6066	RECORD	RGB color values			ro
------	--------	------------------	--	--	----

Subindices

0	VAR	Number of entries	3	Unsigned8	ro
1	VAR	RGB color values R	x	Unsigned 32	ro
2	VAR	RGB color values G	x	Unsigned 32	ro
3	VAR	RGB color values B	x	Unsigned 32	ro

Object 6067h: L*a*b* color values

6067	RECORD	L*a*b* color values			ro
------	--------	---------------------	--	--	----

Subindices

0	VAR	Number of entries	3	Unsigned8	ro
1	VAR	L*a*b* color values L*	x	Signed32	ro
2	VAR	L*a*b* color values a*	x	Signed32	ro
3	VAR	L*a*b* color values b*	x	Signed32	ro

Object 6068h: L*u*v* color values

6068	RECORD	L*u*v* color values			ro
------	--------	---------------------	--	--	----

Subindices

0	VAR	Number of entries	3	Unsigned8	ro
1	VAR	L*u*v* color values L*	x	Signed32	ro
2	VAR	L*u*v* color values u*	x	Signed32	ro
3	VAR	L*u*v* color values v*	x	Signed32	ro

Object 6069h: L*C*h° color values

6069	RECORD	L*C*h° color values			ro
------	--------	---------------------	--	--	----

Subindices

0	VAR	Number of entries	3	Unsigned8	ro
1	VAR	L*C*h° color values L*	x	Signed32	ro
2	VAR	L*C*h° color values C*	x	Signed32	ro
3	VAR	L*C*h° color values h°	x	Signed32	ro

Object 606Ah: Lab99 color values

606A	RECORD	Lab99 color values			ro
------	--------	--------------------	--	--	----

Subindices

0	VAR	Number of entries	3	Unsigned8	ro
1	VAR	Lab99 color values L99	x	Signed32	ro
2	VAR	Lab99 color values a99	x	Signed32	ro
3	VAR	Lab99 color values b99	x	Signed32	ro

Object 606Bh: LCh99 color values

606B	RECORD	System values			ro
------	--------	---------------	--	--	----

Subindices

0	VAR	LCh99 color values	3	Unsigned8	ro
1	VAR	LCh99 color values L99	x	Signed32	ro
2	VAR	LCh99 color values C99	x	Signed32	ro
3	VAR	LCh99 color values h99	x	Signed32	ro

Object 6080h: Color distance no. 1

6080	RECORD	Color distance no. 1			ro
------	--------	----------------------	--	--	----

Subindices

0	VAR	Number of entries	5	Unsigned8	ro
1	VAR	Color distance no. 1 L*	x	Signed32	ro
2	VAR	Color distance no. 1 a*	x	Signed32	ro
3	VAR	Color distance no. 1 b*	x	Signed32	ro
4	VAR	Color distance no. 1 ab*	x	Signed32	ro
5	VAR	Color distance no. 1 E	x	Signed32	ro

Object 6081h: Color distance no. 2

6081	RECORD	Color distance no. 2			ro
------	--------	----------------------	--	--	----

Subindices

0	VAR	Number of entries	5	Unsigned8	ro
1	VAR	Color distance no. 2 L*	x	Signed32	ro
2	VAR	Color distance no. 2 a*	x	Signed32	ro
3	VAR	Color distance no. 2 b*	x	Signed32	ro
4	VAR	Color distance no. 2 ab*	x	Signed32	ro
5	VAR	Color distance no. 2 E	x	Signed32	ro

Object 6082h: Color distance no. 3

6082	RECORD	Color distance no. 3			ro
------	--------	----------------------	--	--	----

Subindices

0	VAR	Number of entries	5	Unsigned8	ro
1	VAR	Color distance no. 3 L*	x	Signed32	ro
2	VAR	Color distance no. 3 a*	x	Signed32	ro
3	VAR	Color distance no. 3 b*	x	Signed32	ro
4	VAR	Color distance no. 3 ab*	x	Signed32	ro
5	VAR	Color distance no. 3 E	x	Signed32	ro

Object 6083h: Color distance no. 4

6083	RECORD	Color distance no. 4			ro
------	--------	----------------------	--	--	----

Subindices

0	VAR	Number of entries	5	Unsigned8	ro
1	VAR	Color distance no. 4 L*	x	Signed32	ro
2	VAR	Color distance no. 4 a*	x	Signed32	ro
3	VAR	Color distance no. 4 b*	x	Signed32	ro
4	VAR	Color distance no. 4 ab*	x	Signed32	ro
5	VAR	Color distance no. 4 E	x	Signed32	ro

Object 6084h: Color distance no. 5

6084	RECORD	Color distance no. 5			ro
------	--------	----------------------	--	--	----

Subindices

0	VAR	Number of entries	5	Unsigned8	ro
1	VAR	Color distance no. 5 L*	x	Signed32	ro
2	VAR	Color distance no. 5 a*	x	Signed32	ro
3	VAR	Color distance no. 5 b*	x	Signed32	ro
4	VAR	Color distance no. 5 ab*	x	Signed32	ro
5	VAR	Color distance no. 5 E	x	Signed32	ro

Object 6085h: Color distance no. 6

6085	RECORD	Color distance no. 6			ro
------	--------	----------------------	--	--	----

Subindices

0	VAR	Number of entries	5	Unsigned8	ro
1	VAR	Color distance no. 6 L*	x	Signed32	ro
2	VAR	Color distance no. 6 a*	x	Signed32	ro
3	VAR	Color distance no. 6 b*	x	Signed32	ro
4	VAR	Color distance no. 6 ab*	x	Signed32	ro
5	VAR	Color distance no. 6 E	x	Signed32	ro

Object 6086h: Color distance no. 7

6086	RECORD	Color distance no. 7			ro
------	--------	----------------------	--	--	----

Subindices

0	VAR	Number of entries	5	Unsigned8	ro
1	VAR	Color distance no. 7 L*	x	Signed32	ro
2	VAR	Color distance no. 7 a*	x	Signed32	ro
3	VAR	Color distance no. 7 b*	x	Signed32	ro
4	VAR	Color distance no. 7 ab*	x	Signed32	ro
5	VAR	Color distance no. 7 E	x	Signed32	ro

Object 6087h: Color distance no. 8

6087	RECORD	Color distance no. 8			ro
------	--------	----------------------	--	--	----

Subindices

0	VAR	Number of entries	5	Unsigned8	ro
1	VAR	Color distance no. 8 L*	x	Signed32	ro
2	VAR	Color distance no. 8 a*	x	Signed32	ro
3	VAR	Color distance no. 8 b*	x	Signed32	ro
4	VAR	Color distance no. 8 ab*	x	Signed32	ro
5	VAR	Color distance no. 8 E	x	Signed32	ro

Object 6088h: Color distance no. 9

6088	RECORD	Color distance no. 9			ro
------	--------	----------------------	--	--	----

Subindices

0	VAR	Number of entries	5	Unsigned8	ro
1	VAR	Color distance no. 7 L*	x	Signed32	ro
2	VAR	Color distance no. 6 a*	x	Signed32	ro
3	VAR	Color distance no. 6 b*	x	Signed32	ro
4	VAR	Color distance no. 6 ab*	x	Signed32	ro
5	VAR	Color distance no. 6 E	x	Signed32	ro

Object 6089h: Color distance no. 10

6089	RECORD	Color distance no. 10			ro
------	--------	-----------------------	--	--	----

Subindices

0	VAR	Number of entries	5	Unsigned8	ro
1	VAR	Color distance no. 10 L*	x	Signed32	ro
2	VAR	Color distance no. 10 a*	x	Signed32	ro
3	VAR	Color distance no. 10 b*	x	Signed32	ro
4	VAR	Color distance no. 10 ab*	x	Signed32	ro
5	VAR	Color distance no. 10 E	x	Signed32	ro

Object 608Ah: Color distance no. 11

608A	RECORD	Color distance no. 11			ro
------	--------	-----------------------	--	--	----

Subindices

0	VAR	Number of entries	5	Unsigned8	ro
1	VAR	Color distance no. 11 L*	x	Signed32	ro
2	VAR	Color distance no. 11 a*	x	Signed32	ro
3	VAR	Color distance no. 11 b*	x	Signed32	ro
4	VAR	Color distance no. 11 ab*	x	Signed32	ro
5	VAR	Color distance no. 11 E	x	Signed32	ro

Object 608Bh: Color distance no. 12

608B	RECORD	Color distance no. 12			ro
------	--------	-----------------------	--	--	----

Subindices

0	VAR	Number of entries	5	Unsigned8	ro
1	VAR	Color distance no. 12 L*	x	Signed32	ro
2	VAR	Color distance no. 12 a*	x	Signed32	ro
3	VAR	Color distance no. 12 b*	x	Signed32	ro
4	VAR	Color distance no. 12 ab*	x	Signed32	ro
5	VAR	Color distance no. 12 E	x	Signed32	ro

Object 608Ch: Color distance no. 13

608C	RECORD	Color distance no. 13			ro
------	--------	-----------------------	--	--	----

Subindices

0	VAR	Number of entries	5	Unsigned8	ro
1	VAR	Color distance no. 13 L*	x	Signed32	ro
2	VAR	Color distance no. 13 a*	x	Signed32	ro
3	VAR	Color distance no. 13 b*	x	Signed32	ro
4	VAR	Color distance no. 13 ab*	x	Signed32	ro
5	VAR	Color distance no. 13 E	x	Signed32	ro

Object 608Dh: Color distance no. 14

608D	RECORD	Color distance no. 14			ro
------	--------	-----------------------	--	--	----

Subindices

0	VAR	Number of entries	5	Unsigned8	ro
1	VAR	Color distance no. 14 L*	x	Signed32	ro
2	VAR	Color distance no. 14 a*	x	Signed32	ro
3	VAR	Color distance no. 14 b*	x	Signed32	ro
4	VAR	Color distance no. 14 ab*	x	Signed32	ro
5	VAR	Color distance no. 14 E	x	Signed32	ro

Object 608Eh: Color distance no. 15

608E	RECORD	Color distance no. 15			ro
------	--------	-----------------------	--	--	----

Subindices

0	VAR	Number of entries	5	Unsigned8	ro
1	VAR	Color distance no. 15 L*	x	Signed32	ro
2	VAR	Color distance no. 15 a*	x	Signed32	ro
3	VAR	Color distance no. 15 b*	x	Signed32	ro
4	VAR	Color distance no. 15 ab*	x	Signed32	ro
5	VAR	Color distance no. 15 E	x	Signed32	ro

Object 608Fh: Color distance no. 16

608F	RECORD	Color distance no. 16			ro
------	--------	-----------------------	--	--	----

Subindices

0	VAR	Number of entries	5	Unsigned8	ro
1	VAR	Color distance no. 16 L*	x	Signed32	ro
2	VAR	Color distance no. 16 a*	x	Signed32	ro
3	VAR	Color distance no. 16 b*	x	Signed32	ro
4	VAR	Color distance no. 16 ab*	x	Signed32	ro
5	VAR	Color distance no. 16 E	x	Signed32	ro

Object 60C0h: Statistic for color value component 1

60C0	RECORD	Statistic for color value comp. 1			ro
------	--------	-----------------------------------	--	--	----

Subindices

0	VAR	Number of entries	5	Unsigned8	ro
1	VAR	Statistic value min (X, R, L, L99)	x	Un-/Signed32	ro
2	VAR	Statistic value max (X, R, L, L99)	x	Un-/Signed32	ro
3	VAR	Statistic value peak-peak (X, R, L, L99)	x	Un-/Signed32	ro

Object 60C1h: Statistic for color value component 2

60C1	RECORD	Statistic for color value comp. 2			ro
------	--------	-----------------------------------	--	--	----

Subindices

0	VAR	Number of entries	5	Unsigned8	ro
1	VAR	Statistic value min (Y, G, a*, u*, C*, a99, C99)	x	Un-/Signed32	ro
2	VAR	Statistic value max (Y, G, a*, u*, C*, a99, C99)	x	Un-/Signed32	ro
3	VAR	Statistic value peak-peak (Y, G, a*, u*, C*, a99, C99)	x	Un-/Signed32	ro

Object 60C2h: Statistic for color value component 3

60C2	RECORD	Statistic for color value comp. 3			ro
------	--------	-----------------------------------	--	--	----

Subindices

0	VAR	Number of entries	5	Unsigned8	ro
1	VAR	Statistic value min (Z, B, b*, v*, h°, b99, h99)	x	Un-/Signed32	ro
2	VAR	Statistic value max (Z, B, b*, v*, h°, b99, h99)	x	Un-/Signed32	ro
3	VAR	Statistic value peak-peak (Z, B, b*, v*, h°, b99, h99)	x	Un-/Signed32	ro

Object 60E0h: Statistic for color dist. (no. n / best-hit) L*

60E0	RECORD	Statistic for color dist. (no. n / best-hit) L*			ro
------	--------	---	--	--	----

Subindices

0	VAR	Number of entries	5	Unsigned8	ro
1	VAR	Statistic value min L*	x	Signed32	ro
2	VAR	Statistic value max L*	x	Signed32	ro
3	VAR	Statistic value peak-peak L*	x	Signed32	ro

Object 60E1h: Statistic for color dist. (no. n / best-hit) a*

60E1	RECORD	Statistic for color dist. (no. n / best-hit) a*			ro
------	--------	---	--	--	----

Subindices

0	VAR	Number of entries	5	Unsigned8	ro
1	VAR	Statistic value min a*	x	Signed32	ro
2	VAR	Statistic value max a*	x	Signed32	ro
3	VAR	Statistic value peak-peak a*	x	Signed32	ro

Object 60E2h: Statistic for color dist. (no. n / best-hit) L*

60E2	RECORD	Statistic for color dist. (no. n / best-hit) b*			ro
------	--------	---	--	--	----

Subindices

0	VAR	Anzahl Einträge	5	Unsigned8	ro
1	VAR	Statistic value min b*	x	Signed32	ro
2	VAR	Statistic value max b*	x	Signed32	ro
3	VAR	Statistic value peak-peak b*	x	Signed32	ro

Object 60E3h: Statistic for color dist. (no. n / best-hit) ab*

60E3	RECORD	Statistic for color dist. (no. n / best-hit) ab*			
------	--------	--	--	--	--

Subindices

0	VAR	Number of entries	5	Unsigned8	ro
1	VAR	Statistic value min ab*	x	Signed32	ro
2	VAR	Statistic value max ab*	x	Signed32	ro
3	VAR	Statistic value peak-peak ab*	x	Signed32	ro

Object 60E4h: Statistic for color dist. (no. n / best-hit) E*

60E4	RECORD	Statistic for color dist. (no. n / best-hit) E			ro
------	--------	--	--	--	----

Subindices

0	VAR	Number of entries	5	Unsigned8	ro
1	VAR	Statistic value min E	x	Signed32	ro
2	VAR	Statistic value max E	x	Signed32	ro
3	VAR	Statistic value peak-peak E	x	Signed32	ro

Object 60E5h: Stat. number of (detected color / color with min. distance)

60E5	RECORD	Stat. number of (detected color / color with min. distance)	ro
------	--------	---	----

Subindices

0	VAR	Number of entries	5	Unsigned8	ro
1	VAR	Statistic value min	x	Signed32	ro
2	VAR	Statistic value max	x	Signed32	ro
3	VAR	Statistic value peak-peak	x	Signed32	ro

A 4.3 Error Codes for SDO Services

In case of a negative evaluation of a SDO requirement, a corresponding error code is output in "Abort SDO Transfer Protocol".

Error code hexadecimal	Meaning
0503 0000	Toggle-Bit has not changed.
0504 0000	SDO protocol timeout expired
0504 0001	Invalid command registered
0504 0005	Not enough memory
0601 0000	Access to object (parameter) not supported.
0601 0001	Attempt to write to a "read-only parameter"
0601 0002	Attempt to write to a "read-only parameter"
0602 0000	Object (parameter) is not listed in the object directory.
0604 0041	Object (parameter) is not mapped on PDO
0604 0042	Number or length of objects to be transmitted exceeds PDO length.
0604 0043	General parameters incompatibility
0604 0047	General internal device incompatibility
0606 0000	Excess denied because of a hardware error
0607 0010	False data type or length of service parameter is incorrect.
0607 0012	False data type or length of service parameter is too large.
0607 0013	False data type or length of service parameter is too small.
0609 0011	Subindex does not exist
0609 0030	Invalid value of parameter (only for write access)
0609 0031	Value of the parameter too large
0609 0032	Value of the parameter too small
0609 0036	Maximum value exceeds minimum value.
0800 0000	General error
0800 0020	Data can not be transmitted or saved in application.
0800 0021	Data can not be transmitted or saved in application, because of local control.
0800 0022	Data can not be transmitted or saved in application, because device state.
0800 0023	Dynamic generation of object directory failed or no object directory is available

A 4.4 Data Formats

The data formats are similar to those in Ethernet mode. See the section Measured Value Format, see Chap. A 3.8.

A 4.5 Distributed Clock

A 4.5.1 Introduction

The synchronization of ACS7000 among each other in the EtherCAT is realized via the Distributed Clock.

With it it is not necessary or possible to transmit the synchronous input or output of the controller.

Unlike the Ethernet the synchronization does not occur via external signals but about the clocks in the controllers. Using the EtherCAT this results in the synchronous modes `Synchronization out` (= Free Run) and `Slave`.

The minimum cycle time for distributed clock is 500 μ s.

A 4.5.2 Synchronization

ACS7000, that support the synchronization in the EtherCAT mode, offer the additional tab `DC` in the TwinCat-Manager. In addition to the `FreeRun` mode (not synchronized), the controller can be operated synchronously with different frequencies.

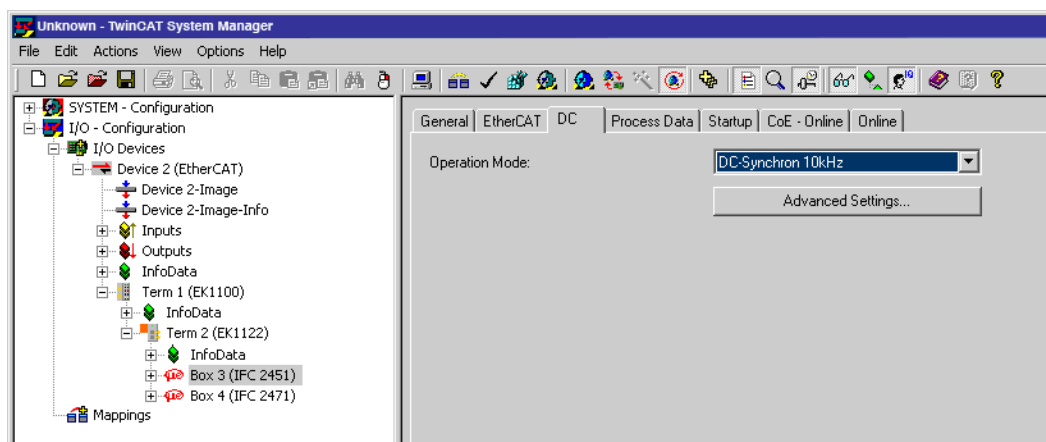

A 4.5.3 Synchronization off

In the `FreeRun` mode no synchronization of controllers occurs.

A 4.5.4 Slave

In the `DC-Synchron xxxkHz` and `DC-Synchron manuel` mode the controller is switched in the synchronization mode `Slave`.

For the measurement frequency to be defined manually, the measurement time must be specified in μ s:

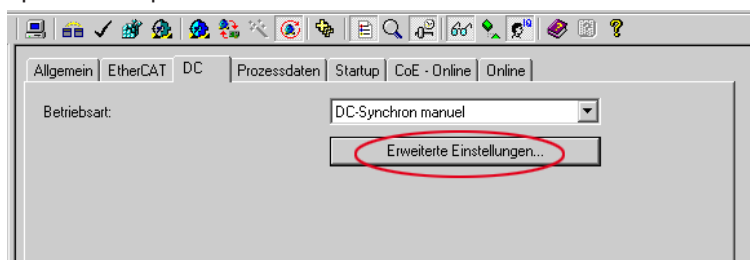

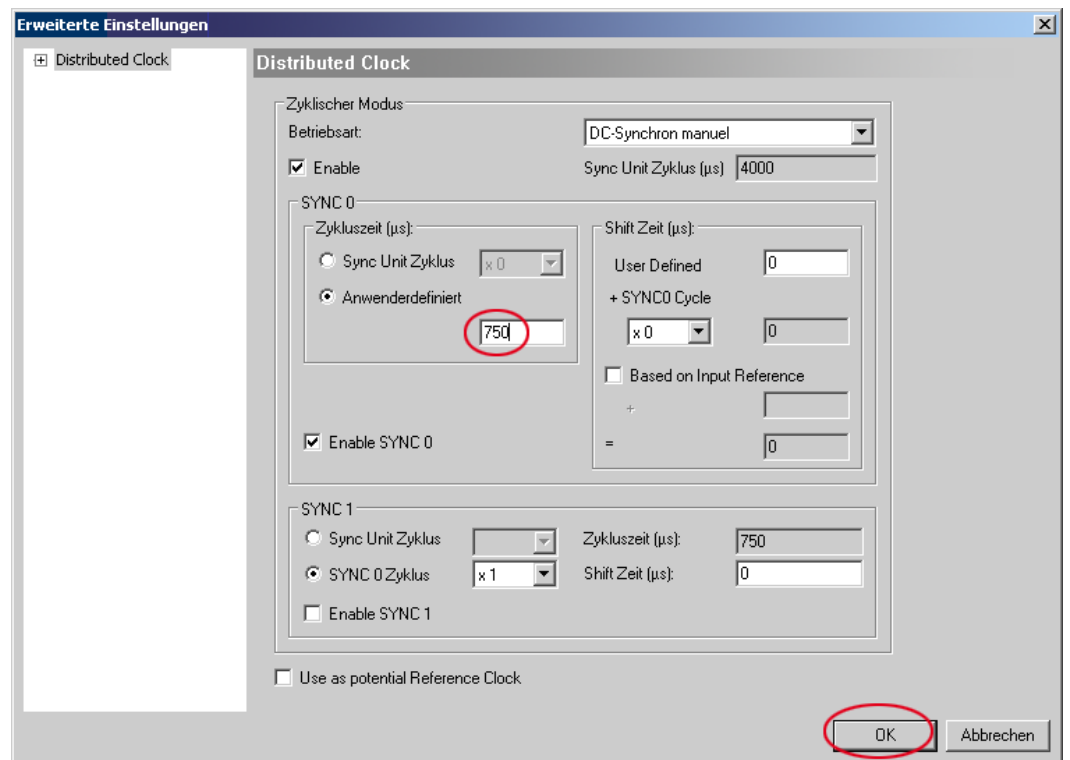

A 4.5.5 Apply Selected Settings

Once the required synchronization mode is selected using the drop-down-menu, it is applied with F4.

A 4.5.6 Setting Regardless of TwinCat

The setting of the synchronization mode in EtherCAT occurs via the setting of the registers for the Distributed Clocks. You will find details under www.beckhoff.de or www.ethercat.org. For reading the settings in the TwinCAT it is possible to display the requirements of the XML file using the button `Advanced Settings`.

A 4.6 Meaning of STATUS-LED in EtherCAT Operation

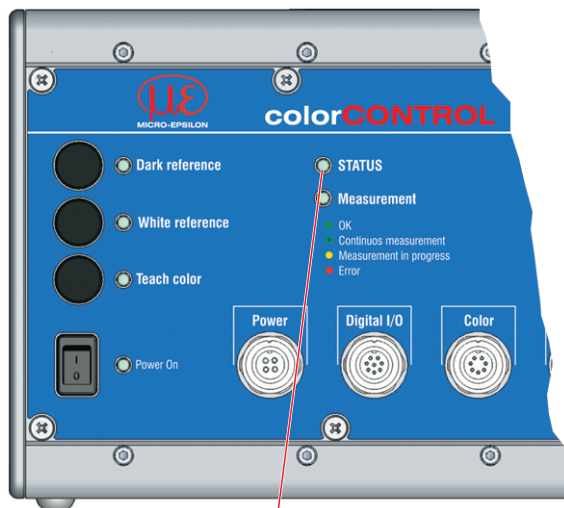

Status LED

Green	
Green off	INIT status
Green flashing 2.5 Hz	PRE-OP status
Green Single Flash, 200 ms ON / 1000 ms OFF	SAFE-OP status
Green on	OP status
Red (are displayed in the breaks of the green LED)	
Red off	No error
Red flashing 2.5 Hz	Invalid configuration
Red Single Flash, 200 ms ON / 1000 ms OFF	Not requested status change
Red Double Flash, 200 ms ON / 200 ms OFF / 200 ms ON / 400 ms OFF	Timeout of the watchdog
Red flashing 10 Hz	Error by initializing

A 4.7 EtherCAT Configuration with the Beckhoff TwinCAT® Manager

For example the Beckhoff TwinCAT Manager can be used as EtherCAT Master on the PC.

- Copy the device description file (EtherCAT®-Slave-Information) `colorCONTROLACS7000.xml` from the included CD in the directory `\\TwinCAT\IO\EtherCAT` before the measuring device can be configured via EtherCAT®.

EtherCAT®-Slave information files are XML files, which specify the characteristics of the Slave device for the EtherCAT® Master and contain informations to the supported communication objects.

- Restart the TwinCAT Manager after copying.

Searching for a device:

- Select the tab I/O Devices, then Scan devices.
- Confirm with OK.

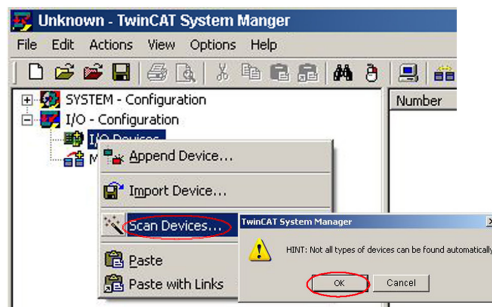

- Select a network card, where EtherCAT®-Slaves should be searched.



It appears the window Scan for boxes (EtherCAT®-Slaves).

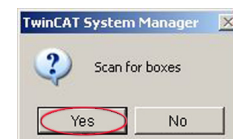

- Confirm with OK.

- Confirm with Yes.

The ACS7000 is now shown in a list.

- Now confirm the window Activate Free Run with Yes.

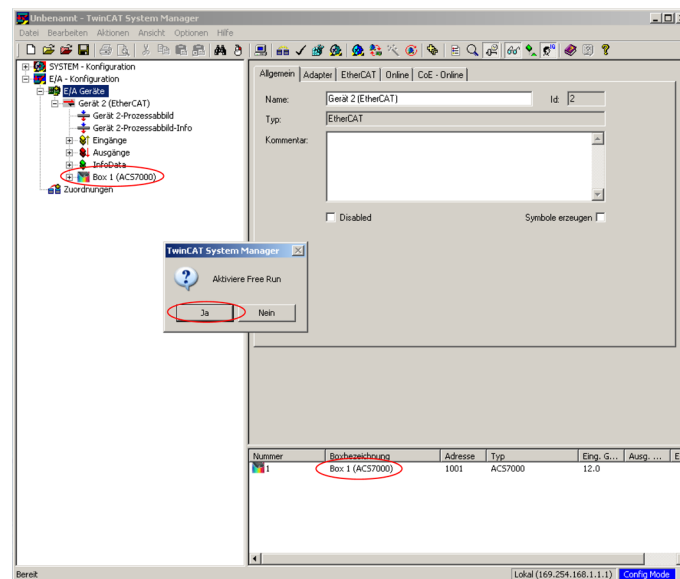

The current status should be at least PREOP, SAFEOP or OP on the ONLINE side.

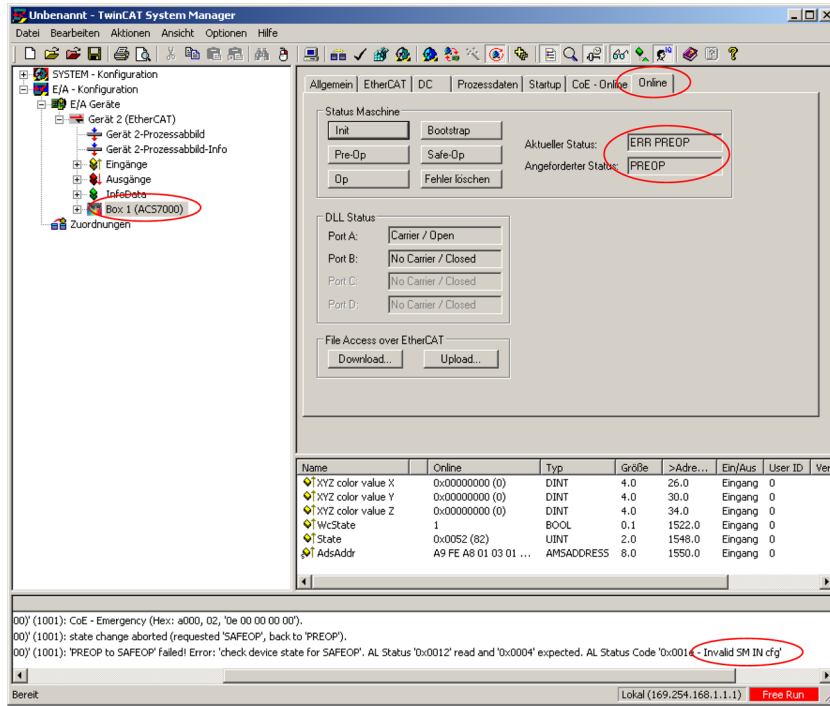

If ERP PREOP appears in the `Current State`, the cause is reported in the message window. In the example here the incorrect initialization of the synchronization manager is the reason. This will be the case if the settings for the PDO mapping in the sensor are different from the settings in the ESI file (colorCONTROLACS7000.xml).

On delivery of the sensor only one measurement value (Color value XYZ) is set as output size (in both the sensor and in the ESI file).

To configure the synchronous manager correctly, it is first necessary to read the object directory of ACS7000.

Select Mappable Objects (TxPDO) .

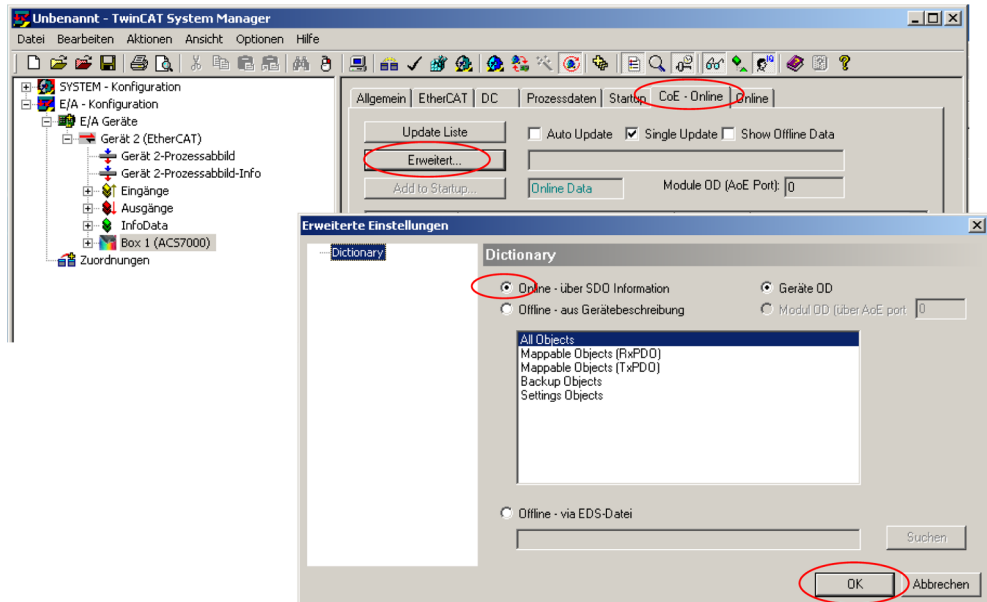

➡ Confirm with OK .

Example for a complete object directory (subject to change without prior notice).

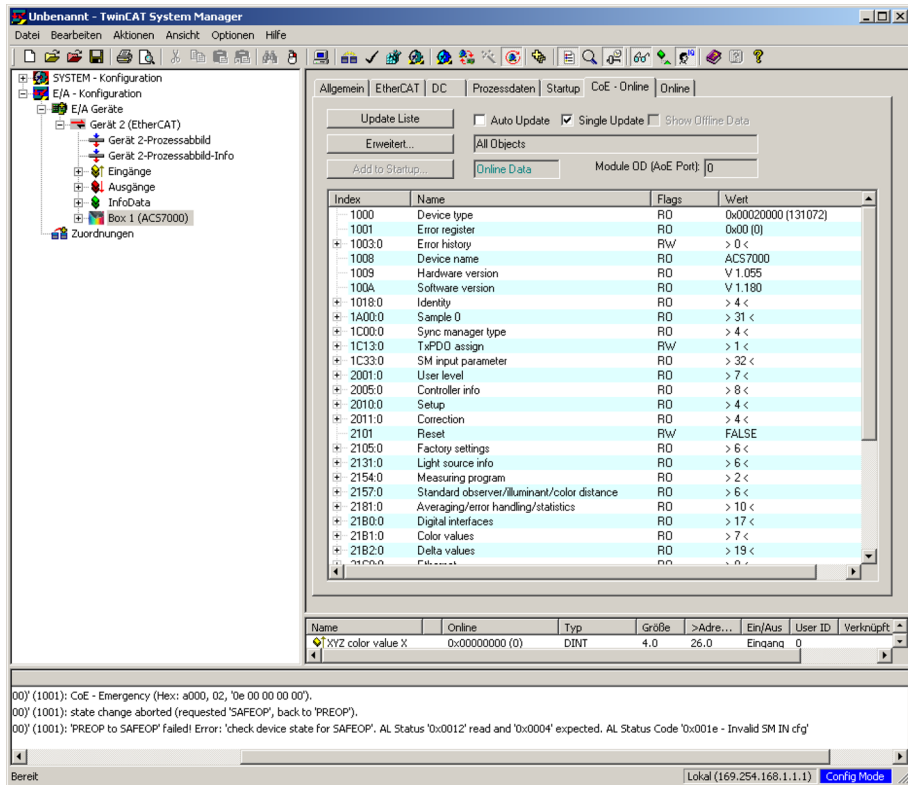

On the Process data side the PDO allocations can be read from the device.

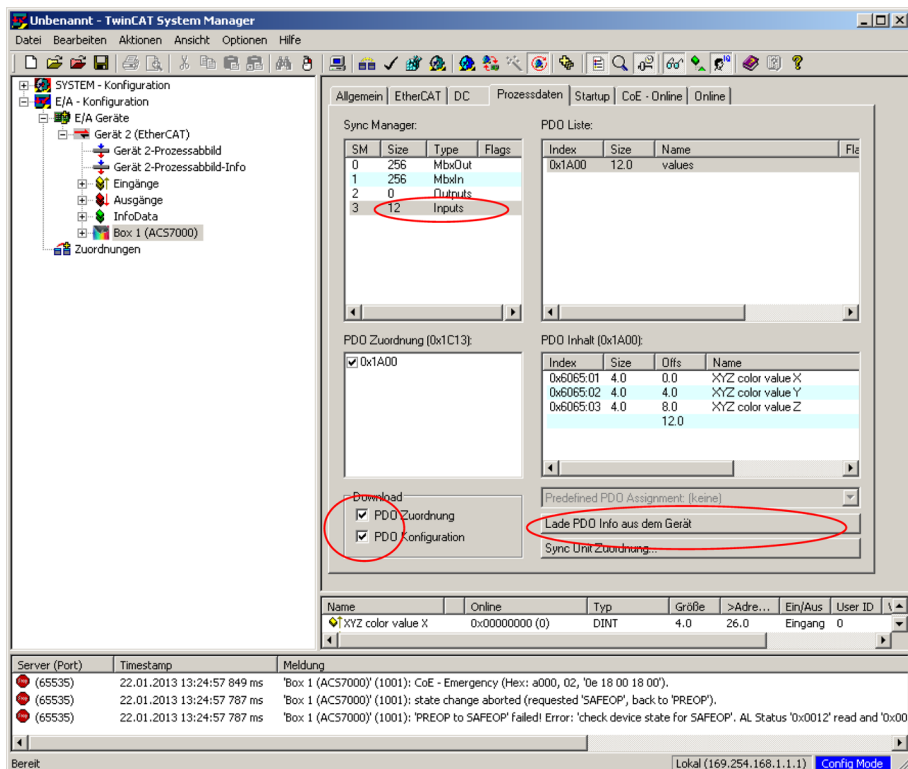

The scope of the provided process data and the assignment of the SyncManager may be viewed now.

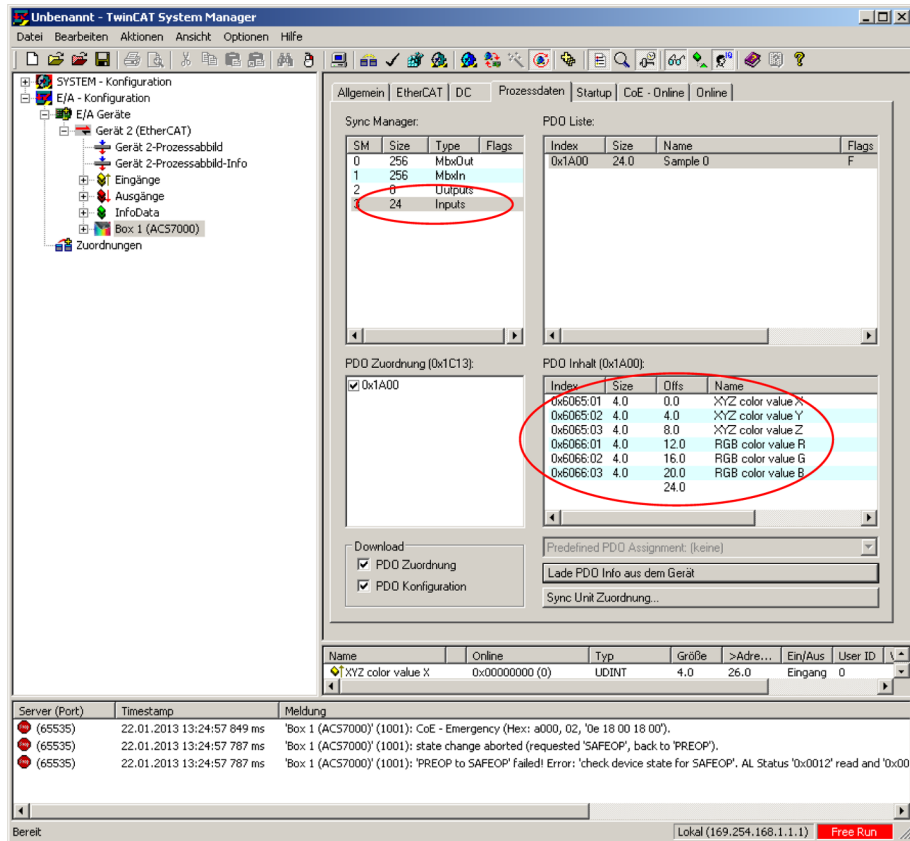

➡ Change to the page CoE online, if you add or remove more process data for output. Open the objects 0x21B0, 0x21B1 and 0x21B2:

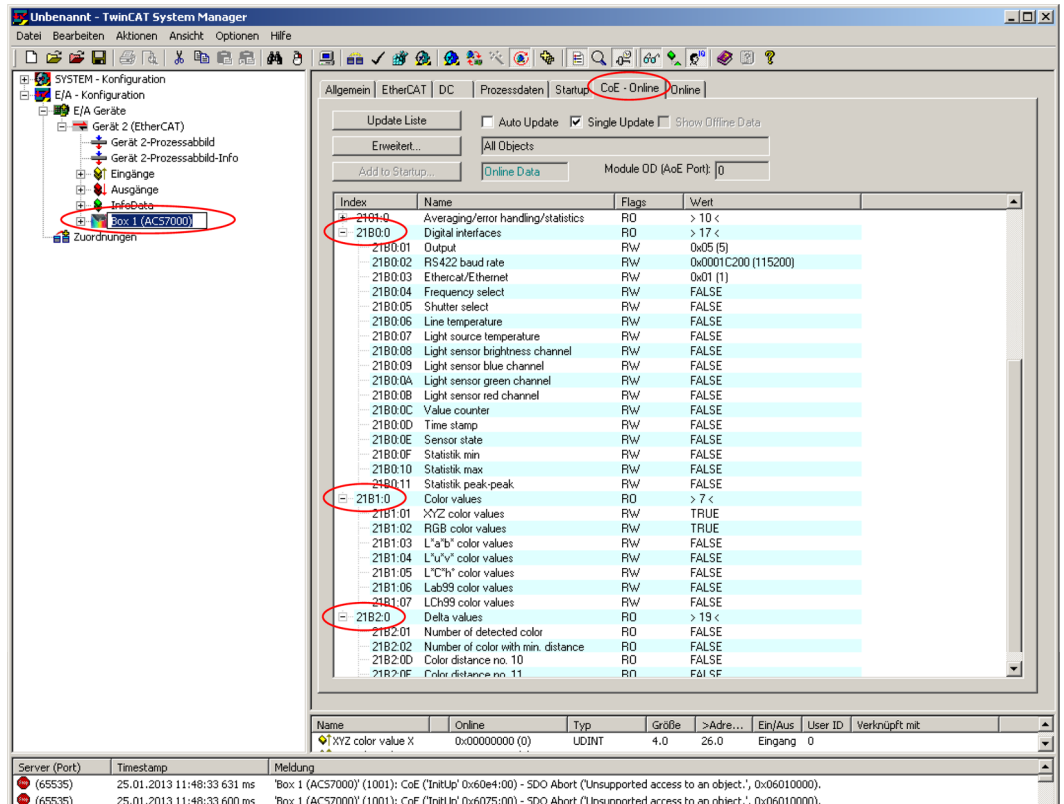

You can make your desired selection of process data according to the selected measurement program (color measurement / color detection).

i To select statistic values, a measured value about which the statistics should be conducted must be set in the 0x21B1.0A "Signal for statistics" object. See object description Averaging, error processing and statistics, see Chap. [A 4.2.2](#)

2181:0	Averaging/error handling/statistics	RO	> 10 <
2181:01	Measured value averaging type	RW	0x00 (0)
2181:02	Number of values for moving average	RW	0x0002 (2)
2181:03	Number of values for median	RW	0x03 (3)
2181:04	Number of values for recursive average	RW	0x0002 (2)
2181:05	Statistic depth	RW	0x0000 (0)
2181:06	Reset statistic	RW	FALSE
2181:07	Error handling	RW	0
2181:08	Number of held values	RW	0x0000 (0)
2181:09	Video averaging	RW	0x00 (0)
2181:0A	Signal for statistics	RW	4
2180:0	Digital interfaces	RO	> 17 <
2180:01	Output	RW	0x05 (5)
2180:02	RS422 baud rate	RW	0x0001C200 (115200)
2180:03	Ethercat/Ethernet	RW	0x01 (1)
2180:04	Frequency select	RW	FALSE
2180:05	Shutter select	RW	FALSE

The statistic values `Statistic min`, `Statistic max` and `Statistic peak-peak` can be selected only, if a valid measured value (according to selected measuring program) is given in the object `0x2181.0A`.

i Not arbitrarily many measuring values can be taken up (selected) in the PDO-Mapping. Besides, the option in the color difference measurement program is also limited according to selected distance model, see Chap. 5.3.7.

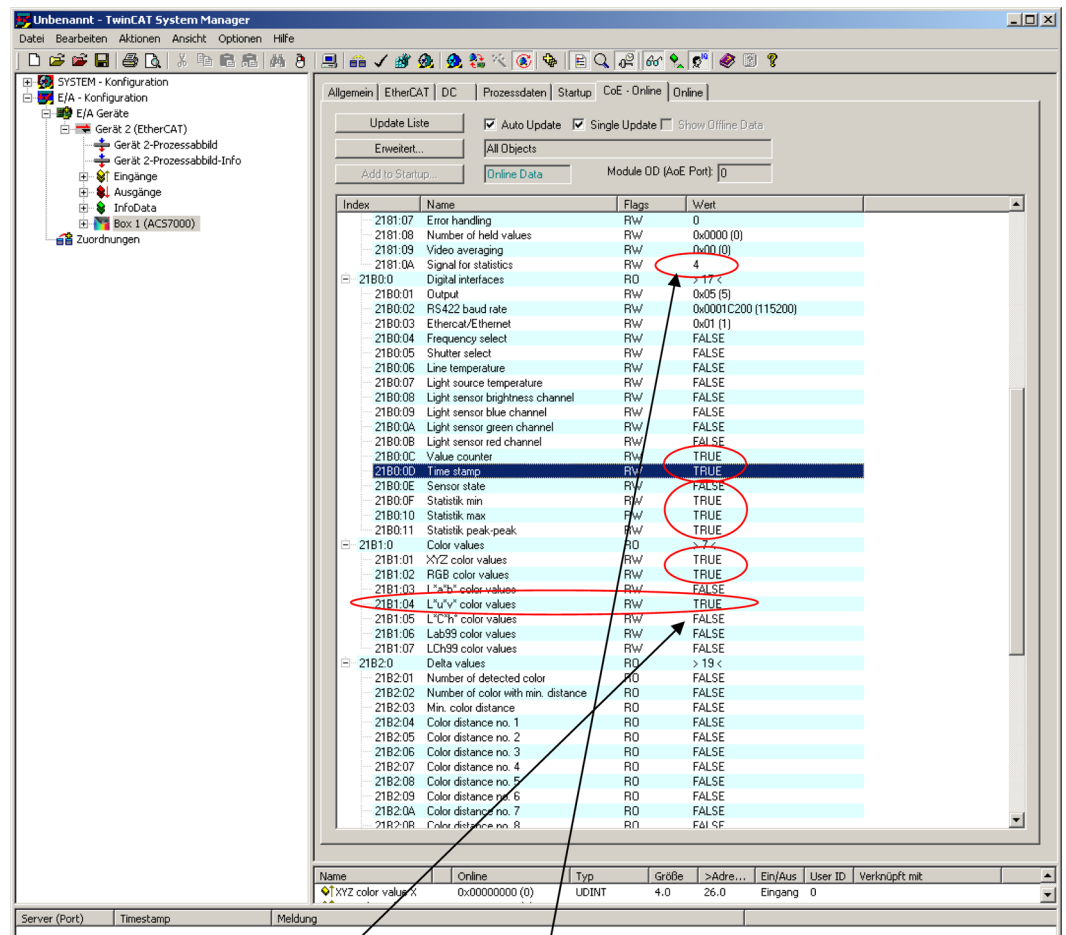

L*u*v* Statistics

The measurement value `L*u*v*` color values was automatically selected because the statistics was selected on this value.

Because the PDO-Mapping is changed by the selection of measurement values, in particular the number of valid subindices of the object `0x1A00`, the object directory must be read anew by the TwinCAT®-Manager.

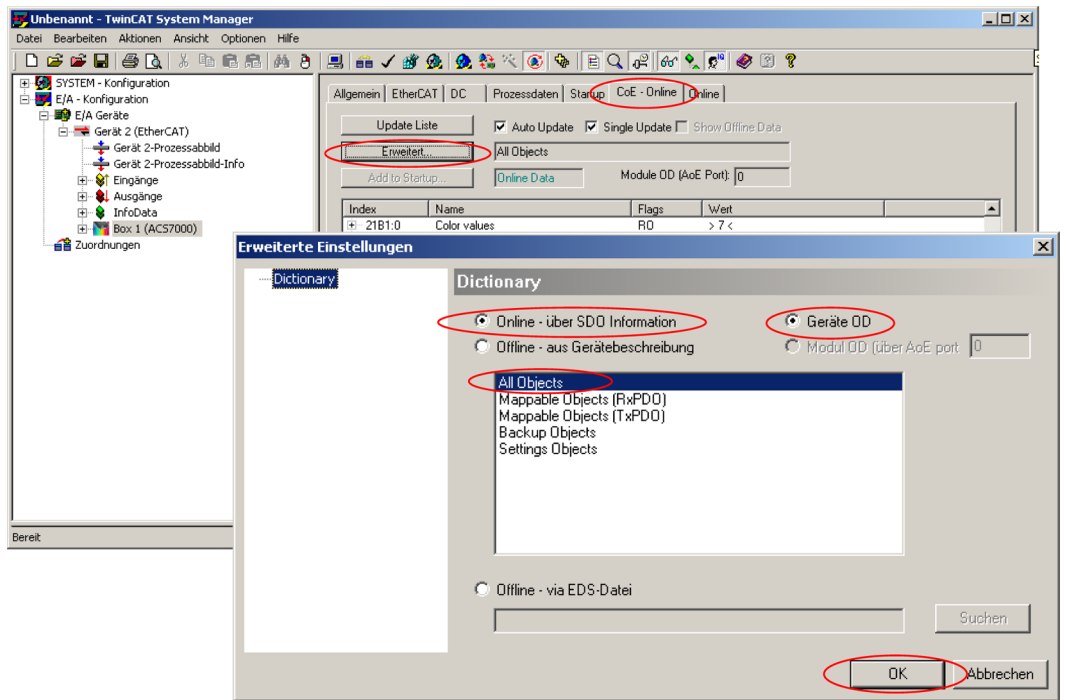

The TwinCAT® Manager displays a rereading by a progress bar. If this bar does not appear, it was not even read. Make briefly another selection in the window Advanced Settings for example Offline - from device description, change the again to Online - about SDA information and click only now on OK.

➡ Change to the tab Process data and click on the button Load PDO Info from the device.

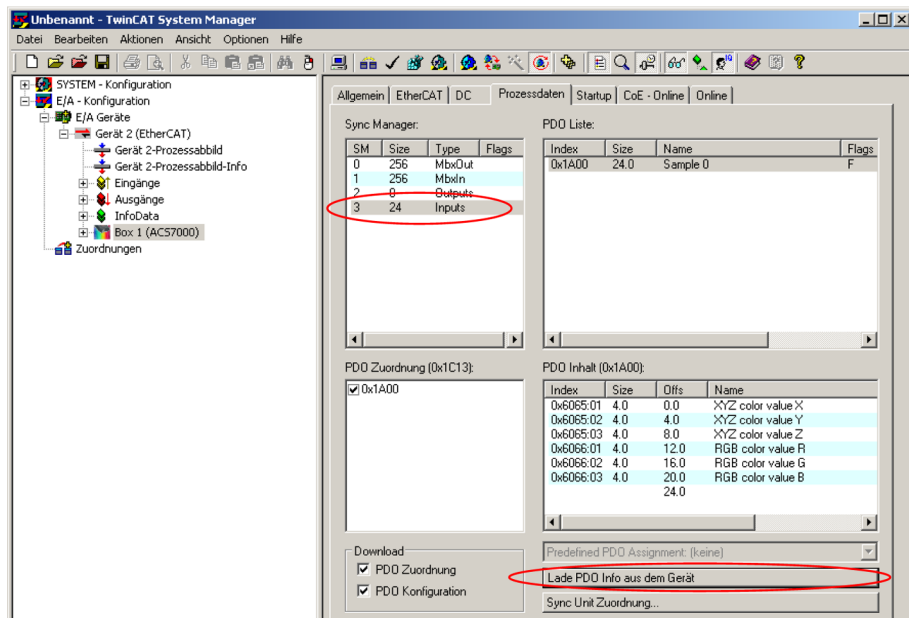

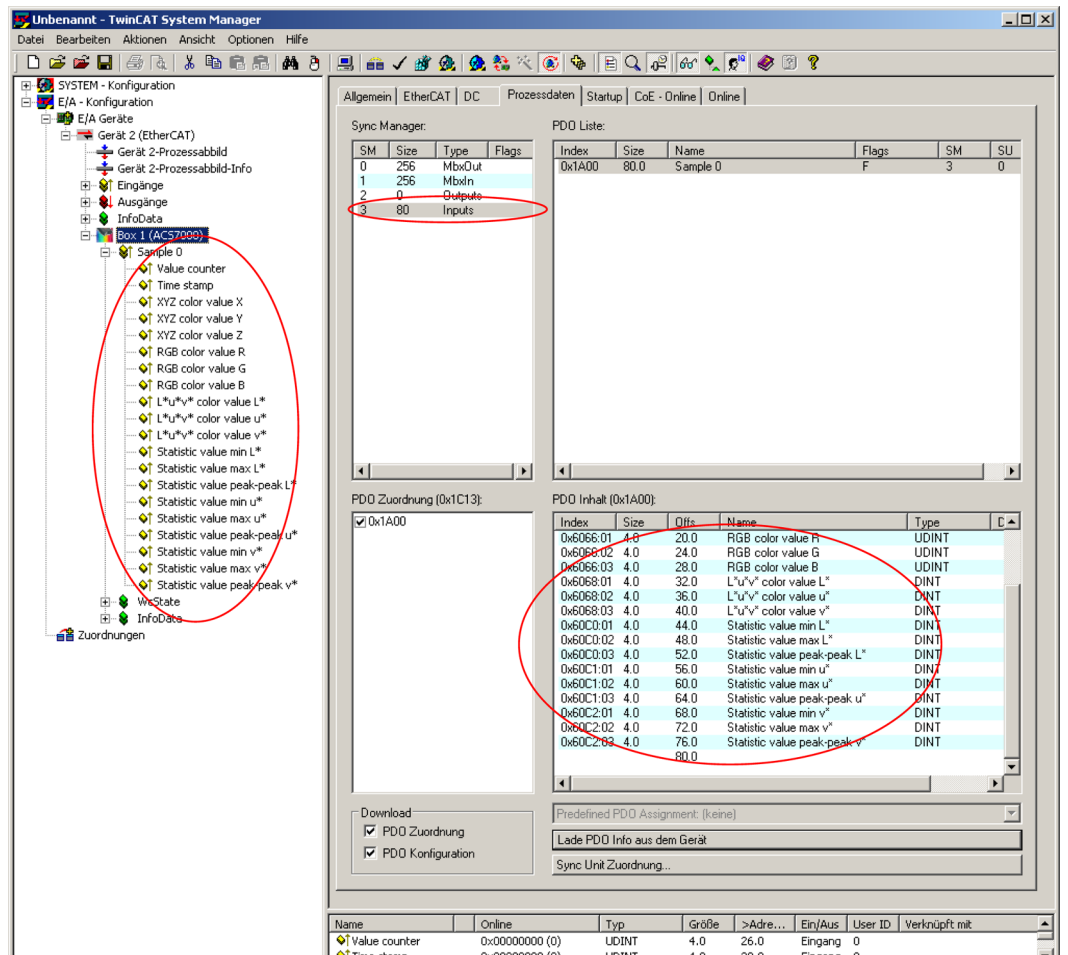

➡ Now select the tab Reload the configuration under the tab Actions.



The configuration is now complete.

The selected measurement values are transmitted as process data in the status SAFEOP and OP.

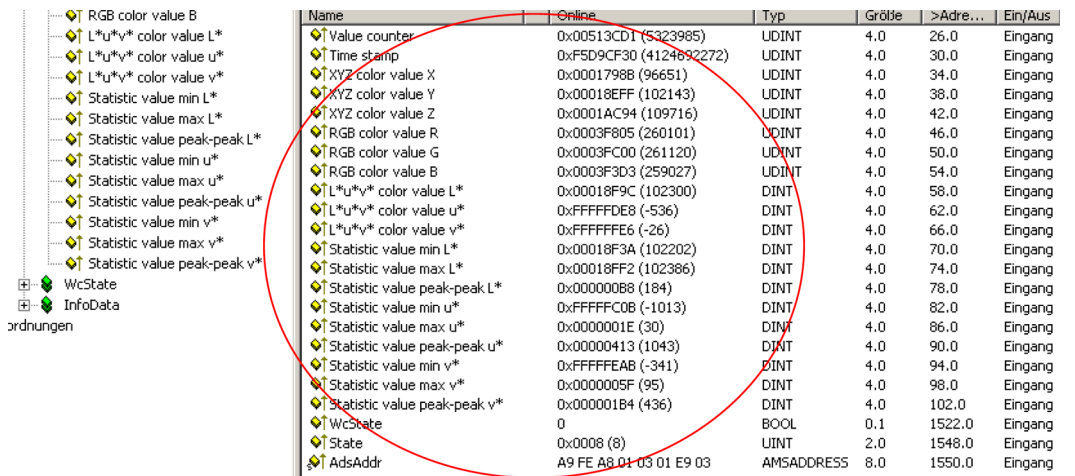

A 5 Terminology

A 5.1 Standard Illuminant

Standard illuminant A: light bulb

Standard illuminant D65: natural daylight; D = daylight, xx = color temperature; e. g. D65: daylight with 6500 K

Standard illuminant C: synthetic daylight from light bulb with filter

Standard illuminant E: no real light source, energetic equivalence point

Standard illuminant F: fluorescent lamps

A 5.2 Standard Observer

In the human eye, “rods” ensure light-dark differentiation (night vision) and “cones” the RGB color vision. The cones are concentrated at the centre of the retina, the rods in the outer regions. Therefore, the colors of large objects in the field of vision (10 °) are perceived more different than small objects (2 °).

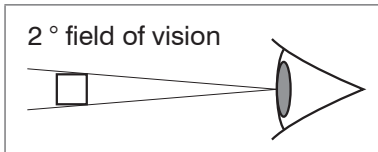
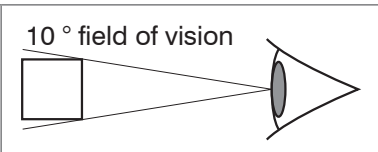
		
Object height	35 mm	175 mm
Observation distance	1 m	

Every person assesses colors in a slightly different way. The CIE defined the normal spectral value function for X (red), Y (green) and Z (blue) on the basis of data determined during a variety of different test series. These functions describe how an average person perceives color.



MICRO-EPSILON Eltrotec GmbH
Manfred-Wörner-Straße 101 · 73037 Göppingen / Germany
Tel. +49 (0) 7161 / 98872-300 · Fax +49 (0) 7161 / 98872-303
eltrotec@micro-epsilon.de · www.micro-epsilon.com

X9751252-A031069SWE

© MICRO-EPSILON MESSTECHNIK

