



Operating Instructions
thermoIMAGER TIM NetPCQ

Mini Industrial PC for TIM series

MICRO-EPSILON
MESSTECHNIK
GmbH & Co. KG
Koenigbacher Str. 15

94496 Ortenburg / Germany

Tel. +49 (0) 8542 / 168-0
Fax +49 (0) 8542 / 168-90
e-mail info@micro-epsilon.com
www.micro-epsilon.com

Contents

1.	Safety	5
1.1	Symbols Used	5
1.2	Warnings	5
1.3	Notes on CE Marking	6
1.4	Intended Use	6
1.5	Proper Environment.....	6
2.	Technical Data	7
2.1	Functional Principle	7
2.2	General Specifications.....	7
2.3	Electrical Specifications.....	8
3.	Delivery	8
3.1	Unpacking, Included in Delivery.....	8
3.2	Storage	8
4.	Mounting and Installation	9
5.	Control Elements and Connections	10
6.	Operation	11
6.1	Operation Modes	11
6.2	Remote Access to the thermoIMAGER TIM NetPCQ.....	11
6.3	Applications and Start Options.....	14
6.3.1	NetBox Control Center	15
6.3.1.1	Select Tab	15
6.3.1.2	Log Tool Tab	17
6.3.1.3	Imager Net Server	19
6.4	File Transfer between thermoIMAGER TIM NetPCQ and PC.....	20
6.5	Direct Ethernet Communication	21
6.6	Connection to the thermoIMAGER TIM NetPC	22
6.7	Ethernet Network Communication	27

6.8	Stand-alone Operation	31
6.9	Write Protection Filter	32
6.10	System Recovery	37
7.	Instructions for Operation.....	44
7.1	Cleaning.....	44
8.	Liability for Material Defects	44
9.	Service, Repair	45
10.	Decommissioning, Disposal	45

1. Safety

System operation assumes knowledge of the operating instructions.

1.1 Symbols Used

The following symbols are used in these operating instructions:



Indicates a hazardous situation which, if not avoided, may result in minor or moderate injury.



Indicates a situation which, if not avoided, may lead to property damage



Indicates a user action.



Indicates a tip for users.

Measure

Indicates hardware or a software button/menu.

1.2 Warnings



Connect the power supply and the display/output device according to the safety regulations for electrical equipment.

- > Risk of injury
- > Damage to or destruction of the PC



Avoid shocks and impacts to the PC.
> Damage to or destruction of the PC

The supply voltage must not exceed the specified limits.

- > Damage to or destruction of the PC

Avoid static electricity and keep away from very strong EMF (electromagnetic fields) e.g. arc welders or induction heaters.

- > Damage to or destruction of the PC

1.3 Notes on CE Marking

The following apply to the thermoIMAGER NetPCQ:

- EU Directive 2014/30/EU
- EU Directive 2014/35/EU
- EU Directive 2011/65/EU, “RoHS” category 11

Products which carry the CE mark satisfy the requirements of the EU directives cited and the relevant applicable harmonized standards (EN). The measuring system is designed for use in industrial and laboratory applications.

The EU Declaration of Conformity is available to the responsible authorities according to EU Directive, article 10.

1.4 Intended Use

- The thermoIMAGER NetPCQ is designed for use in industrial and laboratory applications and is a fanless, passively cooled, industrial PC.
- The system must only be operated within the limits specified in the technical data, [see 2](#).
- The system must be used in such a way that no persons are endangered or machines and other material goods are damaged in the event of malfunction or total failure of the system.
- Take additional precautions for safety and damage prevention in case of safety-related applications.

1.5 Proper Environment

- Protection class: IP30
- Ambient temperature: 0 ... +50 °C (+32 ... +122 °F)
- Storage temperature: -20 ... +75 °C (-4 ... +167 °F)
- Humidity: 10 ... 95 %, non-condensing

2. Technical Data

2.1 Functional Principle

The thermoIMAGER TIM NetPCQ is a miniaturized industry PC which expands the TIM series to a stand-alone solution or which works as a USB to Ethernet converter. This mode enables larger possible distances between process (IR camera) and process control (PC).

The thermoIMAGER NetPCQ includes a Windows 10 operating system that allows the user to install additional software. The housing of the thermoIMAGER NetPC is made of anodized aluminum.

2.2 General Specifications

Model	NetPC
Storage temperature	-20 ... +75 °C (-4 ... +167 °F)
Ambient temperature	0 ... +50 °C (+32 ... +122 °F)
Relative humidity	10 ... 95 %, non-condensing
Material (housing)	Anodized aluminum
Dimensions	117.5 mm x 165 mm x 64.5 mm (L x B x H)
Weight	1000 g
Vibration	IEC 68-2-6: 3 G, 11 - 200 Hz, any axis
Shock	IEC 68-2-27: 50 G, 11 ms, any axis
Operating system	Windows 10

2.3 Electrical Specifications

Model	NetPCQ
Power supply	12 ... 24 VDC
Power consumption	10 W (+additional 2.5 W for IR camera)
Cooling	passive
Processor	Intel Atom J1900 Quad Core CPU, 2 GHz
Hard disc	64 GB SSD
RAM	2 GB (DDR2, 533 MHz)
Ports	3 x USB 2.0
	1 x USB 3.0
	2 x RS232
	VGA
	Ethernet (Gigabit Ethernet)
Additional functions	Status LED

3. Delivery

3.1 Unpacking, Included in Delivery

1 TIM NetPCQ inclusive SSD (64 GB)

1 USB Recovery stick including operating manual

- ➡ Carefully remove the components of the measuring system from the packaging and ensure that the goods are forwarded in such a way that no damage can occur.
- ➡ Check the delivery for completeness and shipping damage immediately after unpacking.
- ➡ If there is damage or parts are missing, immediately contact the manufacturer or supplier.

3.2 Storage

- Storage temperature: -20 ... +75 °C (-4 ... +167 °F)
- Humidity: 10 ... 95 %, non-condensing

4. Mounting and Installation

The thermoIMAGER TIM NetPCQ can be mounted easily on a DIN rail (TS35) according EN50022 using the rail mount adapter on the backside of the box.

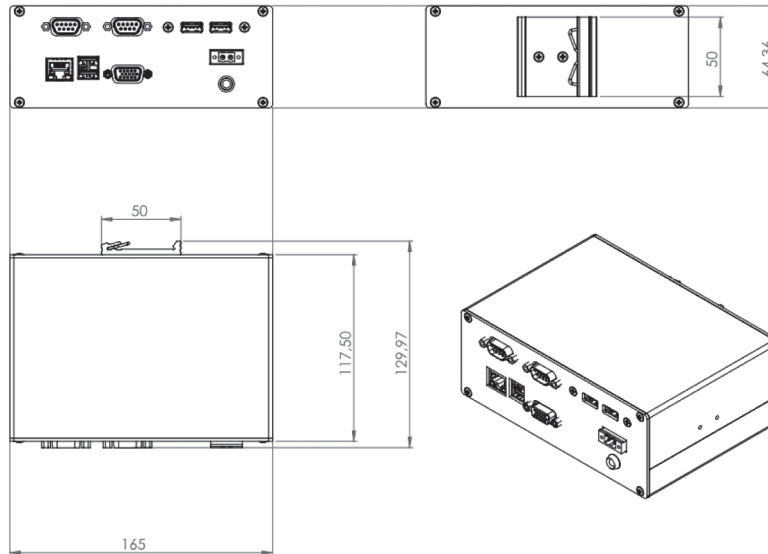
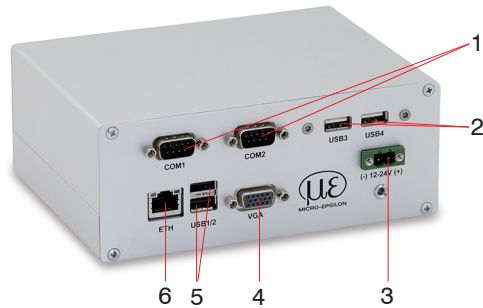

Fig. 1 Dimensional drawing thermoIMAGER TIM NetPCQ, dimensions in mm, not to scale

5. Control Elements and Connections



- 1 RS 232 Interface connections (two)
- 2 USB 2.0 connections (two)
- 3 DC power supply with power LED
- 4 VGA connection
- 5 1 x USB 3.0 and 1 x USB 2.0 connections
- 6 Ethernet connection

6. Operation

6.1 Operation Modes

The thermoIMAGER NetPCQ can be used in three different operation modes:

1. Converter USB – Ethernet with direct connection to a PC (point-to-point connection)
2. Converter USB – Ethernet with connection of a PC via a network or via the internet
3. Stand-alone operation with an IR camera

For powering the thermoIMAGER NetPCQ you can use any suitable industrial power supply with a voltage output between 12 VDC and 24 VDC, [see 2.3](#).

6.2 Remote Access to the thermoIMAGER TIM NetPCQ

For settings on the thermoIMAGER TIM NetPCQ you can connect a keyboard and a mouse to the available USB sockets as well as a monitor to the VGA socket, [see 6.8](#).

Another very simple option is remote control software, for example Remote Desktop (RDP) from Windows or Ultra VNC with NetBox Utility, which is already included on the TIM Connect software CD provided with thermoIMAGER TIM.

After installation you can have access to the thermoIMAGER TIM NetPCQ either from a PC directly connected over an Ethernet cable or from a PC which is located anywhere and connected to the same network. Also remote connection via the internet is possible.

➡ To install NetBox Utility on your PC, please start `install.bat` in the `/NetBox Utility` directory on the thermoIMAGER TIM Connect USB flash drive.

In addition to the utility software, the UltraVNC viewer will also be installed.

This program is available `Start/Programs/NetBox-UltraVNC`.

➡ Before starting the NetBox Utility on your PC, please follow the instructions for specifying a fixed IP address, [see 6.6](#).

➡ Next, please start the NetBox Utility program:

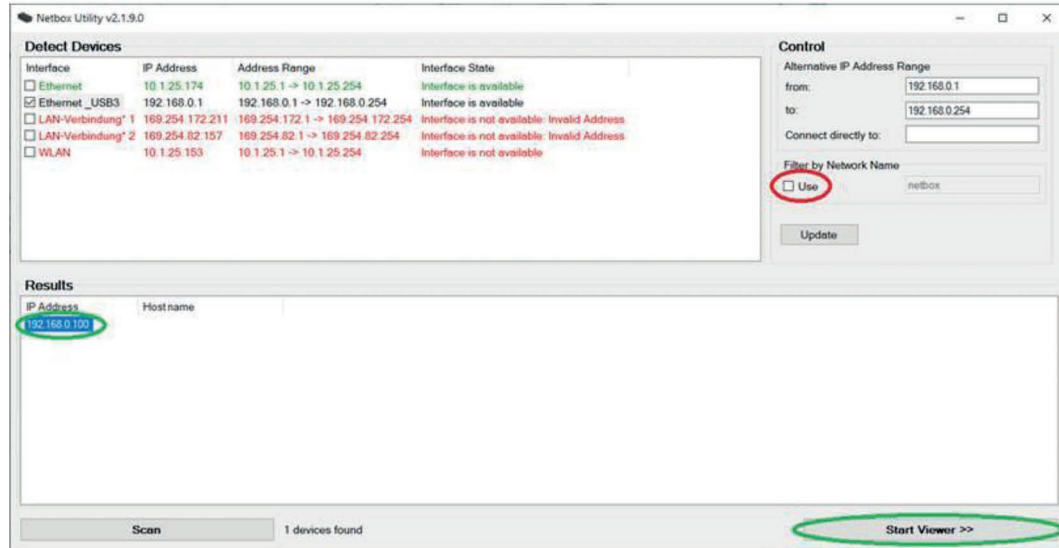

Fig. 2 View: Netbox Utility program start screen

➡ Select the desired network adapter.

➡ Remove the check mark from Filter by Network Name and click the Scan button.

The utility program now searches for NetPCQs that are in the network or are directly connected to your PC.

The devices found are shown in the Results window.

➡ Mark the desired address in the Results window and click the Start Viewer >> button.

You should now see the thermoIMAGER TIM NetPCQ screen.



Fig. 3 View: thermoIMAGER TIM NetPCQ start screen

6.3 Applications and Start Options

On the Desktop of the thermoIMAGER TIM NetPCQ you will find the following short cuts:

- TIM Connect
- Netbox Control Center



Fig. 4 Netbox Control Center shortcut

The Netbox Control Center allows for easy configuration of the NetPCQ.

6.3.1 NetBox Control Center

6.3.1.1 Select Tab

The **Select** tab lets you select programs that start automatically after powering on the NetPCQ.

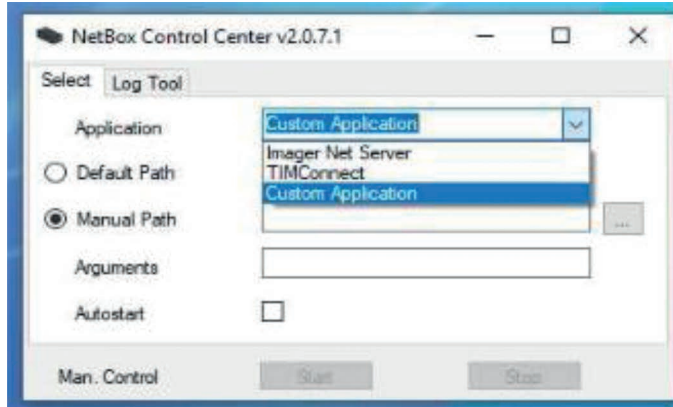

Fig. 5 Netbox Control Center - Select selection

Under **Application**, you can select **TIM Connect**, **Imager Net Server** or **Custom Application**.

Application	NetPC operating mode
TIM Connect	Stand alone operation
Imager Net Server	Converter operation USB-Ethernet
Custom Application	Using the NetPCQ with another software

The start options set in the Control Center are automatically saved on the NetPCQ and are also available after restarting.

Under **Arguments**, you can specify command line parameters (e.g., a special layout with which the **TIM Connect Software** starts automatically).

Arguments

/Path="D:\Imager" /Layout=NetBox

Autostart



Man. Control

Start

Stop

➡ Enable **Autostart** to have the selected application start automatically after the NetPCQ is started.

If for some reason the application no longer works properly (e.g., if the software has crashed), the Netbox Control Center automatically restarts it, if **Autostart** has been set (software watchdog).

6.3.1.2 Log Tool Tab

The Log Tool tab provides the following information:

Application	NetPC operating mode
Software Restarts	Number of software restarts performed
Reason for last hardware restart	Reason for the most recent restart of the NetPCQ
Software is not responding for	Timer, which starts when the software does not respond and triggers a restart of the selected application.
Actual runtime	Current runtime of the software
Previous runtime	Previous runtime of the software
Device Frequency	Camera image frequency
Process Frequency	Displayed image frequency
Net Transfer Frequency	Image frequency transferred via the network (for Imager Net Server)

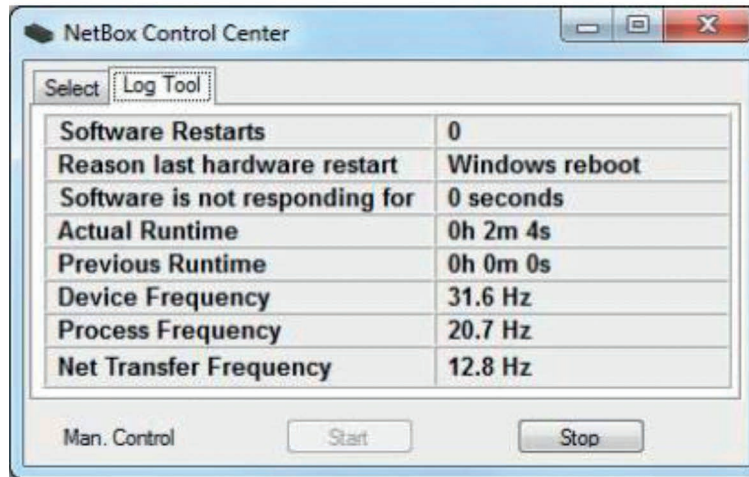

Fig. 6 Netbox Control Center - Log Tool selection

If an thermoIMAGER TIM is connected to the thermoIMAGER TIM NetPCQ, you should see two active applications: Log Tool and Imager Net Server, see Fig. 7, similarly Log Tool and TIM Connect, see Fig. 8.

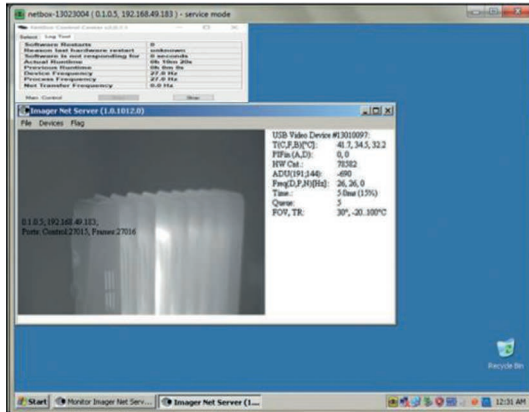

Fig. 7 View NetPCQ - Log Tool and Imager Net Server

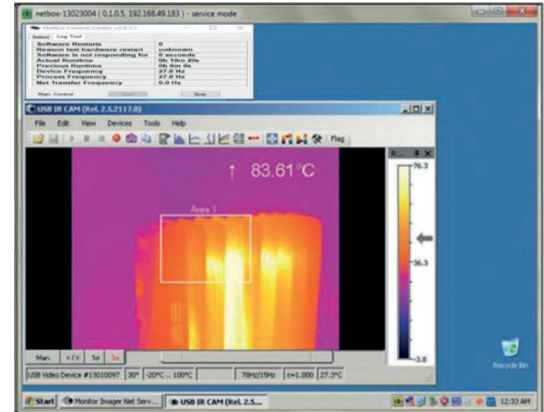

Fig. 8 View NetPCQ - Log Tool and TIM Connect

6.3.1.3 Imager Net Server



Imager Net Server, see Fig. 7			
Menu	File	Exit of the program	
	Devices	Shows the connected thermoIMAGERS TIM	
	Flag	Manual operation of the camera flag	
USB video device	Serial number of the connected imager device		
T (C, F, B)	Device temperatures (*C)		C: FPA-Chip
			F: Flag temperature
			B: Housing temperature
PIFin (A, D)	Status of the PIF input		A: Analog IN (AI)
			D: Digital IN (DI)
HW Cnt.	Hardware-Counter (frame counter)		
ADU (192, 144)	ADU value of the center TIMxel (e.g. 192, 144 at TIM4xx)		
Freq (D, P, N)	Frequency (Hz):		D: Device/ P: Processing/ N: Network
Time	Time per single frame		
Queue	Number of frames in network queue		
FOV, TR	Field of view (horizontal) of the imager lens, temperature range		

Fig. 9 Information in the Imager Net Server - application window

6.4 File Transfer between thermoIMAGER TIM NetPCQ and PC

- ➡ To exchange files between the thermoIMAGER TIM NetPCQ and a directly connected or in the network located PC please move the cursor to the title bar of the UltraVNC Viewer window and press the right mouse button.
- ➡ Start File Transfer.
- ➡ Alternatively you can also press the following button in the tool bar: 

In the following explorer window, see Fig. 10, you see on the left side your local PC (LOCAL MACHINE) and on the right side the thermoIMAGER TIM NetPCQ (REMOTE MACHINE).

- ➡ Now you can copy files between both computers via the network link by marking them and pressing Send or Receive.

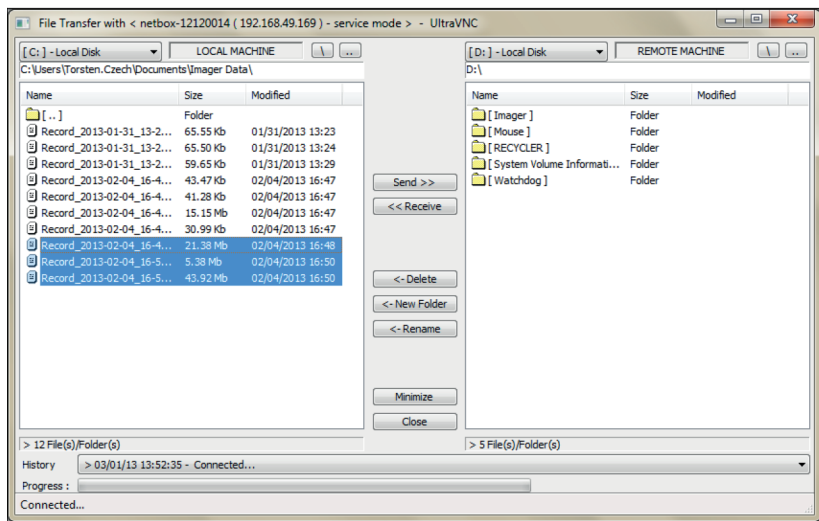

Fig. 10 File transfer view

6.5 Direct Ethernet Communication

- Please connect the thermoIMAGER TIM with the supplied USB connection cable with the thermoIMAGER TIM NetPCQ.
- Please connect your PC with an Ethernet cable with the thermoIMAGER NetPCQ.
- Now connect the power supply cable to the thermoIMAGER NetPCQ and to the mains supply.

The thermoIMAGER NetPCQ will start to boot the system and should be ready to use after 2 - 3 minutes.

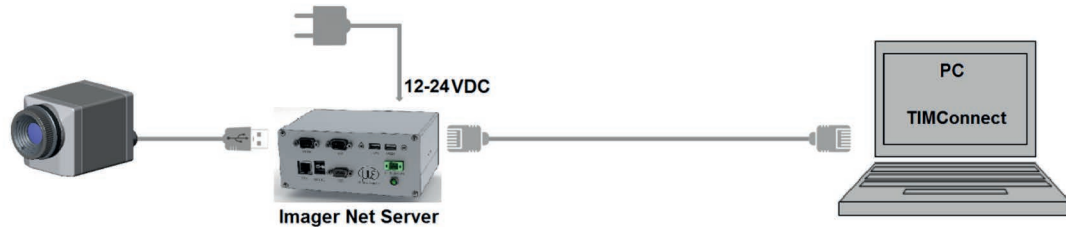

Fig. 11 Ethernet direct connection (point-to-point connection)/ thermoIMAGER TIM NetPCQ powered via power supply

- i** The used Ethernet cables should be at least category 5 cables (Cat-5 according ISO/IEC 11801).

6.6 Connection to the thermoIMAGER TIM NetPC

The communication with the TIM NetPCQ is done via the TCP/ IP protocol (Transmission Control Protocol/ Internet Protocol). The TIM NetPCQ can get its IP address (Internet Protocol address) either from a DHCP server or it can work with a fixed IP address.

➡ First switch on the thermoIMAGER NetPCQ, [see 6](#).

On a direct connection to a PC both, the thermoIMAGER TIM NetPCQ as well as the PC must use a fixed IP address because no DHCP server is available here. The thermoIMAGER TIM NetPCQ is using in this case the IP address 192.168.0.100.

On your PC you have to do the following settings once (depending on the operating system the procedure can differ from the here shown – the following description refers to a Windows 10 system).

➡ 1. Go to `System controls > Network > Internet` and open `Network and Sharing Center`.

➡ 2. If you have an existing connection to a network (company network e.g.) you should see the following information:

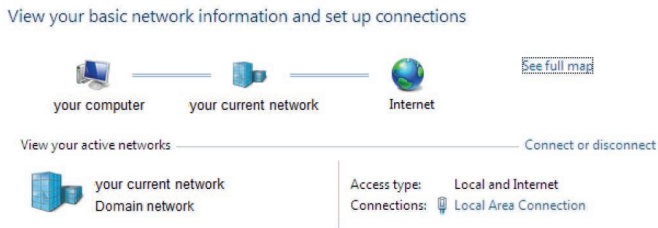

Fig. 12 Network center

➡ If your PC is not connected to any network, please go to `Change adapter settings` after you opened the `Network and Sharing Center`. Now go to `Local Area Connection` and right mouse button: `Properties`, continue at item 4.

➡ 3. Go to `Local Area Connection - a status view` according, [see Fig. 13](#), will be shown. Then go to `Properties`.

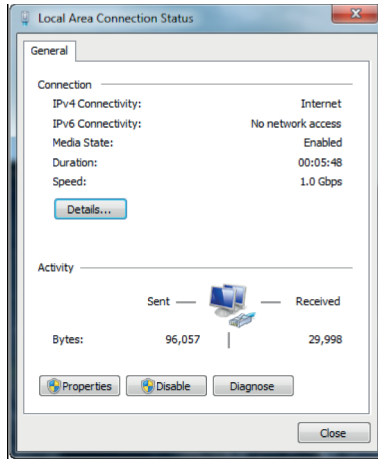

Fig. 13 Local Area Connection Status

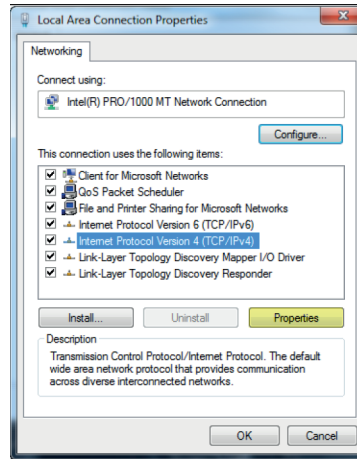

Fig. 14 Local Area Connection Properties

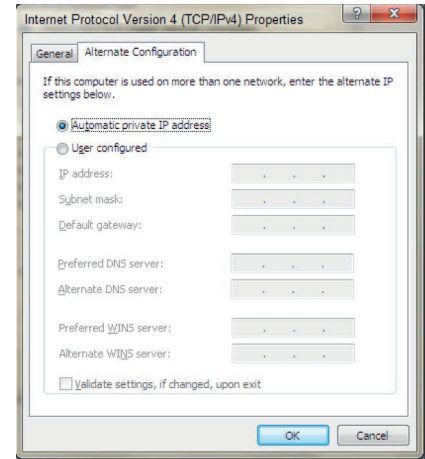

Fig. 15 Internet Protocol Version 4 (TCP/IPv4) Properties

- ➡ 4. In the Local Area Connection Properties window, see Fig. 14, mark Internet Protocol Version 4 (TCP/IPv4) and go again to Properties.
- ➡ 5. Please open now in Internet Protocol Version 4 (TCP/IPv4) Properties window, see Fig. 15, the register Alternate Configuration and activate the checkbox User configured.
- ➡ 6. Now enter a user-defined IP address for your PC. Note that the network portion of the address must be identical to the network portion of the IP address of the thermoIMAGER TIM NetPCQ, that is, it must be 192.168.0. However, the IP address of the device portion must be different from the thermoIMAGER TIM NetPCQ address (IP address 192.168.0.100); for example, use IP address 192.168.0.1, see Fig. 16.

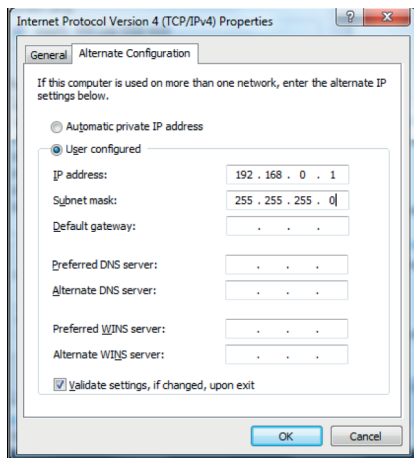

Fig. 16 Internet Protocol Version 4 (TCP/IPv4) - User configured IP address

After you have made these settings and connected your PC with the thermoIMAGER TIM NetPCQ using an Ethernet cable your PC will establish a point-to-point connection. This procedure can take several minutes.

In the Network and Sharing Center your network will now be shown up as a non-identified network.

- ➔ Please start now the thermoIMAGER TIM Connect on your PC and open the menu item `Tools/ Extended/ Remote devices...`
- ➔ In the window which is appearing, see Fig. 17, you should set a hook on `Enable` and enter the IP address of thermoIMAGER TIM NetPCQ (192.168.0.100) at IP address of current remote device.
- ➔ Press `OK`.

The software will establish a connection to the remote device thermoIMAGER NetPCQ automatically.

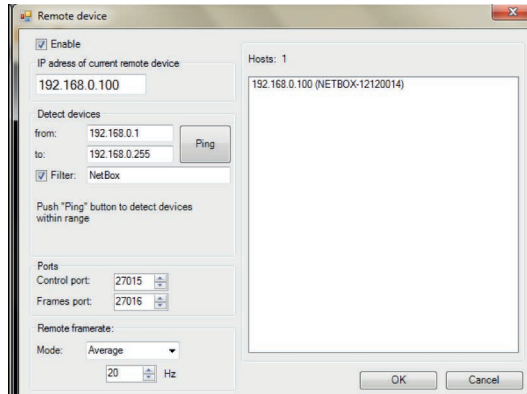

Fig. 17 Search for network devices in TIM Connect

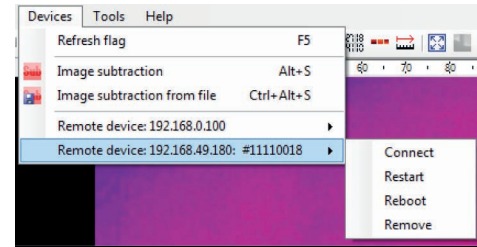

Fig. 18 Device selection in TIM Connect

Under Remote framerate, see Fig. 17, you can enter the desired frame rate which should be transmitted via the network.

Under the menu item Devices, see Fig. 18, the thermoIMAGER TIM which is connected to the thermoIMAGER NetPCQ shows up now. The following functions can be selected here:

- Connect Manual connection with the remote device
- Restart Restart of the Imager Net Server application on the thermoIMAGER TIM NetPCQ
- Reboot Reboot of the thermoIMAGER TIM NetPCQ
- Remove Remove of the device entry in this menu

If the used thermoIMAGER TIM is connected for the first time to the thermoIMAGER TIM NetPCQ the following message appears:

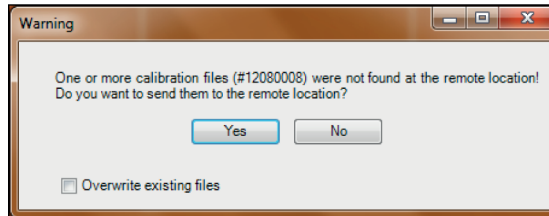

Fig. 19 Warning view

➡ Please confirm with **Yes**.

The calibration files will be transferred automatically from your PC to the thermoIMAGER TIM NetPCQ and stored there. Now you should see the live TIM picture from the thermoIMAGER TIM on your PC.

Alternatively you can copy the calibration data also manually via an USB stick into the thermoIMAGER TIM NetPCQ folder `D:\Imager\Cali`.

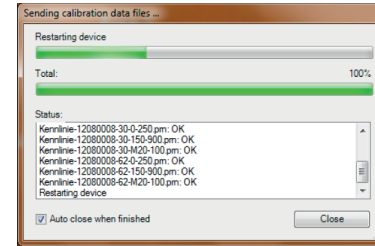

Fig. 20 Sending calibration data files

6.7 Ethernet Network Communication

- ▶ Please connect your thermoIMAGER TIM with the supplied USB connection cable with the thermoIMAGER TIM NetPCQ.
- ▶ Please connect the Ethernet connection of the thermoIMAGER TIM NetPCQ with a network or internet (via a router e.g.).
- ▶ Now connect the power supply to the thermoIMAGER TIM NetPCQ and to the mains. The thermoIMAGER TIM NetPCQ will start to boot the system and should be ready to use after 2 - 3 minutes.

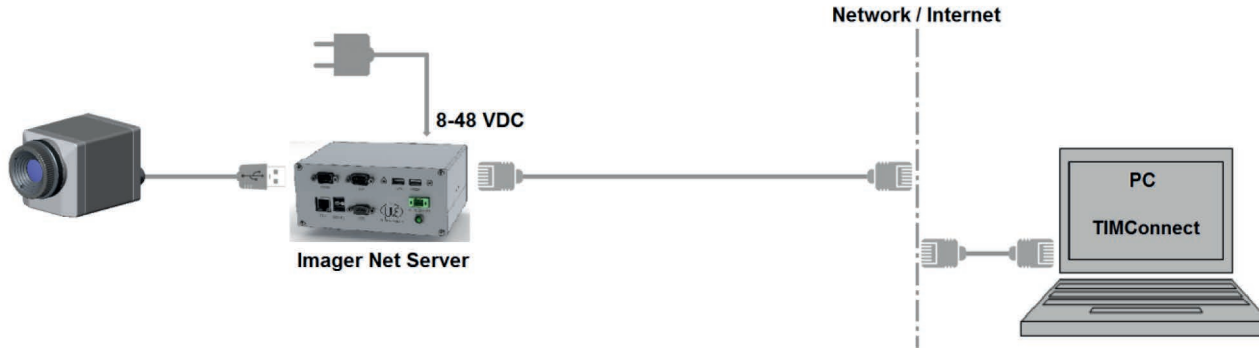

Fig. 21 Ethernet network connection / TIM NetPCQ powered via power supply

If the TIM NetPCQ is used in a network it gets its IP address from a DHCP server. In order to find the thermoIMAGER TIM NetPCQ in the thermoIMAGER TIM Connect of your local PC the address range of the local network must be known.

- ▶ Thereto please open the Network and Sharing Center on your local PC, go to Local Area connection, see Fig. 22 and open Details, see Fig. 23.

The Window Network Connection Details, see Fig. 24, shows now your own IPv4 address.

- ▶ Please start now the thermoIMAGER TIMConnect on your local PC and open the menu Tools > Extended > Remote devices
- ▶ In the window which opens, see Fig. 25, set a hook on Enable and enter the address range of your local network under Detect devices.

The fourth block should have the range 0 to 255.

➡ If you now press Ping, see Fig. 25, all computers inside the selected address range will be shown.



Fig. 22 Network center view: Local Area Connection

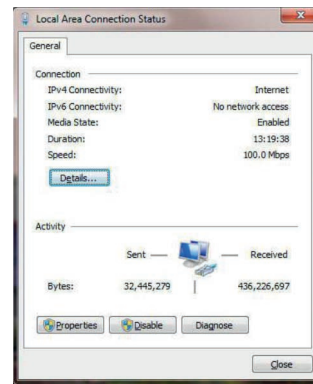

Fig. 23 Local Area Connection Status view

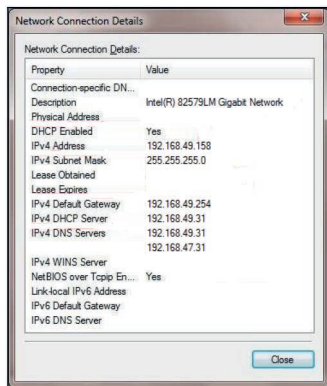

Fig. 24 Network Connection Details view

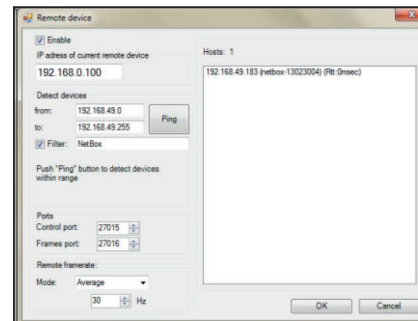

Fig. 25 Remote device view

Under `Remote framerate`, see Fig. 25, you can enter the desired frame rate which should be transmitted via the network.

Now only computers with NetPCQ in their name will be shown.

Under `Hosts`, see Fig. 25, you should see now your thermoIMAGER NetPCQ.

➡ Please mark this and press OK.

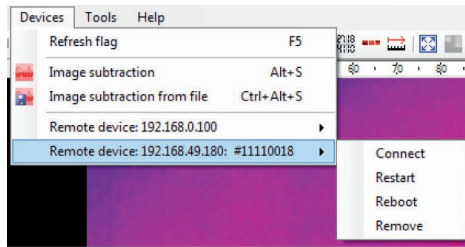

Fig. 26 Device selection in TIM Connect

Under the menu item `Devices`, see Fig. 26, the thermoIMAGER TIM which is connected to the thermoIMAGER NetPCQ shows up now.

The following functions can be selected here:

- Connect Manual connection with the remote device
- Restart Restart of the Imager Net Server application on the thermoIMAGER TIM NetPCQ
- Reboot Reboot of the thermoIMAGER TIM NetPCQ
- Remove Remove of the device entry in this menu

If the used thermoIMAGER TIM is connected for the first time to the thermoIMAGER NetPCQ the following message appears:

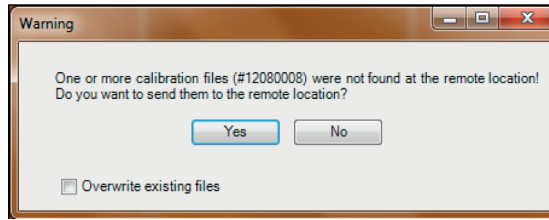

Fig. 27 Warning view

➡ Please confirm with Yes.

The calibration files will be transferred automatically from your PC to the thermoIMAGER TIM NetPCQ and stored there. Now you should see the live TIM picture from the thermoIMAGER TIM on your PC.

Alternatively you can copy the calibration data also manually via an USB stick into the thermoIMAGER TIM NetPCQ folder D:\Imager\Cali.

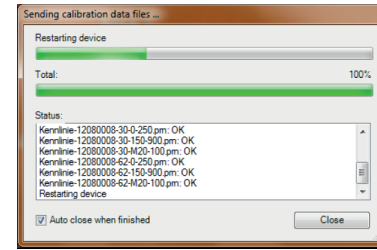

Fig. 28 Sending calibration data files

6.8 Stand-alone Operation

As a stand-alone PC the thermoIMAGER NetPCQ can expand a IR camera to a separate system. For this operation mode you should connect a VGA display and a USB keyboard to the thermoIMAGER NetPCQ. In addition the system can also be controlled via a remote access over an Ethernet connection, [see 6.2](#).

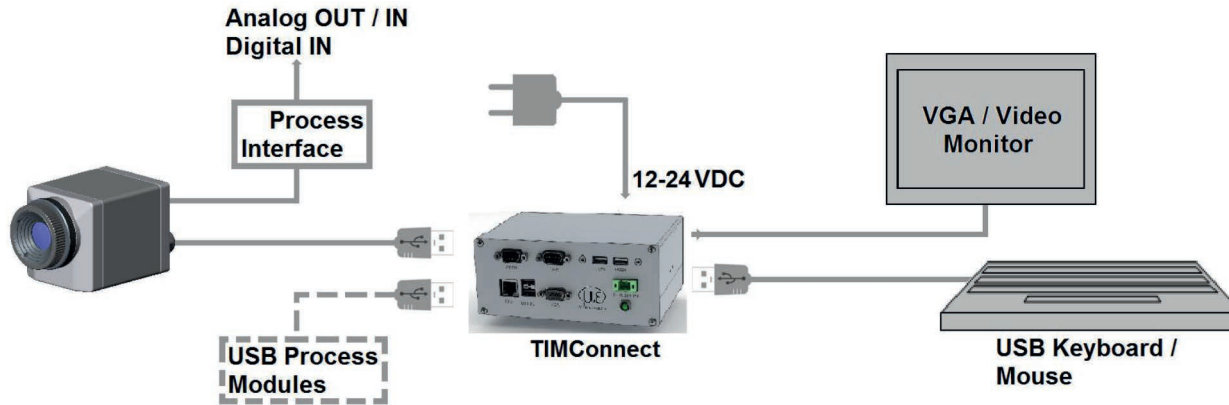

Fig. 29 Stand-Alone operation/ thermoIMAGER TIM NetPCQ powered via power supply

After booting the thermoIMAGER NetPCQ the first time you will see the Imager Net Server application.

- ▶ Please close the monitor program and change it to thermoIMAGER TIM Connect in the configuration dialog (Netbox Control Center), [see 6.3](#).

6.9 Write Protection Filter

In Windows 10, you can assign a write protection filter to individual drives.

The operating system and TIM Connect software are saved on drive C. Below are steps you can perform to assign a write protection filter to that drive.

By default, the Unified Write Filter (UWF) is disabled. To enable UWF in Windows 10, proceed as follows:

➤ Open System control > Programs and Features > Turn Windows-Features on or off.

1. To do so, you need administrator rights.

➤ Enable Unified Write Filter under Device Lockdown, see Fig. 30.

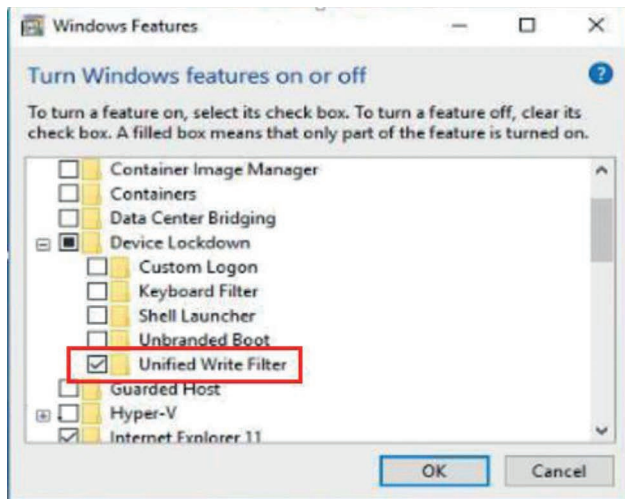

Fig. 30 View: System control - Windows Features - Device Lockdown

Der UWF filter is operated using command lines.

Note the following steps:

Step 1:

➡ Open the `Command Prompt` using the `CMD` command and run it as an administrator.

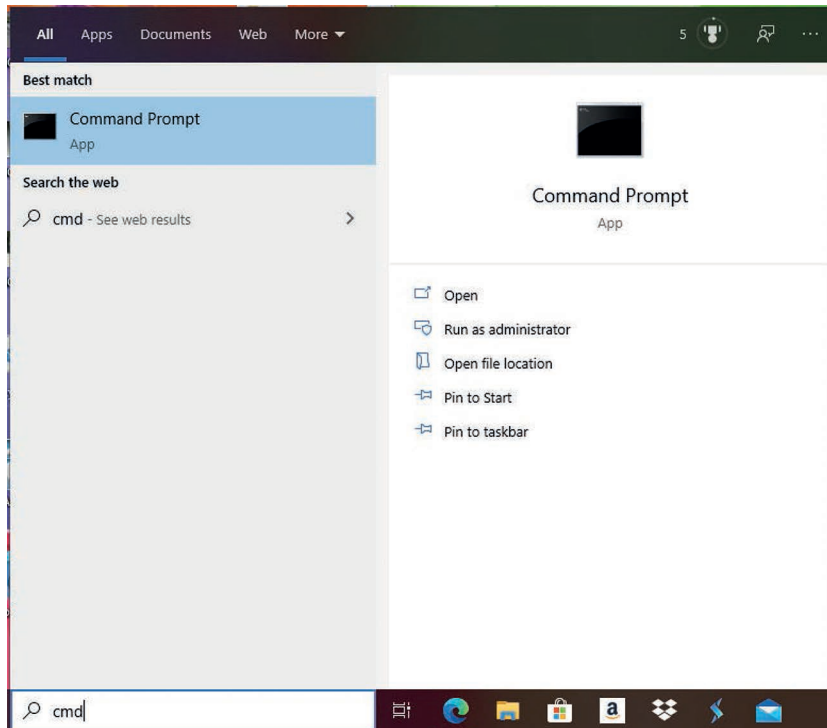
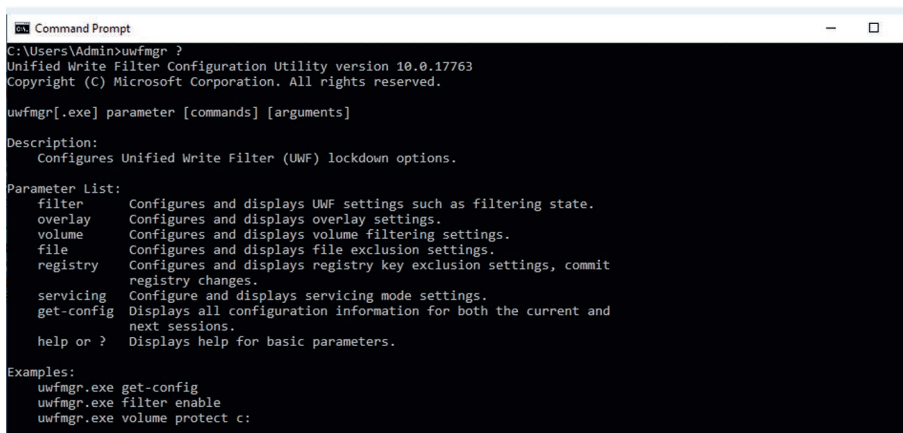

Fig. 31 View: Command Prompt - Run as administrator

Step 2: All commands for the UWF filter start with `uwfmgr`.

Using the `uwfmgr ?` command, you can display all available commands for the filter.



```
Command Prompt
C:\Users\Admin>uwfmgr ?
Unified Write Filter Configuration Utility version 10.0.17763
Copyright (C) Microsoft Corporation. All rights reserved.

uwfmgr[.exe] parameter [commands] [arguments]

Description:
  Configures Unified Write Filter (UWF) lockdown options.

Parameter List:
  filter      Configures and displays UWF settings such as filtering state.
  overlay     Configures and displays overlay settings.
  volume      Configures and displays volume filtering settings.
  file        Configures and displays file exclusion settings.
  registry    Configures and displays registry key exclusion settings, commit
              registry changes.
  servicing   Configure and displays servicing mode settings.
  get-config  Displays all configuration information for both the current and
              next sessions.
  help or ?   Displays help for basic parameters.

Examples:
  uwfmgr.exe get-config
  uwfmgr.exe filter enable
  uwfmgr.exe volume protect c:
```

Fig. 32 Command overview uwfmgr

The `uwfmgr get-config` command lets you retrieve the current status of the filter.

If the UWFM filter is turned off, the following view is displayed:

```
Command Prompt

REGISTRY EXCLUSIONS
Not available

Next Session Settings

FILTER SETTINGS
  Filter state: OFF
  Pending commit: N/A

SERVICING SETTINGS
  Servicing State: OFF

OVERLAY SETTINGS
  Type: RAM
  Maximum size: 1024 MB
  Warning Threshold: Not available
  Critical Threshold: Not available
  Freespace Passthrough: Not available
  Persistent: (null)
  Reset Mode: N/A

VOLUME SETTINGS
Volume fe9b6803-0000-0000-0000-702200000000 [C:]
  Volume state: Protected
  Volume ID: fe9b6803-0000-0000-0000-702200000000
```

Fig. 33 UWFM filter turned off

➔ To enable the filter, enter the `uwfmgr filter enable` command.

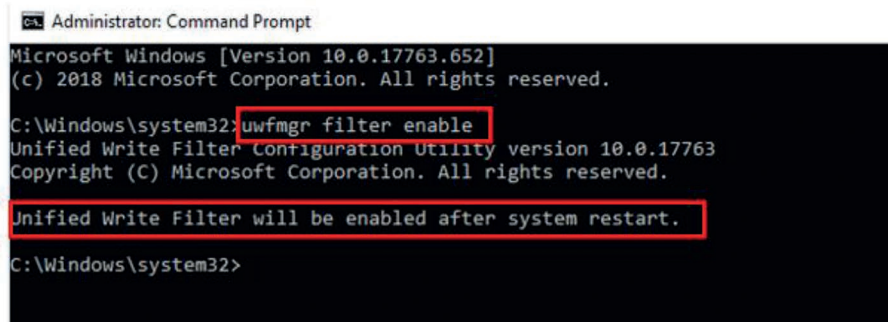

```
Administrator: Command Prompt
Microsoft Windows [Version 10.0.17763.652]
(c) 2018 Microsoft Corporation. All rights reserved.

C:\Windows\system32>uwfmgr filter enable
Unified Write Filter Configuration Utility version 10.0.17763
Copyright (C) Microsoft Corporation. All rights reserved.

Unified Write Filter will be enabled after system restart.

C:\Windows\system32>
```

Fig. 34 Command `uwfmgr filter enable`

To enable the write filter, you must restart the system!

To disable the filter again, use the `uwfmgr filter disable` command.

To now assign the write protection filter to hard drive C, use the `uwfmgr volume protect c` command.

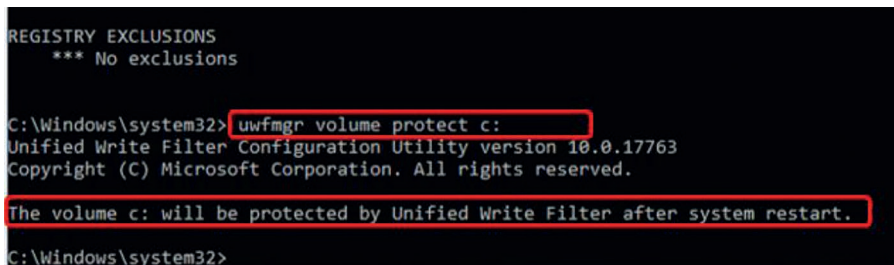

```
REGISTRY EXCLUSIONS
*** No exclusions

C:\Windows\system32>uwfmgr volume protect c:
Unified Write Filter Configuration Utility version 10.0.17763
Copyright (C) Microsoft Corporation. All rights reserved.

The volume c: will be protected by Unified Write Filter after system restart.

C:\Windows\system32>
```

To disable the protection of hard drive C again, enter the `uwfmgr volume unprotect c:` command.

6.10 System Recovery

If a recovery of the Windows operating system of the thermoIMAGER TIM NetPCQ is required, please use the included USB flash drive.

- 1 Follow the steps below and do not disconnect the power supply to the thermoIMAGER TIM NetPCQ during the recovery under any circumstances.

After recovery, the thermoIMAGER TIM NetPCQ is in default mode; that is, any data saved to the SSD are lost.

Step 1:

- Connect a VGA monitor and USB keyboard to the thermoIMAGER NetPCQ.
- Connect the USB recovery flash drive to a USB port and turn on the thermoIMAGER NetPCQ.
- Once you see the start screen below, see Fig. 35, press the DEL key.



Fig. 35 Start screen of system recovery

Step 2:

The following view is now displayed:

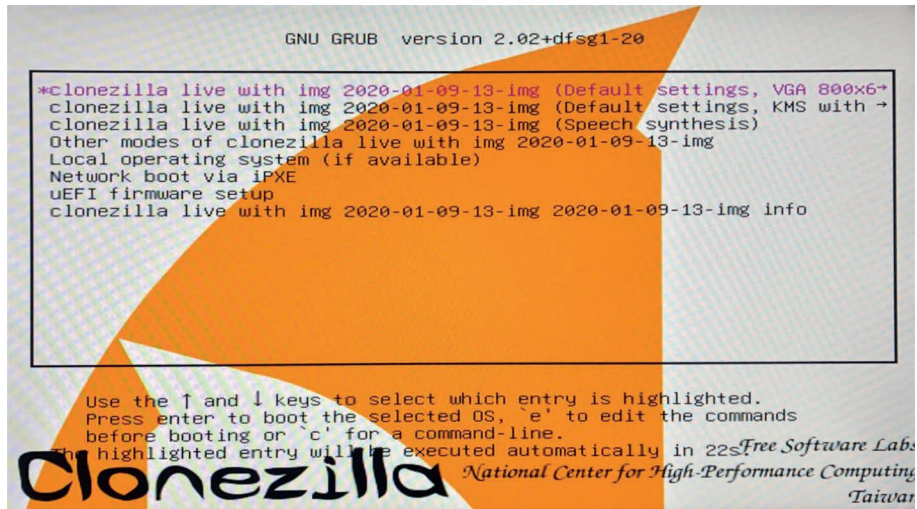

➡ Select Enter.

The warning below, asking whether you really want to recover the system, is displayed:

```

E-Mail  Brennen  Öffnen
Machine: To be filled by 0.E.M.
sda (64.0GB_SQF-SHMM2-64G-S9_SQF-SHMM2-64G-S9C_FF360755160801882262)
sda1 (550M_ntfs_System_Reser(In_SQF-SHMM2-64G-S9)_SQF-SHMM2-64G-S9C_FF360755160
01882262)
sda2 (20G_ntfs(In_SQF-SHMM2-64G-S9)_SQF-SHMM2-64G-S9C_FF360755160801882262)
sda3 (39.1G_ntfs_User_Data(In_SQF-SHMM2-64G-S9)_SQF-SHMM2-64G-S9C_FF36075516080
882262)
*****
Hollen Sie wirklich weitermachen? (y/n) y
OK, dann machen wir's!!
This program is not started by clonezilla server.
*****
Ich frage nochmal zur Sicherheit.
Im nächsten Schritt wird ein Image auf die Festplatte oder die Partitionen auf
iesem System wiederhergestellt: "/home/partimag/2020-01-09-13-img" -> "sda sda1
sda2 sda3"
Das Image wurde erzeugt am: 2020-0204-1802
WARNUNG!!! WARNUNG!!! WARNUNG!!!
WARNUNG. ALLE DATEN AUF DIESER FESTPLATTE/DIESEN PARTITION(EN) WERDEN ÜBERSCHRIBEN!
ALLE VORHANDENEN DATEN GEHEN VERLOREN!!
*****
Machine: To be filled by 0.E.M.
sda (64.0GB_SQF-SHMM2-64G-S9_SQF-SHMM2-64G-S9C_FF360755160801882262)
sda1 (550M_ntfs_System_Reser(In_SQF-SHMM2-64G-S9)_SQF-SHMM2-64G-S9C_FF360755160
01882262)
sda2 (20G_ntfs(In_SQF-SHMM2-64G-S9)_SQF-SHMM2-64G-S9C_FF360755160801882262)
sda3 (39.1G_ntfs_User_Data(In_SQF-SHMM2-64G-S9)_SQF-SHMM2-64G-S9C_FF36075516080
882262)
*****
Hollen Sie wirklich weitermachen? (y/n) -

```

Fig. 36 Query recovery

➡ Confirm with *y*.

Step 3:

- After shutting down, briefly disconnect the power supply.
- Now reconnect the power supply and restart the computer .

You will see the following screen:

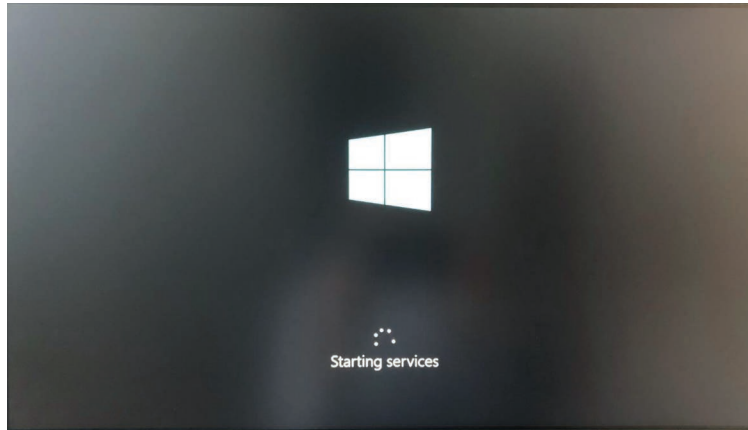

➔ Select your region and confirm with **yes**.

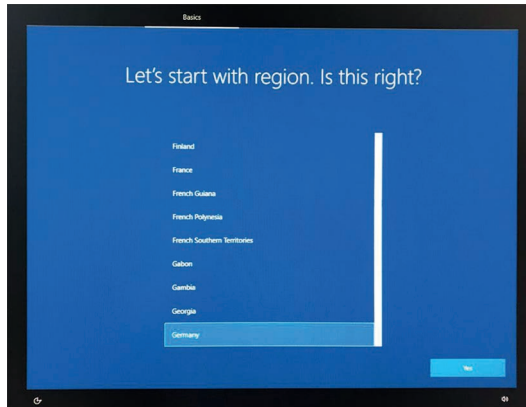

➔ Now select your keyboard layout and confirm with **yes**.

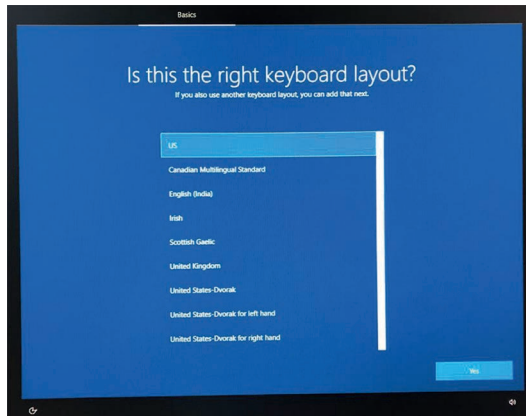

i Please note that the region and keyboard layout selections cannot be changed later.

Next, the Windows 10 licensing terms are displayed.

➡ Please confirm these with **Accept**.



Step 4:

After the final restart, you now see the Windows desktop.



7. Instructions for Operation

7.1 Cleaning

The housing of the thermoIMAGER NetPCQ can be cleaned with a soft, humid tissue moistened with water or a water based cleaner.

NOTICE

Never use cleaning compounds which contain solvents. Take care that no moisture infiltrates into the housing.

> Destruction of the Mini-PC

8. Liability for Material Defects

All components of the device have been checked and tested for functionality at the factory. However, if defects occur despite our careful quality control, MICRO-EPSILON or your dealer must be notified immediately.

The liability for material defects is 12 months from delivery. Within this period, defective parts, except for wearing parts, will be repaired or replaced free of charge, if the device is returned to MICRO-EPSILON with shipping costs prepaid. Any damage that is caused by improper handling, the use of force or by repairs or modifications by third parties is not covered by the liability for material defects. Repairs are carried out exclusively by MICRO-EPSILON.

Further claims can not be made. Claims arising from the purchase contract remain unaffected. In particular, MICRO-EPSILON shall not be liable for any consequential, special, indirect or incidental damage. In the interest of further development, MICRO-EPSILON reserves the right to make design changes without notification.

For translations into other languages, the German version shall prevail.

9. Service, Repair

In the event of a defect on the Mini-PC or the USB stick (USB recovery stick) please send us the affected parts for repair or exchange.

In the case of faults the cause of which is not clearly identified, please send the entire measuring system to:

For customers in USA apply:

Send the affected parts or the entire measuring system back to:

For customers in Canada or South America applies:
Please contact your local distributor.

10. Decommissioning, Disposal

➡ Remove the cables from the Mini-PC.

Incorrect disposal may cause harm to the environment.

➡ Dispose of the device, its components and accessories, as well as the packaging materials in compliance with the applicable country-specific waste treatment and disposal regulations of the region of use.

MICRO-EPSILON MESSTECHNIK
GmbH & Co. KG
Koenigbacher Str. 15
94496 Ortenburg / Germany
Tel. +49 (0) 8542/ 168-0
Fax +49 (0) 8542 / 168-90
info@micro-epsilon.com
www.micro-epsilon.com

MICRO-EPSILON USA
8120 Brownleigh Dr.
Raleigh, NC 27617 /USA
Tel. +1 919 / 787-9707
Fax +1 919 / 787-9706
me-usa@micro-epsilon.com
www.micro-epsilon.com



Instruction Manual
thermoIMAGER TIM NetBox

Mini PC for TIM series

MICRO-EPSILON
MESSTECHNIK
GmbH & Co. KG
Königbacher Strasse 15

94496 Ortenburg / Germany

Tel. +49 (0) 8542 / 168-0
Fax +49 (0) 8542 / 168-90
e-mail info@micro-epsilon.de
www.micro-epsilon.com

Notes on CE Marking

The product accomplishes the requirements of the EMC Directive 2014/30/EU.

Read the manual carefully before the initial start-up. The producer reserves the right to change the herein described specifications in case of technical advance of the product. References to other chapters are marked as [► ...].

Liability for Material Defects

All components of the device have been checked and tested for perfect function in the factory. In the unlikely event that errors should occur despite our thorough quality control, this should be reported immediately to MICRO-EPSILON.

The warranty period lasts 12 months following the day of shipment. Defective parts, except wear parts, will be repaired or replaced free of charge within this period if you return the device free of cost to MICRO-EPSILON.

This warranty does not apply to damage resulting from abuse of the equipment and devices, from forceful handling or installation of the devices or from repair or modifications performed by third parties.

No other claims, except as warranted, are accepted. MICRO-EPSILON will specifically not be responsible for eventual consequential damage. The terms of the purchasing contract apply in full.

MICRO-EPSILON always strives to supply the customers with the finest and most advanced equipment. Development and refinement is therefore performed continuously and the right to design changes without prior notice is accordingly reserved. For translations in other languages, the data and statements in the German language operation manual are to be taken as authoritative.

Content

	Page		Page
Description	3	System Information	34
Unpacking, Included in Delivery	3	Watchdog	34
Maintenance	4	Startup	35
Cautions	4	System Time	36
Technical Data	5	System Recovery	37
General Specifications	5		
Electrical Specifications	5		
Installation	6		
Mounting	6		
Controls and Connections	7		
Protective Housing	8		
SD Card	10		
Mini-USB Socket	10		
Power Supply	10		
Operation	11		
Operation Modes	11		
Status LEDs	11		
Stand-Alone Operation	12		
Network Settings	14		
Remote Access for the TIM NetBox	19		
File Transfer between TIM NetBox and PC	22		
TIM NetBox Control Center	23		
Converter Mode USB – Ethernet	28		
Write Protection Filter	32		

Description

The TIM NetBox is a miniaturized PC which expands the TIM series to a stand-alone solution or which works as a USB to Ethernet converter. This mode generates larger possible distances between process (IR camera) and process control (PC).

The TIM NetBox includes a Windows 7 Professional operating system that allows the user to install additional software.

The housing of the TIM NetBox is made of anodized aluminum – the optional TIM NetBox protection housing supports the usage in industrial environments (IP 65/ NEMA-4 rating).

Unpacking, Included in Delivery

- TIM NetBox incl. micro SDHC card (32 GB)
- Power supply (100 - 240 VAC / 24 VDC)
- HDMI cable (Micro HDMI to HDMI/ 1.5 m)
- Ethernet cable, 1 m
- System recovery stick (USB/ 8 GB)
- Rail mount adapter
- Instruction manual



Maintenance

The housing of the TIM NetBox can be cleaned with a soft, humid tissue moistened with water or a water based cleaner.

PLEASE NOTE: Never use cleaning compounds which contain solvents. Take care that no moisture infiltrates into the housing.

Cautions

Take care that no foreign substances penetrate into the venting slots of the TIM NetBox. In case of problems or questions which may arise when you use the TIM NetBox, please contact our service department.

**Please use only the threads in the housing or the supplied rail mount adapter for mechanical installation of the TIM NetBox.
Avoid mechanical violence – this may destroy the system (expiry of warranty).**

Technical Data

General Specifications

Operating temperature	0 ... 50 °C (+32 ... +122)
Storage temperature	-20 ... 75 °C (-4 ... +167)
Relative humidity	10 ... 95 %, non-condensing
Material (housing)	Anodized aluminum
Dimensions	113 mm x 57 mm x 47 mm (L x W x H)
Weight	385 g
Vibration	IEC 680068-2-6 (sinus shaped) IEC 680068-2-64 (broadband noise)
Shock	IEC 680068-2-27 (25 g and 50 g)
Operating system	Windows 7 Professional

Electrical Specifications

Power supply	8 ... 48 VDC or Power over Ethernet (PoE/ 1000BASE-T)
Power consumption	7.5 W (+ additional 2.5 W for IR camera)
Cooling	active via two integrated fans
Board	COM Express mini embedded board
Processor	Intel® Atom™ E3845, Quad Core, 1.91 GHz
Hard disc	16 GB SSD
RAM	2 GB (DDR2, 533 MHz)
Ports	2x USB 2.0/ 1x USB 3.0/ 1x Mini-USB 2.0 Micro HDMI Ethernet (Gigabit Ethernet)
Extensions	Micro SDHC or SDXC card
Additional functions	4 x Status LEDs (L1 – L4)

Installation Mounting

The TIM NetBox can be mounted easily on a DIN rail (TS35) according EN50022 using the supplied rail mount adapter. For this purpose please screw the 4 screws (M4) into the designated holes on the upper side of the TIM NetBox housing. Now you can place the rail mount adapter on the housing and fix it with the 4 nuts. On the bottom side of the TIM NetBox housing you will find 4 holes M2,5 which also can be used for mounting.

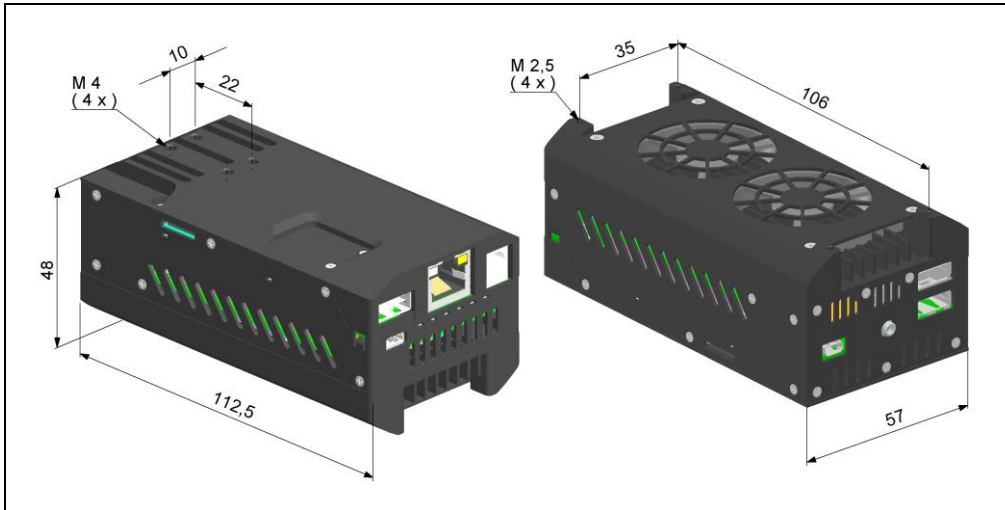

Dimensions TIM NetBox in mm, not to scale

Controls and Connections

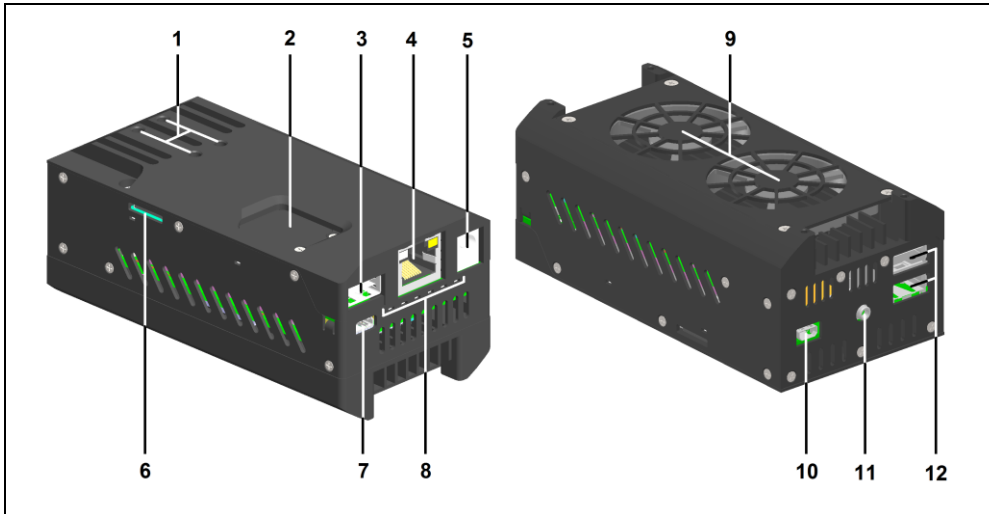

- 1 Mounting holes for rail mount adapter
- 2 CMOS battery compartment
- 3 USB 3.0 socket
- 4 Ethernet socket (GigE)
- 5 Power supply socket
- 6 Micro SDHC/ SDXC card slot
- 7 Mini-USB 2.0 socket
- 8 Status-LEDs (L1 – L4)

- 9 Cooling fans
- 10 Micro HDMI socket
- 11 Functional input (presently inactive)
- 12 2x USB 2.0 sockets

Protective Housing

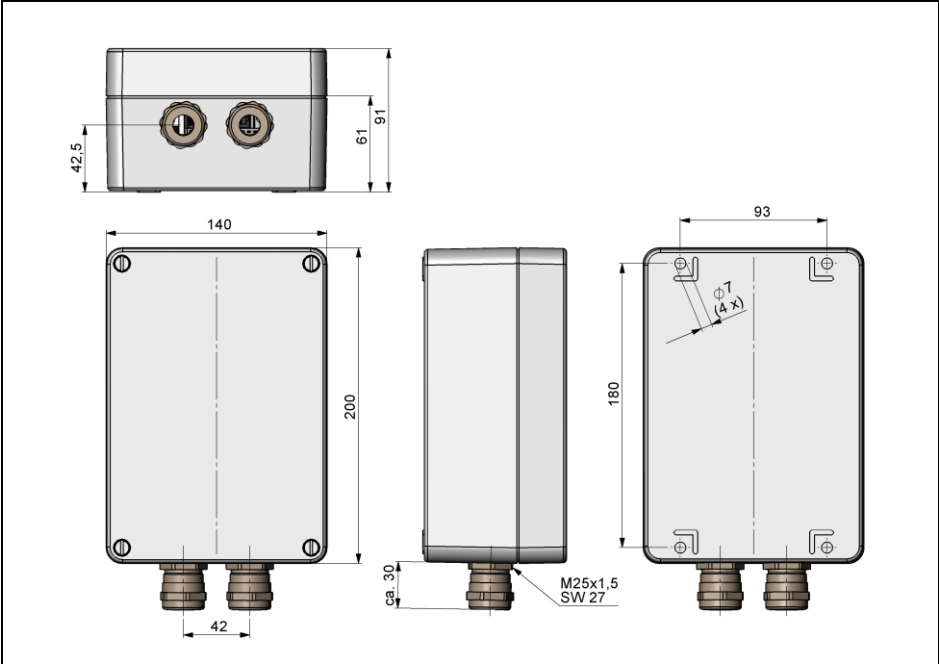

IP 65 Protective housing (Alu die-cast) (TM-NBPH-TIM), dimensions in mm, not to scale



Prospective housing with power supply (TM-NBPHPS-TIM)



IR camera inside CoolingJacket Advanced, connected to a TIM NetBox

(TM-NBPHPS-TIM)

SD Card

The TIM NetBox will be delivered with a 32 GB Micro SDHC card which is already installed on the unit. If required you can exchange this card.

The TIM NetBox is supporting Micro SDHC and Micro SDXC cards.

To remove the card please take a ball pen or similar and push onto the card from outside carefully. Please take care when you insert a card that it is placed correctly into the according guide slot.

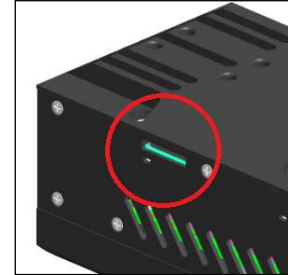

Mini-USB Socket

With the Mini-USB socket you can get a direct access to the IR camera from a separate PC without changing cables on the TIM NetBox.

For this purpose the camera needs to be connected to the USB 3.0 socket.

Power Supply

For powering the TIM NetBox you either can use the supplied power adapter or a suitable industrial power supply with a voltage output between 8 VDC and 48 VDC [**► Technical Data**].

Alternatively the TIM NetBox can also be powered via the Ethernet cable (PoE – Power over Ethernet).

For this purpose a PoE injector is needed (Part-No.: TM-POE-TIM)¹.

¹ For usage of the NetBox together with the high temperature Ethernet cables we recommend the following PoE components instead of TM-POE-TIM: Trendnet TPI-115GI or Netgear GS110TP

Operation

Operation Modes

The TIM NetBox can be used in three different operation modes:

1. Stand-alone operation with an IR camera
2. Converter USB – Ethernet with direct connection to a PC (point-to-point connection)
3. Converter USB – Ethernet with connection of a PC via a network or via the internet

Status LEDs

The TIM NetBox is equipped with 4 status LEDs (L1 - L4).

LED	Function	LED lights up if...
L1	Power	NetBox is powered via PoE or by power supply (via power connector)
L2	Net data	video frames are continuously transmitted through the network connection (flashing)
L3	USB data	the imager is connected to an USB port, calibration files are loaded, and raw data frames are continuously delivered by the imager (flashing)
L4	Application OK	the main application (PICconnect or Imager Net Server) is running
L5	not active	
L6	not active	

Stand-Alone Operation

As a stand-alone PC the TIM NetBox can expand an IR camera to an autonomous system. For this operation mode you should connect a monitor with a HDMI input and a USB keyboard to the TIM NetBox. If your monitor has only a DVI input please use a customary HDMI to DVI adapter. In addition the system can also be controlled via a remote access over an Ethernet connection. **[► Remote Access to the TIM NetBox]**

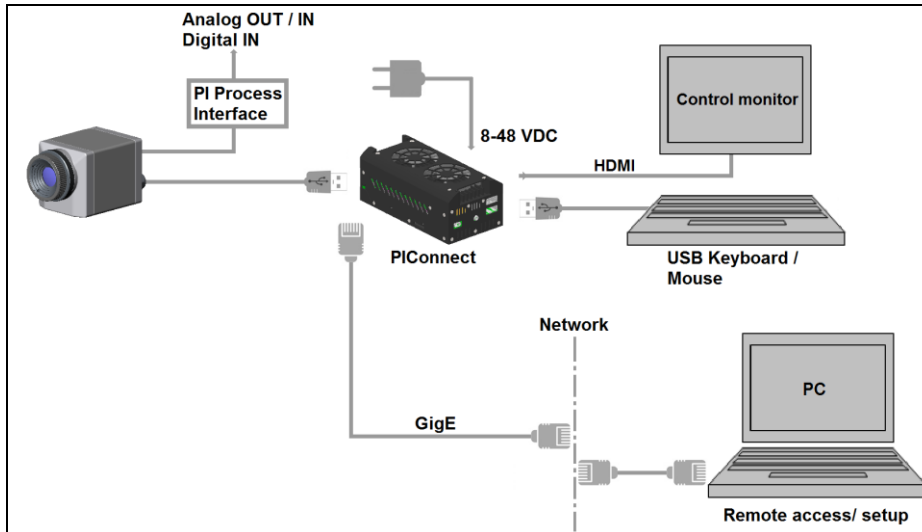

Stand-alone operation with remote monitoring via GigE network/ TIM NetBox powered via power supply

After booting the TIM NetBox the **PICconnect** software starts automatically. If a thermoIMAGER TIM is connected the first time to the TIM NetBox the software will ask you for the calibration files.

If you connect the TIM NetBox to the Internet using the Ethernet connection the calibration files will be downloaded automatically. Otherwise you can load the calibration files also manually via the menu Tools/ Extended/ Reimport calibration files (from an USB stick e.g.).

Network Settings

Please connect your imager with the supplied USB connection cable with the TIM NetBox. Please connect your PC with an Ethernet cable with the TIM NetBox. Now connect the power supply to the TIM NetBox and to the mains. The TIM NetBox will start to boot the system and should be ready to use after 1-2 minutes. You can check the status with the LEDs. At proper functioning now L1 should light up.

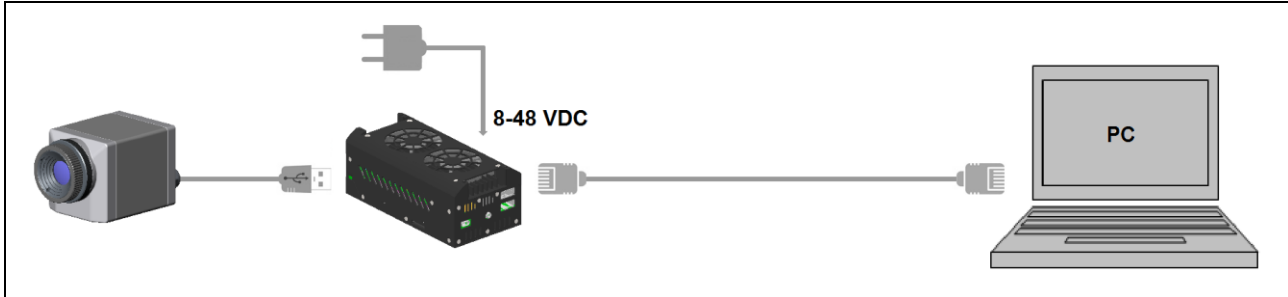

Ethernet direct connection (point-to-point connection)/ TIM NetBox powered via power supply

If you use a PoE injector the power supply for the TIM NetBox is not needed. In this case please connect the PoE injector as shown in the drawing below.

The used Ethernet cables should be at least category 5 cables (Cat-5 according ISO/IEC 11801).

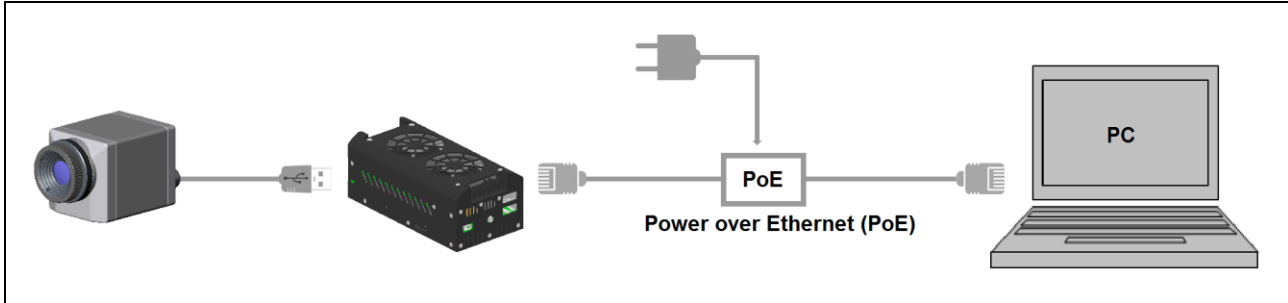

Ethernet direct connection (point-to-point connection)/ TIM NetBox powered via PoE injector

Connection to the TIM NetBox

The communication with the NetBox is done via the TCP/ IP protocol (Transmission **C**ontrol **P**rotocol/ Internet **P**rotocol). The TIM NetBox can get its IP address (Internet **P**rotocol address) either from a DHCP server or it can work with a fixed IP address.

On a direct connection to a PC both, the TIM NetBox as well as the PC must use a fixed IP address because no DHCP server¹⁾ is available here. The TIM NetBox is using in this case the IP address **192.168.0.100**. On your PC you have to do the following settings once (depending on the operating system the procedure can differ from the here shown – the following description refers to a Windows 7 system).

1) DHCP – Dynamic Host Configuration Protocol: allows the automatic integration of a computer into an existing network.

1. Go to **System controls**; open **Network and Sharing Center**.
2. If you have an existing connection to a network (company network e.g.) you should see the following information:

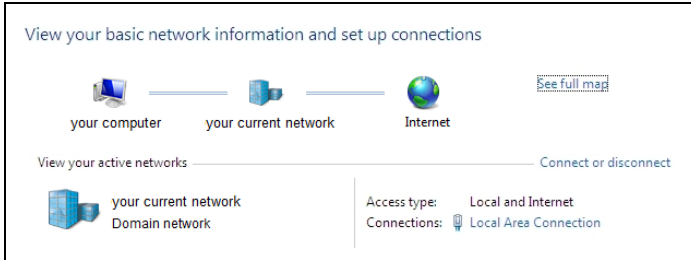

If your PC is not connected to any network, please go to **Change adapter settings** after you opened the **Network and Sharing Center**. Now go to **Local Area Connection**, right mouse button: **Properties**.
[continue at item 4]

3. Go to **Local Area Connection** – a status screen according [1] will be shown. Then go to **Properties**.
4. In the following window [2] mark **Internet protocol Version 4 (TCP/IPv4)** and go again to **Properties**.

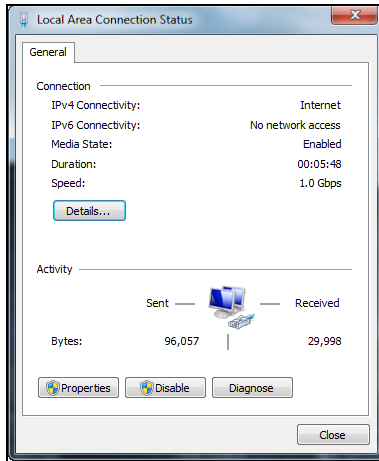

[1]

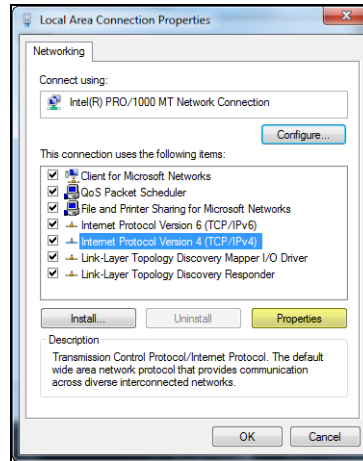

[2]

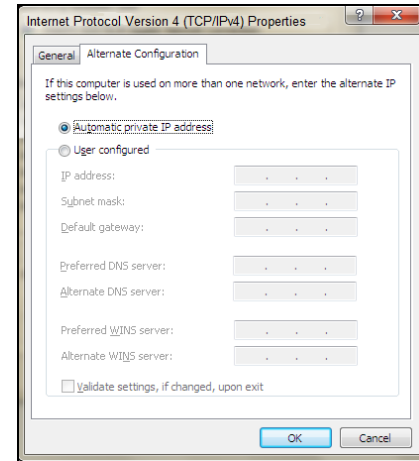

[3]

5. Please open now in window [3] the register **Alternate Configuration** and activate the checkbox **User configured**.

6. Now you can enter a user defined IP address for your PC. Please take care that the network part of the address has to be identical with the network part of the IP address of the TIM NetBox, thus **192.168.0**. For the host part you have to use an address which is different from the one of the TIM NetBox (100), so you may use **1** for example.

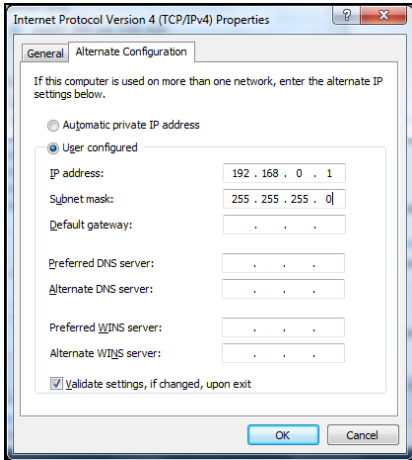

After you have made these settings and connected your PC with the TIM NetBox using an Ethernet cable your PC will establish a point-to-point connection. This procedure can take several minutes. In the **Network and Sharing Center** your network will now be shown up as a *non-identified network*.

Remote Access to the TIM NetBox (NetBox Utility)

For a remote access to the TIM NetBox install at first **NetBox Utility** on your PC. You will find the setup program (install.bat) in the folder **NetBox Utility** on your PIconnect CD. Beside the utility software also the UltraVNC viewer will be installed. You will find this program under **Start/ Programs/ NetBox-UltraVNC**. After the installation is finished you will find the following icon on your desktop:

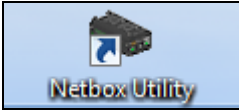

Now you can have access to a TIM NetBox which is directly connected to your PC or to a TIM NetBox which is located anywhere in the same network. Also remote connection via the internet is possible.¹⁾

1) For remote access from outside to a NetBox connected to a company network please ask your system administrator for possibly necessary settings.

Please start TIM NetBox Utility:

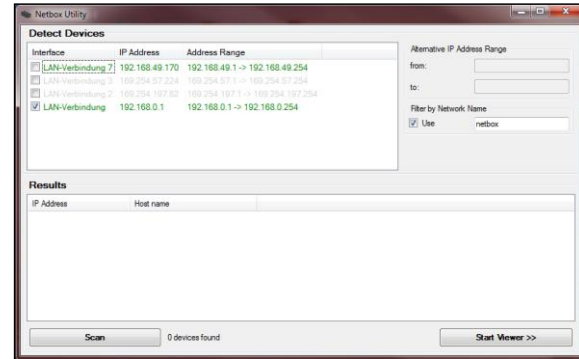

Select the desired network adapter and press **Scan**. The Utility program searches for TIM NetBoxes located in your network or directly connected to your PC. The filter function allows a selective search for TIM NetBoxes only. Mark the desired TIM NetBox in the window **Results** and press the button **Start Viewer >>**.

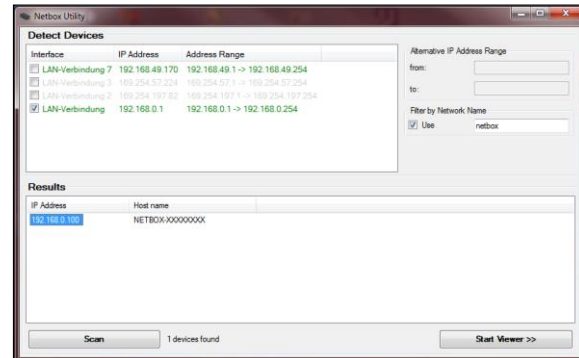

The UltraVNC viewer starts now and shows the desktop of the TIM NetBox:

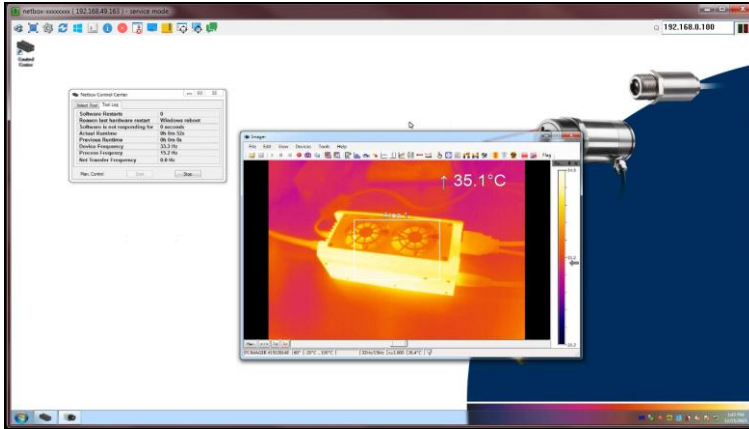

Alternatively you can scan only a certain IP address range:

Interface	IP Address	Address Range	Alternative IP Address Range
<input type="checkbox"/> LAN-Verbindung 7	192.168.49.170	192.168.49.1 -> 192.168.49.254	from: <input type="text" value="192.168.0.1"/>
<input type="checkbox"/> LAN-Verbindung 3	169.254.57.224	169.254.57.1 -> 169.254.57.254	to: <input type="text" value="192.168.0.100"/>
<input type="checkbox"/> LAN-Verbindung 2	169.254.197.82	169.254.197.1 -> 169.254.197.254	Filter by Network Name
<input checked="" type="checkbox"/> LAN-Verbindung	192.168.0.1	192.168.0.1 -> 192.168.0.100	<input checked="" type="checkbox"/> Use <input type="text" value="netbox"/>

Please mark the desired network connection up front.

File transfer between TIM NetBox and PC

To exchange files between the TIM NetBox and a directly connected or in the network located PC please move the cursor to the title bar of the **UltraVNC Viewer** window and press the right mouse button. Start **File Transfer**. Alternatively you can also press the following button in the tool bar:



In the following explorer window you see on the left side your local PC (LOCAL MACHINE) and on the right side the NetBox (REMOTE MACHINE). Now you can copy files between both computers via the network link by marking them and pressing **Send** or **Receive**.

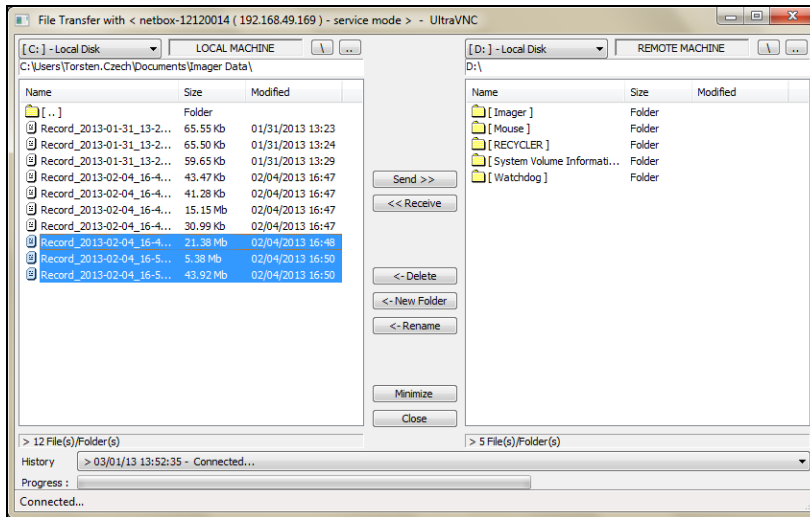

TIM NetBox Control Center

On the desktop of the TIM NetBox you will find a short cut for the TIM NetBox Control Center:



The Control Center allows an easy configuration of the TIM NetBox. On the tab **Select** you can select programs which will be started automatically after starting the TIM NetBox:

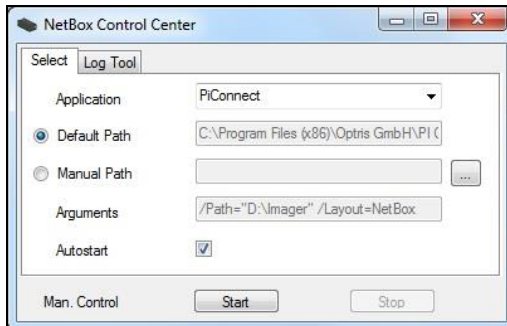

At **Application** you can select between TIMConnect, Imager Net Server and Custom Application.

Application **Operation mode of the TIM NetBox**

TIMConnect	Stand-Alone operation
Imager Net Server	Converter mode USB-Ethernet
Custom Application	Usage of the TIM NetBox for other applications (example: You can select here the pyrometer software CompactConnect which is already pre-installed on the TIM NetBox.)

As factory default setting the **TIMConnect** will be started by the Control Center.

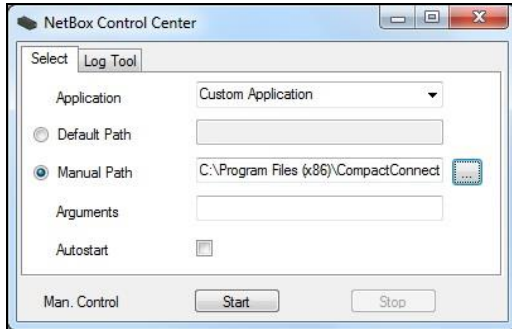

The start options selected in the Control Center are saved automatically in the TIM NetBox and are available after a restart.

At **Arguments** you can enter command line parameters (a special layout, with which the TIMConnect should start automatically e.g.). Activate **Autostart** in order to ensure that the selected application will be restarted automatically after a reboot of the NetBox.

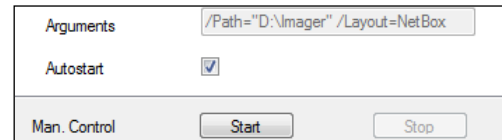

If, for any reason, the application is not working properly anymore (software crash), the NetBox Control Center will restart the software automatically (software watchdog) if autostart was selected.

The tab **Log Tool** is giving you the following information:

Software Restarts

Number of software restarts

Reason last hardware restart

Why the TIM NetBox was restarted the last time

Software is not responding for

Timer, which will be started at non-responding of the software and which is initiating the restart of the selected application

Actual runtime

Current runtime of the software

Previous runtime

Previous runtime of the software

Device Frequency

Camera frame rate

Process Frequency

Processed frame rate (display frame rate)

Net Transfer Frequency

Frame rate transferred via network (at Imager Net Server)

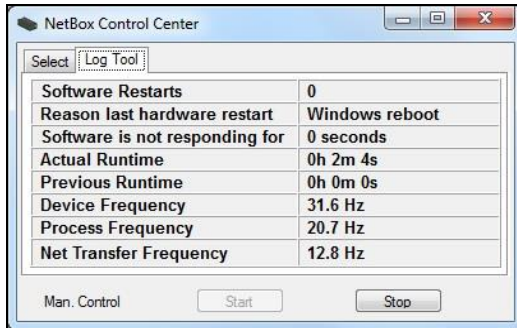

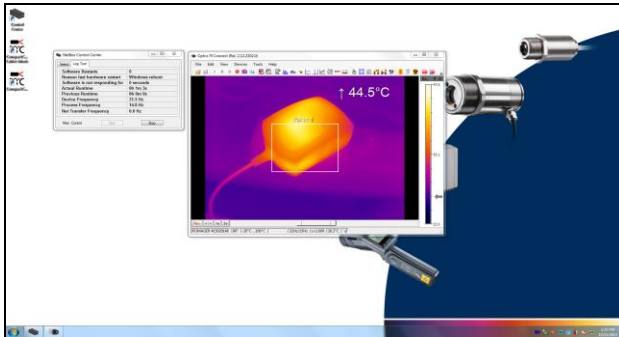

Screen of the TIM NetBox – TIM Connect

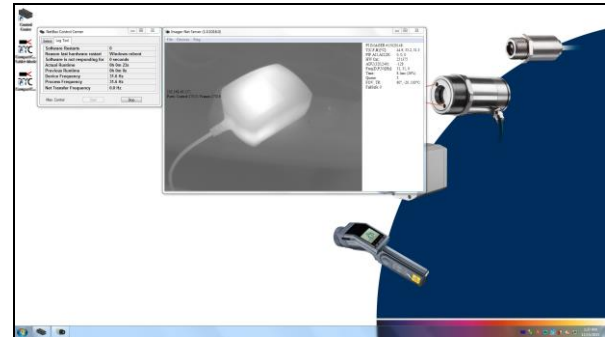

Screen of the TIM NetBox – Imager Net Server

Menu	File Devices Flag	exit of the program shows the connected imager manual operation of the camera flag
PI IMAGER #	[Serial number]	of the connected device
T (C, F, B)		Device temperatures (°C): C: FPA-Chip F: Flag temperature B: Housing temperature
PIF AI1, AI2, DI		Status of the PIF input: AI1: Analog IN1 (voltage level in mV) AI2: Analog IN2 (voltage level in mV) DI: Digital IN (Low/ High)
HW Cnt.		Hardware-Counter (frame counter)
ADU (192, 144)		ADU value of the center pixel (e.g. 192, 144 at PI4xx)
Freq (D, P, N)		Frequency (Hz): D: Device/ P: Processing/ N: Network
Time		Time per single frame
Queue		Number of frames in network queue
FOV, TR		Field of view (horizontal) of the imager lens, Temperature range
FailSafe		0/1 (alternating with connected industr. PIF) 1 at FailSafe alarm

Information in the *Imager Net Server* – application window

Converter mode USB – Ethernet

In this mode the TIM NetBox is used as converter from USB to Ethernet. Either a direct connection to a PC (point-to point) or a connection via an existing network is possible. On the TIM NetBox the program **Imager Net Server** must be active ¹⁾.

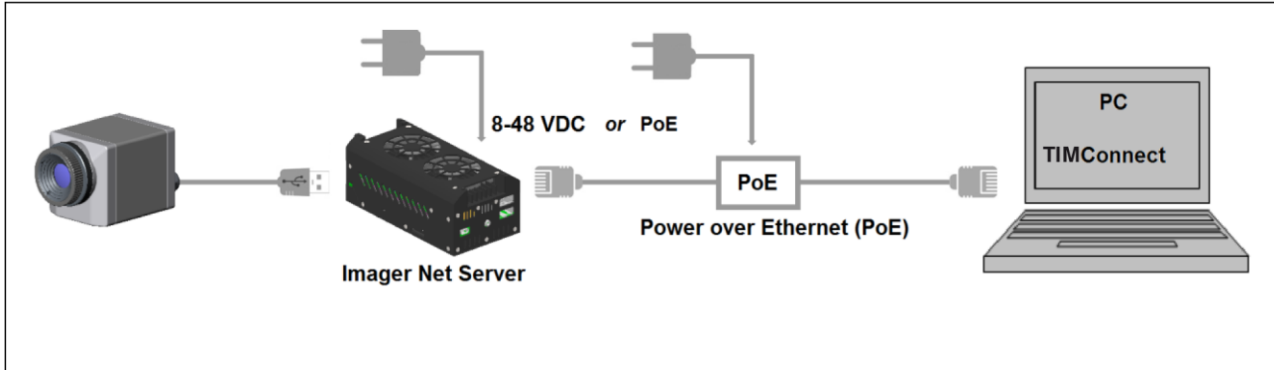

TIM NetBox as converter USB – Ethernet/ direct network connection

1) The models TIM450 G7 and TIM M-1 are not supported yet.

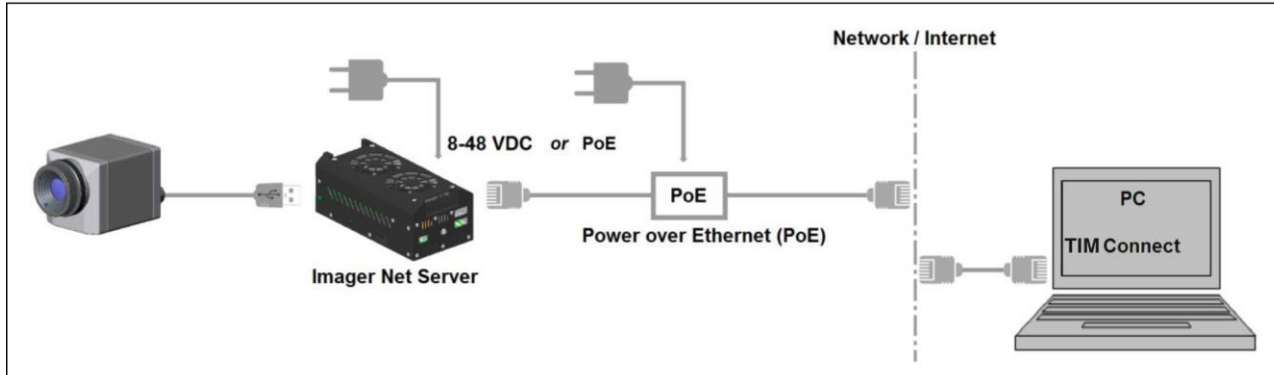

TIM NetBox as converter USB – Ethernet/ integration into a network

After establishing the network connection please start the TIMConnect on your PC and open the menu item **Tools/ Extended/ Remote devices...**

In the window which is appearing you should set a hook on **Enable** and enter the IP address of the TIM NetBox (**192.168.0.100 on a direct connection**) or the address range of your local network at **Detect devices**¹⁾. The fourth block should have the range **0 to 255**. If you now press **Ping** all computers inside the selected address range will be shown.

1) To determine the address range of your local network you can use NetBox Utility [► Remote Access to the NetBox].

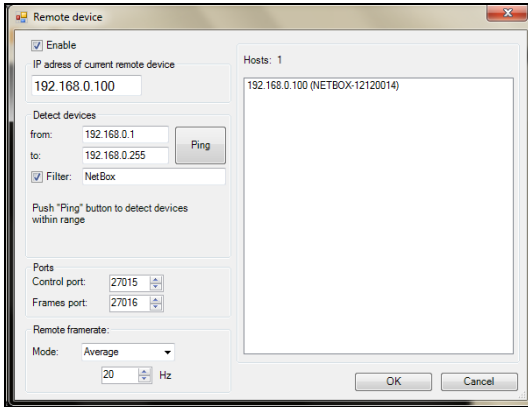

Search for network devices in TIMConnect

For a faster search in a network you should activate the **filter** and enter *NetBox*. Now only computers with *NetBox* in their name will be shown.

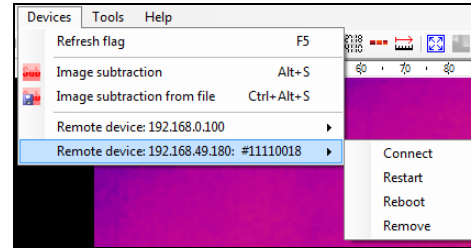

Device selection in TIMConnect

Under **Hosts** you can now select your TIMNetBox and press **OK**. The software will establish a connection to the remote device (imager) automatically.

Under **Remote framerate** you can enter the desired frame rate which should be transmitted via the network. Under the menu item **Devices** the imager which is connected to the TIM NetBox shows up now. The following functions can be selected here:

- Connect** **Manual connection with the remote device**
- Restart** **Restart of the Imager Net Server application on the TIM NetBox**
- Reboot** **Reboot of the NetBox**
- Remove** **Remove of the device entry in this menu**

If the used imager is connected for the first time to the TIM NetBox the following message appears:

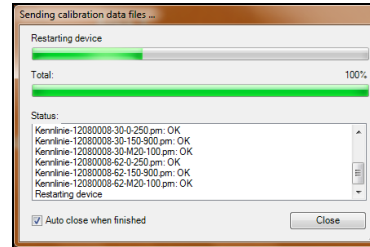
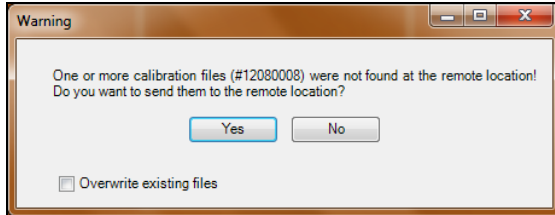

Please confirm with **Yes**. The calibration files will be transferred automatically from your PC to the TIM NetBox and stored there. Now you should see the live picture from the imager on your PC. Alternatively you can copy the calibration data also manually via a USB stick into the TIM NetBox folder **D:\Imager\Cali**.

Write Protection Filter

The TIM NetBox has a factory pre-installed write protection filter. This filter is protecting reliably the operating system and the complete drive C and allows a switch-off of the device without a shutdown of the operating system.

The write protection filter is shown as symbol in the task bar.

The colors have the following meaning:



red dot: protected mode



green dot: write mode

The TIM NetBox should be used only with an activated write protection filter [red dot].

To save changed settings or if you want to install additional software the write protection has to be deactivated temporarily. To do this please move the cursor to the red dot in the task bar and push the right mouse button:

- Save And Reboot
- Save and Shutdown
- Save And Standard Write Mode
- Restore by Reboot

You can select between four different actions:

Save and Reboot	Changes will be saved + Restart
Save and Shutdown	Changes will be saved + shut down
Save and Standard Write Mode	Changes will be saved + Switch into the write mode (green dot)
Restore by Reboot	Restart without saving of changes

If you select **Save and Standard Write Mode** the context menu will change to:



In order to go back to the protected mode select **Protected Mode**. All changes will be saved and the system will be restarted.

The SSD drive of the TIM NetBox has by factory default two partitions. The write protection refers to partition C only. On the partition D you can save application data. On drive D also the calibration data of the infrared imager are stored.

System Information

Watchdog

If, for any reason, the main software application (**TIMConnect** or **Imager Net Server**) does not work properly (software hang-up or crash) or if the main application will be closed, the integrated software watchdog (via the NetBox Control Center) is restarting the program automatically.

For this functionality it is required that the *Autostart* is activated in the **Select Tool**:

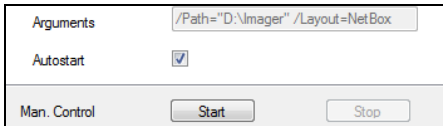

In addition a hardware watchdog is monitoring the Windows operating system permanently – you see the symbol [WD] in the right part of the task bar:



If the watchdog is recognizing a system error or problem it will restart the TIM NetBox automatically.

Startup

In the Windows Startup folder of the TIM NetBox the following shortcuts are set default:

NetboxControlCenter starts the program which was selected in the Select Tool
NetboxHardwareWatchdog starts the hardware watchdog application

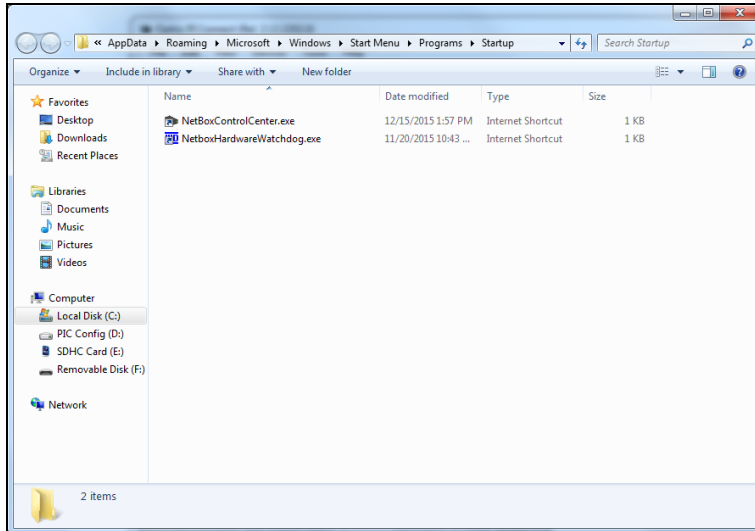

System Time

The TIM NetBox contains a CMOS battery which is used for keeping the system time if the computer is switched off. If a battery change should be necessary please open the battery compartment and exchange by a new battery of the same type (CR1225 or CR1632, depending on production date).

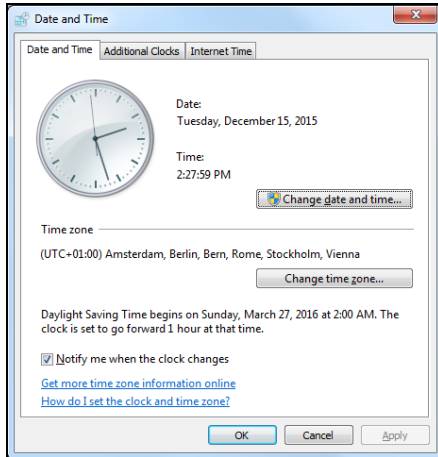

To adapt the TIM NetBox to your local time zone you have to open the Windows date and time setup (Control Panel/ Date and Time). The TIM NetBox is set by default to UTC+01:00. To save the new setting permanently you have to deactivate the ► **Write Protection Filter** temporarily.

System Recovery

In case a recovery of the Windows operating system of the TIM NetBox is necessary you should use the supplied USB recovery stick. Follow the steps described hereafter. **Do not disconnect power from the TIM NetBox during the recovery procedure.**

After the system recovery the TIM NetBox has the factory default settings. All data which was stored before on the SSD will get lost.

Step 1:

Connect a monitor and a USB keyboard with the TIM NetBox. Connect the USB Recovery stick to a free USB port of the TIM NetBox and switch on the unit.

Press and keep pressed the **DEL button** until the Aptio Setup Utility screen appears:

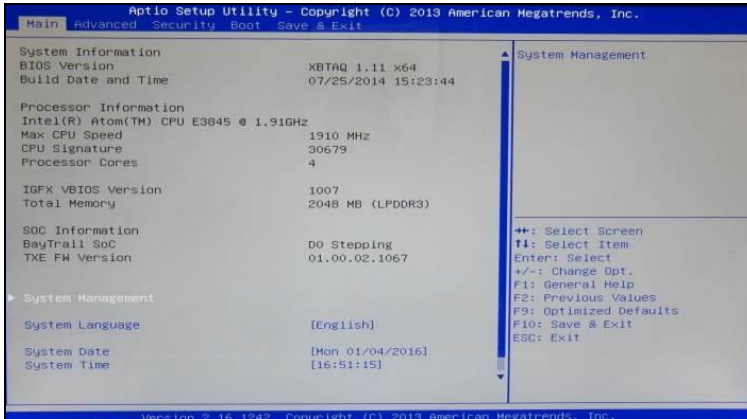

Step 2:

Select **Hard Drive BBS Priorities** in the menu **Boot** and press **Enter**:

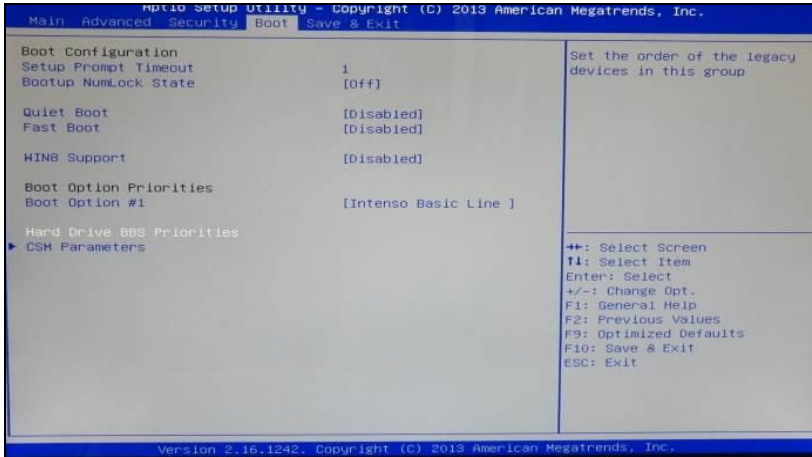

Step 3:

Select **Boot Option #1**, press **Enter** and select **Intenso Basic Line** (confirm with **Enter**):

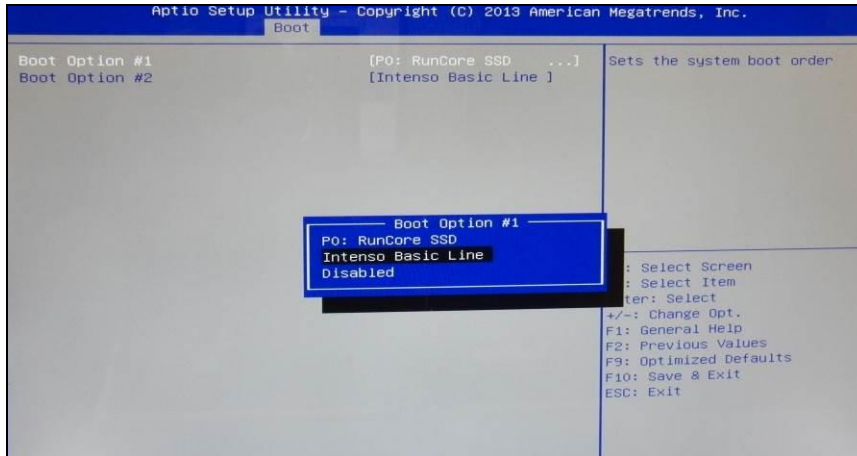

Step 4:

Now press **F10** and confirm with **Enter**:

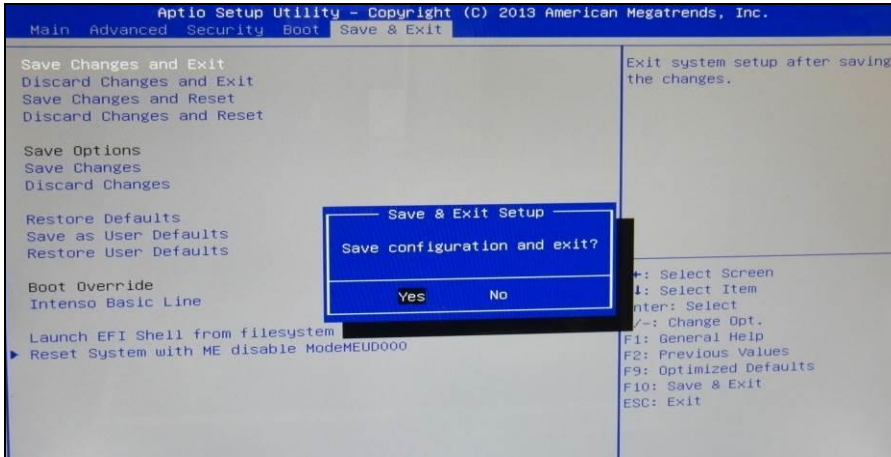

The system will restart now and boot from the USB stick.

Step 5:

Select **Recovery system** in the following screen and press **Enter**:

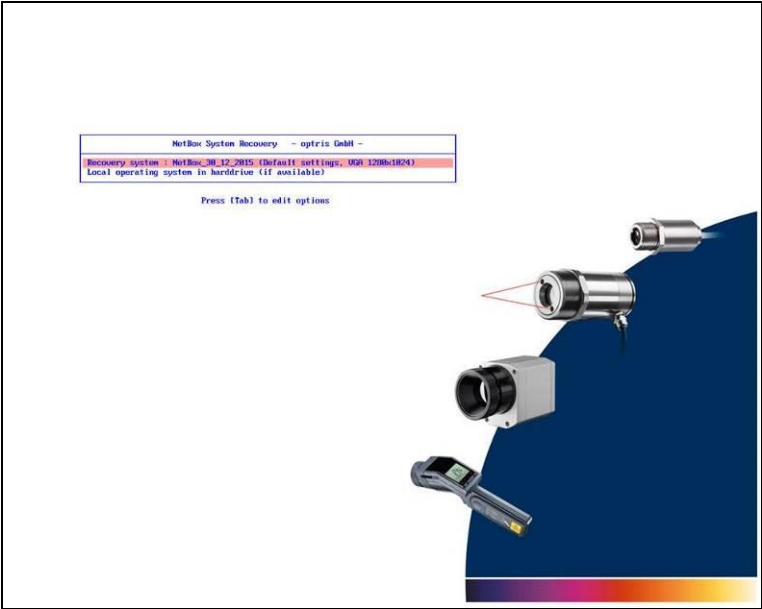

```
l 0.000181 pci 0000:00:14.2: PCI INT B -> GSI 12 (level, low) -> IRQ 19
l 0.000871 pci 0000:00:14.2: PCI INT B disabled
l 0.001971 Dispatching interrupts.
l 2.665400 Freeing initrd memory: 5256k freed
l 2.670293 smbios: initialising smbios tables (disabled)
l 2.678611 klogd-2000 mod(112801149.67111) installed
l 2.700503 hpsa:13 registered 4 I/O pass: lines: pre-allocated 0 pages
l 2.707273 UFS: Bk14 quota: Aqent_5.2.2
l 2.708700 hpsa:control-back table entries: 1024 (order 0, 40% bytes)
l 2.707590 sgmls has been set to 90
l 2.710000 aha: no lock for SSIsg (strg)
l 2.710271 Block layer SCSI generic (sg) driver version 0.4 loaded (major 2)
[3]
l 2.710000 In scheduler mode registered
l 2.710271 In scheduler deadline registered
l 2.710521 In scheduler CFQ registered (cfqfs113)
l 2.710611 pci_builtup: PCI Hot Plug PCI Core version: 0.5
l 2.710721 pci_hotplug: PCI Express Hot Plug Controller Driver version: 0.4
l 2.710741 acpi_hotplug: ACPI Hot Plug PCI Controller Driver version: 0.5
l 2.711542 usbfs: mode is 00000000, filelength=1048, page=0
l 2.711923 usbfs: scrolling: nohex
l 2.712344 usbfs: Transacted size=0x545, shift=0x1154
l 2.712923 usbfs: frachiffer at 0x1100000, mapped to 0xffff0000, using 18
75k, total=7075
l 2.720211 Gpiochip 0: attaching to output frame buffer device 100x20
l 2.720211 SMI: table is not found
l 2.720923 SMI: SMI is not enabled!
l 2.720923 SMI: SMI is not enabled!
l 2.720923 i2cchip: Warning for CPU core...
l 4.001121 i2cchip: No Ping & Pong device found
l 4.001413 Serial: 0000:00:00.0: ports 0 irq sharing enabled
l 4.001823 linux support: interface 00_103
l 4.002023 SMI: Ping to PC-C controller found, probing ports directly.
-
```

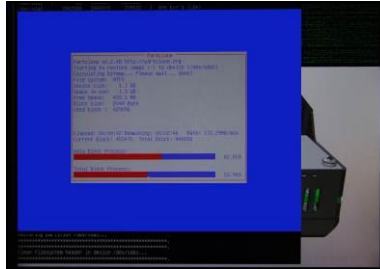

Screens during system recovery

After a complete recovery the TIM NetBox will restart and boot the system. After the booting process all necessary drivers will be installed automatically and a first configuration script will be started. Please follow the instructions:

```
taskeng.exe
Dieses Skript dient zur Konfiguration der Netbox U2!
Folgen Sie den Anweisungen.

An Ende der Prozedur koennen alle Schritte wiederholt werden falls eine Fehleing
abe erfolgt ist.

Zum Abbruch das Fenster schliessen oder [Strg] + [C] druecken

Press any key to continue . . . _
```



MICRO-EPSILON MESSTECHNIK GmbH & Co. KG
Königbacher Str. 15 · 94496 Ortenburg / Germany
Tel. +49 (0) 8542 / 168-0 · Fax +49 (0) 8542 / 168-90
info@micro-epsilon.de · www.micro-epsilon.com

X9751342-B021058HDR
© MICRO-EPSILON MESSTECHNIK

