



# More Precision

optoNCDT ILR // Laser-optical distance sensors





- Measuring range up to 500 m onto diffuse reflecting surfaces, up to 3000 m with reflector plate
- Distance and speed measurement
- Integral heating
- For very high measuring rates and high speed applications
- Easy installation and commissioning
- Accessories and special models available

optoNCDT ILR 1191 sensors are opto-electronic sensors for non-contact distance and speed measurement in industrial applications. The sensor is designed for very large measuring ranges, with and without reflector. Due to the very high measuring rate of the sensor, moving objects can be measured easily. The sensor operates according to the laser pulse time-of-flight principle and is therefore particularly well suited to applications with large distances. Commissioning of the sensor is straightforward due to a variety of interfaces and easy installation options. For outdoor use, the optoNCDT ILR 1191 is equipped with integral heating and protected to IP67.

#### Models with serial interface

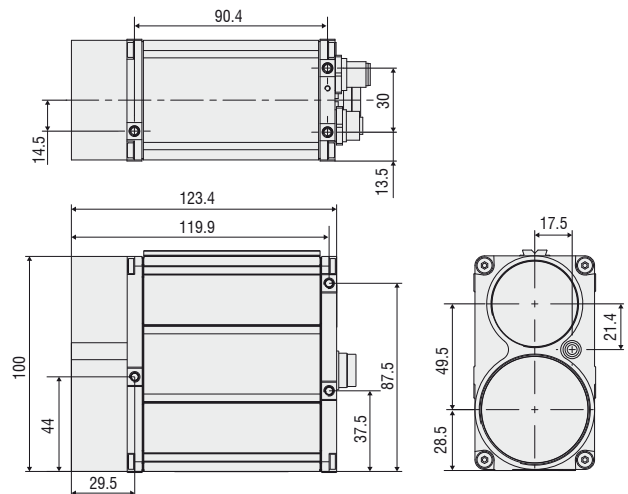

#### Models with SSI interfaces / Profibus

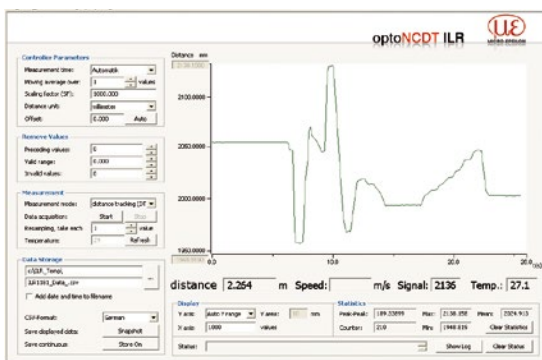
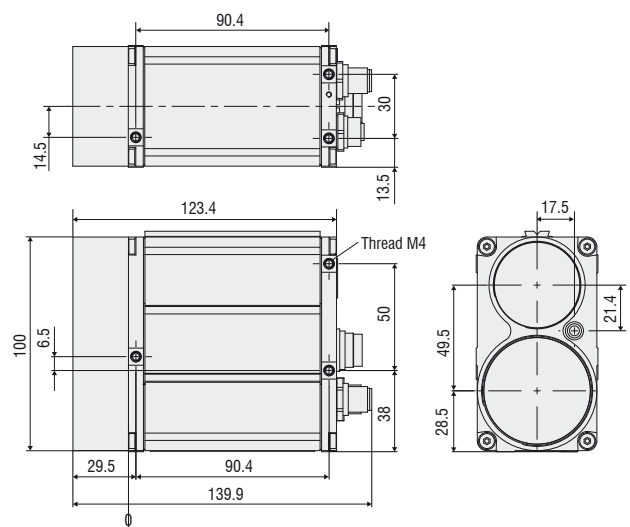

Configuration and measurement software for ILR1191

Model	<b>ILR1191-300</b>	
Article number	7112010	
Measuring range <sup>1)</sup>	black 6%	8 ... 150 m
	gray 10%	0.5 ... 200 m
	white 90%	0.5 ... 300 m
	Reflector film	0.5 ... 3000 m (ILR-RF250)
Speed	0 ms <sup>-1</sup> to 100 ms <sup>-1</sup>	
Repeatability	≤ 20 mm	
Resolution	1 mm	
Linearity <sup>2)</sup>	< ±20 mm (at measurement output 100 Hz); < ±60 mm (at measurement output 2 kHz)	
Measurement frequency	Distance measurement	2000 Hz
	Speed measurement	80 Hz
Light source	Measuring laser (infrared 905 nm) Sighting laser (red 635 nm)	
Laser safety class	EN 60825-1:2014	Measuring laser (laser class 1) Sighting laser (laser class 2)
Operating temperature	-40 ... +60 °C	
Storage temperature	-40 ... +70 °C	
Switching outputs	Q1 / Q2 (max 200 mA)	
Switching points	freely adjustable	
Switching hysteresis	freely adjustable	
Trigger input	adjustable trigger edge and delay, trigger pulse max. 30 V	
Serial interface	RS232 and RS422 with 1.2 kBaud ... 460.8 kBaud 24 bit, gray-coded, 50 kHz ... 1 MHz	
Profibus	RS485, 9.6 kBaud ... 12 MBaud	
Operating mode	single measurement, continuous measurement, external triggering, speed measurement	
Analog output	4 ... 20 mA (16 Bit DA)	
Temperature stability	≤ 50 ppm / °C	
Power supply	10 ... 30 VDC	
Max. power consumption	< 5 W without heating, 11.5 W with heating	
Connection	1 x 12-pin M16, 2 x 5-pin M12 B-coded	
Protection class	IP67	
Housing material	Aluminum strangeness profile, powder-coated	
Weight	800 g (depending on the equipment)	
Vibration/shock	500 g, 0.5 ms, 1 shock in each direction (DIN ISO 9022-30-08-1)	
	10 g, 6 ms, 1000 shocks in each direction (DIN ISO 9022-3-31-01-1)	
EMC	complies with 2014/30/EU	
Accessories	page 10	

<sup>1)</sup> Depending on target reflectance, ambient light influences and atmospheric conditions

<sup>2)</sup> Statistical spread of 95% over the entire measuring range

## Product identification

### ILR 1191 - 300 (0 x)

- Serial interface  
 1 = RS232  
 2 = RS422  
 4 = RS232 + Profibus

## Spot diameter ILR1191

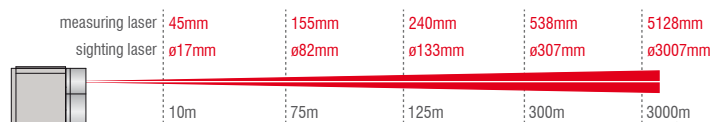

optoNCDT ILR 1191 use a semiconductor class 1 laser (operating mode) and a semiconductor class 2 laser (setup mode). Laser class 2 devices require no special safety precautions.

## Accessories

## Supply and output cable for ILR10xx series

Art. no.	Designation	
2901232	PC1000-2	Length 2 m
2901233	PC1000/90-2	Length 2 m, 90° connector
2901234	PC1000-5	Length 5 m
2901235	PC1000/90-5	Length 5 m, 90° connector
29011248	PC1000-10	Length 10 m
2901268	PC1000/90-10	Length 10 m, 90° connector

## Supply and output cable ILR11xx

Art. no.	Designation	
2901524	PC1100-3	Length 3 m
2901239	PC1100/90-3	Length 3 m, 90° connector
2901573	PC1100-5	Length 5 m
2901235	PC1100/90-5	Length 5 m, 90° connector
2901236	PC1100/10	Length 10 m
2901241	PC1100/90-10	Length 10 m, 90° connector
2901237	PC1100/20	Length 20 m
2901242	PC1100/90-20	Length 20 m, 90° connector
2901238	PC1100/30	Length 30 m
2901243	PC1100/90-30	Length 30 m, 90° connector
0323241	FC1100	Cable connector
0323242	FC1100/90	Cable connector, 90° (angled)
2901551	PC1100/90-3/RS232	Length 3 m, 90° connector, RS232

## Profibus

Art. no.	Designation	
2901435	PBC1100-I/O-5	Profibus input and output cable, 5 m
2901436	PBC1100-I-5	Profibus input cable, 5 m
2901437	PBC1100-I-10	Profibus input cable, 10 m
2901438	PBC1100-O-5	Profibus output cable, 5 m
2901439	PBC1100-O-10	Profibus output cable, 10 m
0323310	PBFC1100	Profibus socket
0323311	PBMC1100	Profibus plug
0323312	PBLR1100	Profibus terminating resistor

## Accessories for ILR10xx series

Art. no.	Designation	
7966001	ILR-RF250	Reflector film 250 x 250 mm
7966002	ILR-R250	Reflector 250 x 250 mm

## Accessories for ILR 118x / 1191 series

Art. no.	Designation	
7966014	ILR-MP1191	Mounting plate for ILR1191
7966052	ILR aligning aid for ILR1191	Aligning aid for ILR1191
7966016	ILR-PT1191	Protection tube, 100 mm for ILR1191
7966019	ILR-RF118x	Reflector film 250 x 250 mm for ILR118x
7966020	ILR-MT118x	Mounting clamp for ILR118x
7966025	ILR-MP118x	Mounting plate for ILR118x
7966021	ILR-MTN118x	Slot nuts for ILR118x
7966022	ILR-FBV118x	Air purge collar for ILR118x
7966023	ILR-PG118x	Protective glass for ILR118x
7966024	ILR-FV118x	Filter adapter for ILR118x
2213025	IF2001/USB	RS422/USB converter

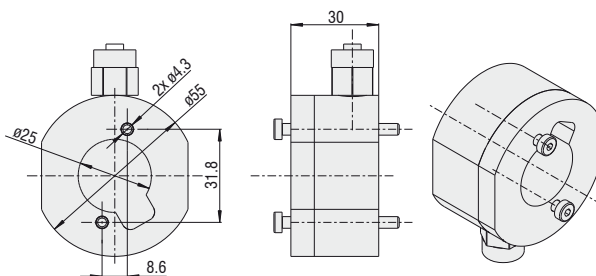

ILR-FBV118x air purge collar for ILR118x

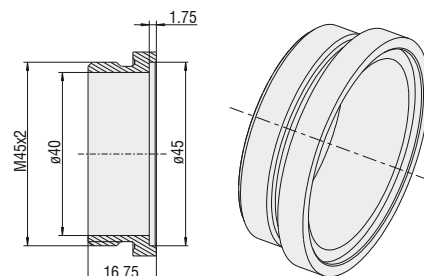

ILR-PG118x protection glass for ILR118x

**Free setup and configuration software**

The scope of supply includes software for easy sensor configuration. The settings can be implemented conveniently via a Windows user interface on the PC. The sensor parameters are transmitted to the sensor via the serial port and can also be saved if required. The software also contains a module which can display and store the measurement results. The sensor is connected to the PC via the sensor cable using a USB converter.

**Free download**

Download free of charge from [www.micro-epsilon.com/download](http://www.micro-epsilon.com/download): software and driver for easy sensor integration in existing software.

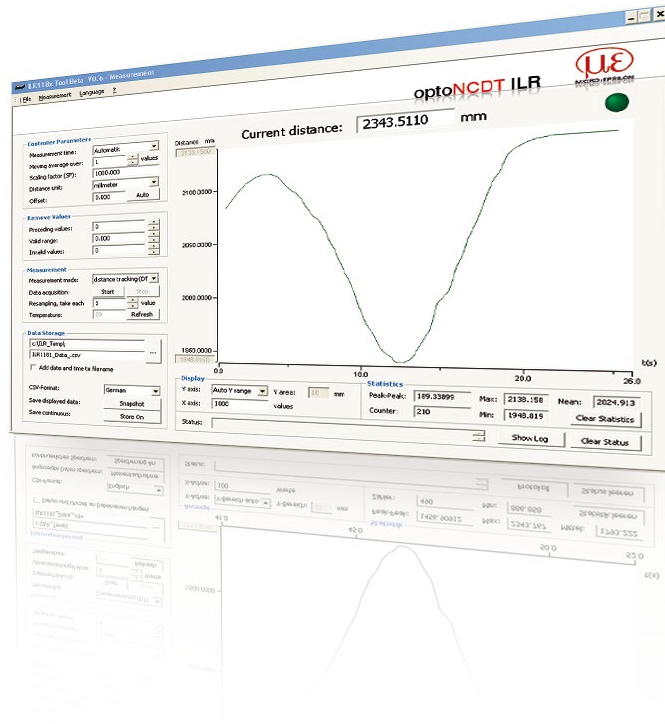

**Applications**



**Position measurement on gantry cranes**

Gantry cranes require multiple measurement tasks: Positioning of the trolley, detection and dimensioning of containers and monitoring of the minimum clearance between the cranes. The ILR1191 with a very large measuring range and low response time is designed for these measurement tasks.

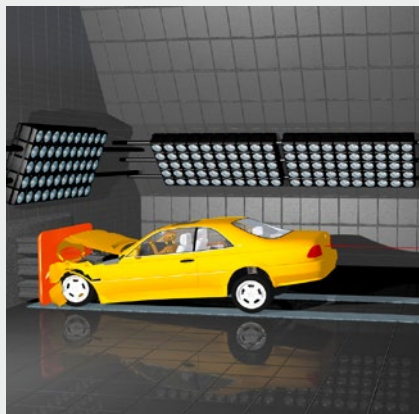

**Crash test speed measurement**

At acceleration of cars during crash tests, an ILR1191 measures the impact speed and deformation of the test vehicle.

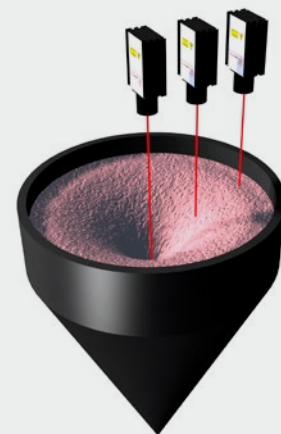

**Filling level measurement in silos**

Depending on the required accuracy, laser distance sensors determine the filling level of silos at up to four points. Based on these distances, the filling level is calculated.

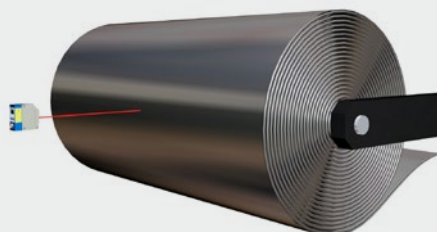

**Acquisition of coil diameters**

The quantity of steel wound on and off is monitored via the acquisition of coil diameters using laser probes.

## Sensors and Systems from Micro-Epsilon



Sensors and systems for displacement, distance and position



Sensors and measurement devices for non-contact temperature measurement



Measuring and inspection systems for metal strips, plastics and rubber



Optical micrometers and fiber optics, measuring and test amplifiers



Color recognition sensors, LED analyzers and inline color spectrometers

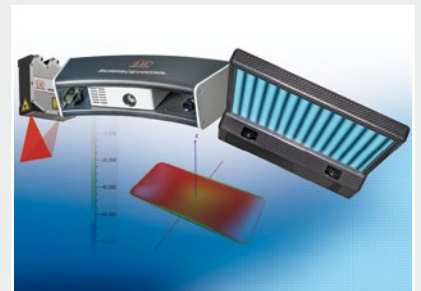

3D measurement technology for dimensional testing and surface inspection