

White Light Source Digital Fiber Amplifier

# D3WF Series

- D3WF-TP      D3WF-TMCP4
- D3WF-TN      D3WF-TMCN4
- D3WF-TSCP4
- D3WF-TSCN4

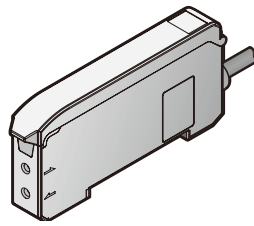

OPTEX FA CO., LTD.

- Thank you for purchasing this White Light Source Digital Fiber Amplifier D3WF.
- Before using this product, please read this manual carefully to ensure proper use.
- Read this manual thoroughly, and then keep this manual at hand so that it can be used whenever necessary.
- The warranty period of this product is one year after delivery. However, any fault attributable to natural disasters or any other similar disasters or modification or repair will be excluded from the scope of the warranty.

## Safety Precautions

Safety precautions for ensuring safe operation of this product are displayed as follows with the following symbols. Precautions listed here describe important information about safety. Make sure to follow them accordingly.

### Safety Symbols

	<b>WARNING</b> Indicates that any improper operation or handling may result in moderate or minor injury, and in rare cases, serious injury or death. Also indicates a risk of serious property damage.
	<b>CAUTION</b> Indicates that any improper operation or handling may result in minor injury or property damage.

	<b>WARNING</b>
	Do not disassemble, repair, modify, deform under pressure, or attempt to incinerate this product. Doing so may cause injury or fire.
	This product is not explosion-proof and should not be used around flammable or explosive gases or liquids. Doing so may cause ignition resulting in an explosion or fire.
	Do not use air dusters or any spray that uses flammable gas around the product or on the inside of the product. Doing so may cause ignition resulting in an explosion or fire.
	Do not install this product in any of the following locations. Doing so may cause a fire, damage, or a malfunction. <ol style="list-style-type: none"> <li>Locations where dust, salt, iron powders, or vapor (steam) is present.</li> <li>Locations subjected to corrosive gases or flammable gases.</li> <li>Locations where oil or chemical splashes may occur.</li> <li>Locations where heavy vibrations or impacts may occur.</li> <li>Locations where the ambient temperature exceeds the rated range.</li> <li>Locations subject to rapid temperature changes (or where condensation occurs).</li> <li>Locations with strong electric or magnetic fields.</li> <li>Outdoor locations or locations subject to direct light.</li> </ol>
	This is a class A product. In a domestic environment this product may cause radio interference, in which case the user may be required to take adequate measures.
	This product is not intended for use with nuclear power, railways, aviation, vehicles, medical equipment, food-handling equipment, or any application where particular safety measures are required. Absolutely do not use this product for any of these fields.
	This product cannot be used in applications that directly or indirectly detect human bodies for the purpose of ensuring safety. Do not use this product as a detection device for protecting the human body.
	What to do in the event of a malfunction such as smoke being emitted from the product if you detect any malfunction including emission of smoke, abnormal smells or sounds, or the body becoming very hot, immediately stop operating the product and turn off the sensor power. Failure to do so may cause a fire. Repairing the product is dangerous and should in no way be performed by the customer. Contact an Optex FA sales representative for repairs.

### CAUTION

- Make sure to turn the power off before wiring the cable or connecting/disconnecting the connector. Connecting or disconnecting while energized may damage the product or cause electric shock.
- Avoid using the transient state while the power is on (300 ms). Output could become unstable, causing unexpected operation.
- Do not wire with high voltage cables or power lines. Doing so may cause malfunction or damage by induction.
- Do not bend the cable when below the freezing point. This may cause the cable to break.
- Do not drop the product or subject the product to strong impacts. Doing so may damage the product.
- Follow the instructions in this manual or the specified instruction manual when wiring the product or the dedicated controller for the correct wiring method. Incorrect wiring can damage the product or the controller, or cause a malfunction.
- When disconnecting the connector, be careful not to touch the terminals inside the connector, and do not allow foreign objects to enter the connector.
- Install this product as far away as possible from high-voltage equipment, power equipment, equipment that generates large switching surges, inverter motors, welders, or any equipment that can be a source of noise.
- When connecting or disconnecting the cable, make sure to hold it by the connector portion, and do not apply excessive force to the cable.

### NOTICE

- After carefully considering the intended use, required specifications, and usage conditions, install and use the product within the specified ranges.
- All specifications may be changed without notice.
- When using this product, it is the responsibility of the customer to ensure necessary safety designs in hardware, software, and systems in order to prevent any threat to life, physical health, and property due to product malfunction or failure.
- Do not use this product for the development of weapons of mass destruction, for military use, or for any other military application. Moreover, if this product is to be exported, comply with all applicable export laws and regulations, including the "Foreign Exchange and Foreign Trade Act" and the "Export Administration Regulations," and carry out the necessary procedures pursuant to the provisions therein.
- For more details on conformity to the Restriction of Hazardous Substances Directive for this product, please contact an Optex FA sales representative. Before using this product, fully examine the applicable environmental laws and regulations, and operate the product in conformity to such laws and regulations. Optex FA does not assume any responsibility for damages or losses occurring as a result of noncompliance with applicable laws and regulations.
- Detection characteristics and digital display values may vary depending on the state of the target object and variations among individual products.

## 1. Included Accessories

- This instruction manual
- Mounting bracket

## 2. Dimensions

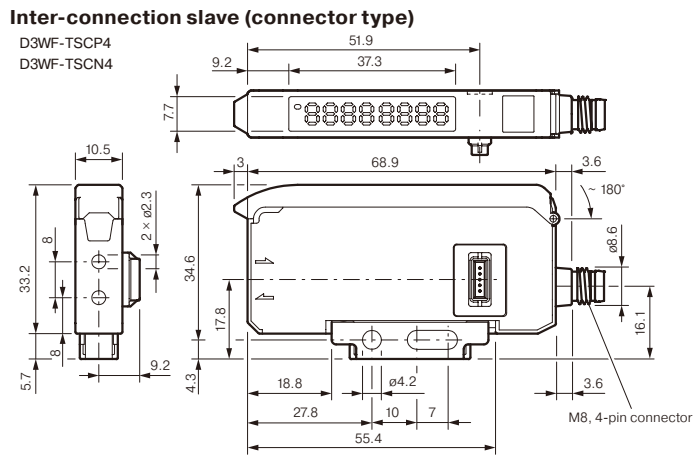
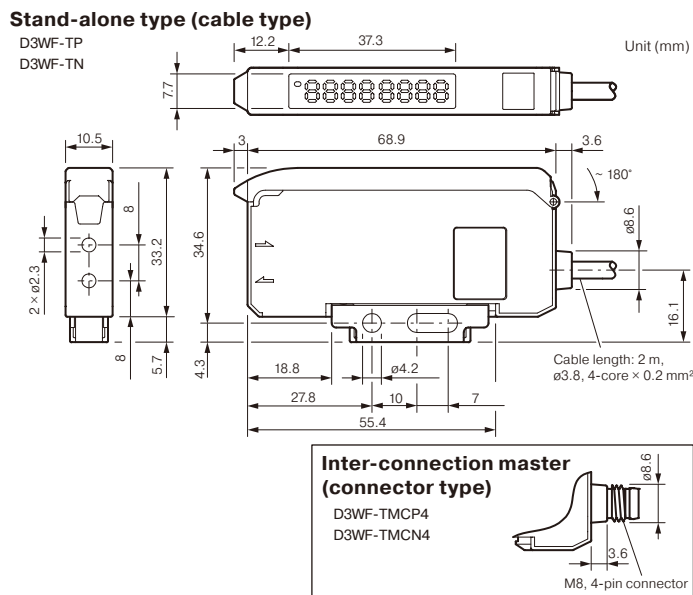

## 3. I/O Circuit Diagram

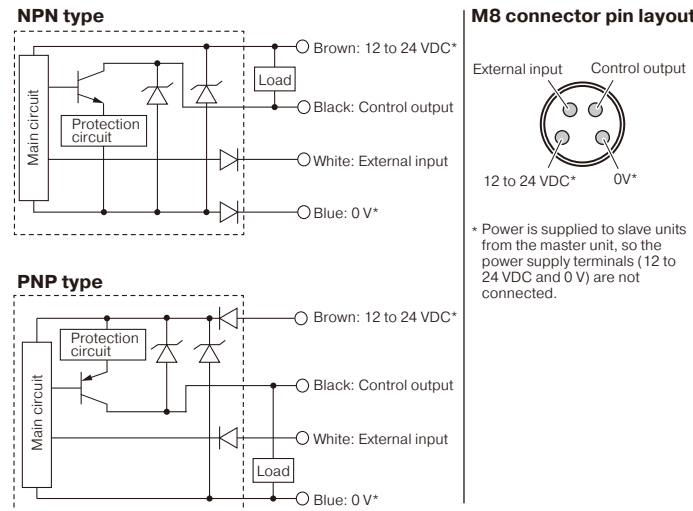

## 4. Mounting

### Mounting the amplifier

Hook the fiber unit connector side tab to the DIN-rail (①), and press down until the hook locks (②).

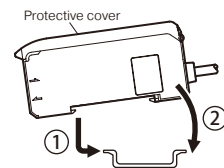

### Removing the amplifier

While pressing the amplifier body in the direction of ①, lift the fiber unit connector side to remove (②).

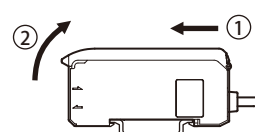

### Mounting the fiber unit

Tilt the fiber lock lever (①), and insert the fiber through the insertion opening until it stops (②). Return the fiber lock lever to the stop position (③).

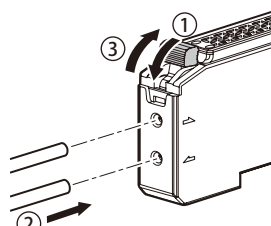

### CAUTION

When using a coaxial reflective type fiber, install single-core fiber or fiber containing white line on the emitting side, and multi-core fiber on the receiving side.

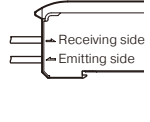

### How to use the small diameter adapter

1. With the adapter cap turned all the way to the left, insert the fiber the necessary length and turn the adapter cap to the right to lock it.
2. Cut the unnecessary parts of the fiber with fiber cutters.

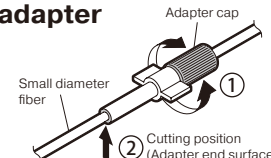

### Installing additional amplifier units

1. Mount each amplifier unit on the DIN-rail.
2. Slide the slave unit and connect it to the inter-connection connector.
3. Use the end plates to secure the amplifier units from both sides.

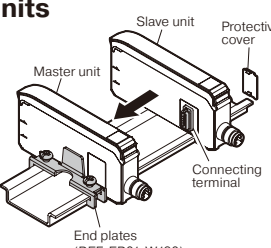

### CAUTION

- Be sure to turn off the power before performing this work.
- When installing additional amplifier units, be sure to use a DIN-rail and end plates.
- After installing additional amplifier units, check the ambient temperature.
- To prevent connecting terminals from being short-circuited, be sure to attach protective covers to connecting terminals that are not in use.
- Do not remove inter-connected amplifiers from the DIN-rail.

## 5. Part Names

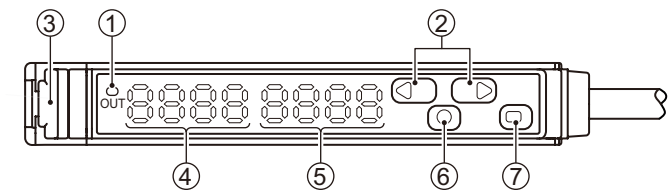

No.	Name	Details
①	Output indicator (orange)	Illuminates in orange when output is ON.
②	Selection buttons (+/- buttons)	Finely adjust the sensitivity. Select items when setting.
③	Lock lever	Raise the lever to secure the inserted fiber.
④	Main display (red)	Shows the current receiving light level on a 7-segment display.
⑤	Sub display (green)	Shows the current threshold on a 7-segment display.
⑥	Mode button	Used when configuring settings.
⑦	Teaching button	Used when performing teaching.

## 6. Teaching (Sensitivity Setting)

Configure the mark detection settings (perform teaching). There are three types of teaching (dynamic teaching, 2-point teaching, and 1-point teaching). Select the mode that matches the application.

### Teaching without stopping the line

Pass a non-marked part of the workpiece followed by a marked part of the workpiece by the sensor to perform teaching.

#### Dynamic teaching

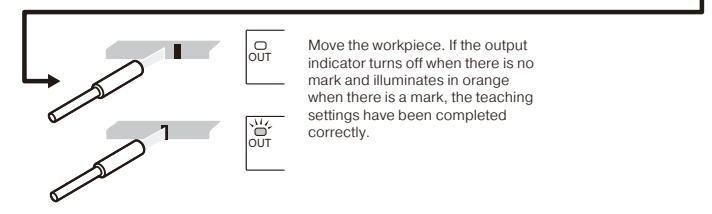
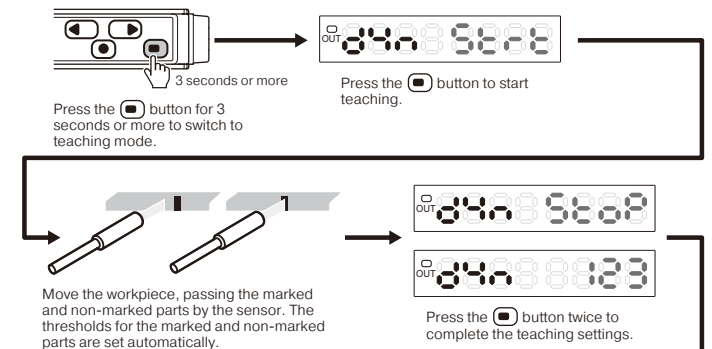

### Teaching with marked and non-marked parts

Perform teaching when a mark is present and when no mark is present. The threshold value is set and stored between the first and second points. Perform teaching with the marked part for the first point and with the non-marked part for the second point.

#### 2-point teaching

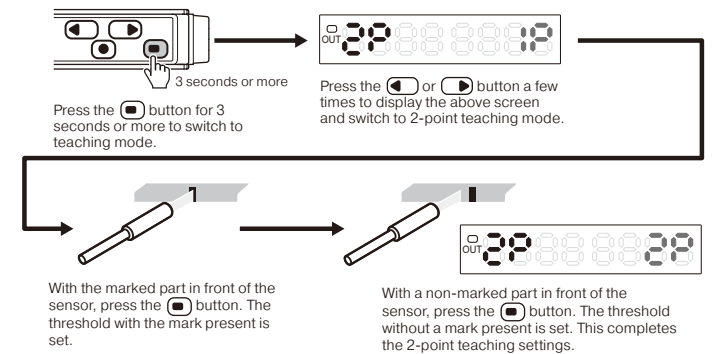

### Teaching just with the marked part

Ideal for detecting only within a fixed range of received light. The threshold is set in the range of the receiving light level  $\pm$  approximately 10% (default value). Perform teaching with the marked part detected.

#### 1-point teaching

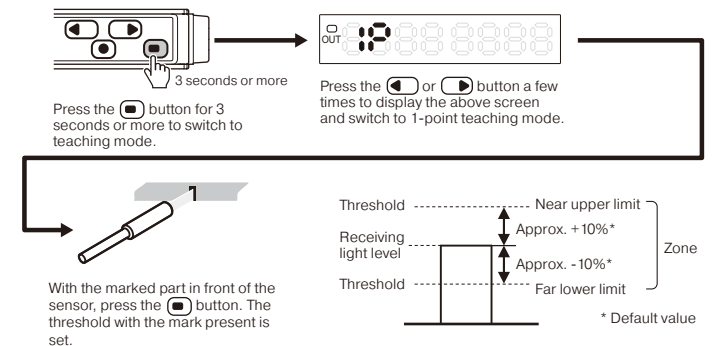

The threshold can be selected from  $\pm 10\%$ ,  $\pm 20\%$ , and  $\pm 50\%$  of the receiving light level. For details on how to configure the settings, see "Setup mode, 1-point teaching zone setting" under [7 Menu List] on the back of this document.

# 7. Menu List

The following three types of display screens are available.

Operation mode	Setup mode	Teaching mode
This display is used when performing actual detections. It is displayed when the power turns on. Example:  Receiving light level Threshold	This display is used when configuring settings. Press the mode button for 3 seconds or more to switch to this display. Example:  Name of the function to set Set value of the function	This display is used when performing teaching. Press the teaching button for 3 seconds or more to switch to this display. Example:  Name of the teaching type to set

## Setup mode

Press the button for 3 seconds or more in the operation mode

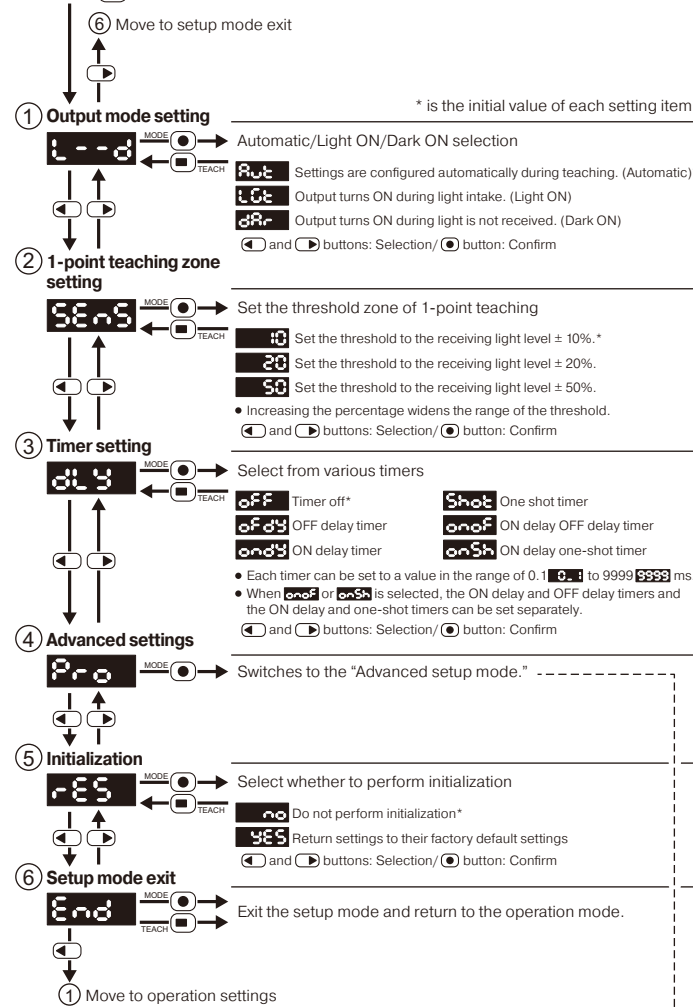

## Advanced setup mode

Normally, the amplifier can be used just with setup mode, but configure the settings in advanced setup mode if necessary.

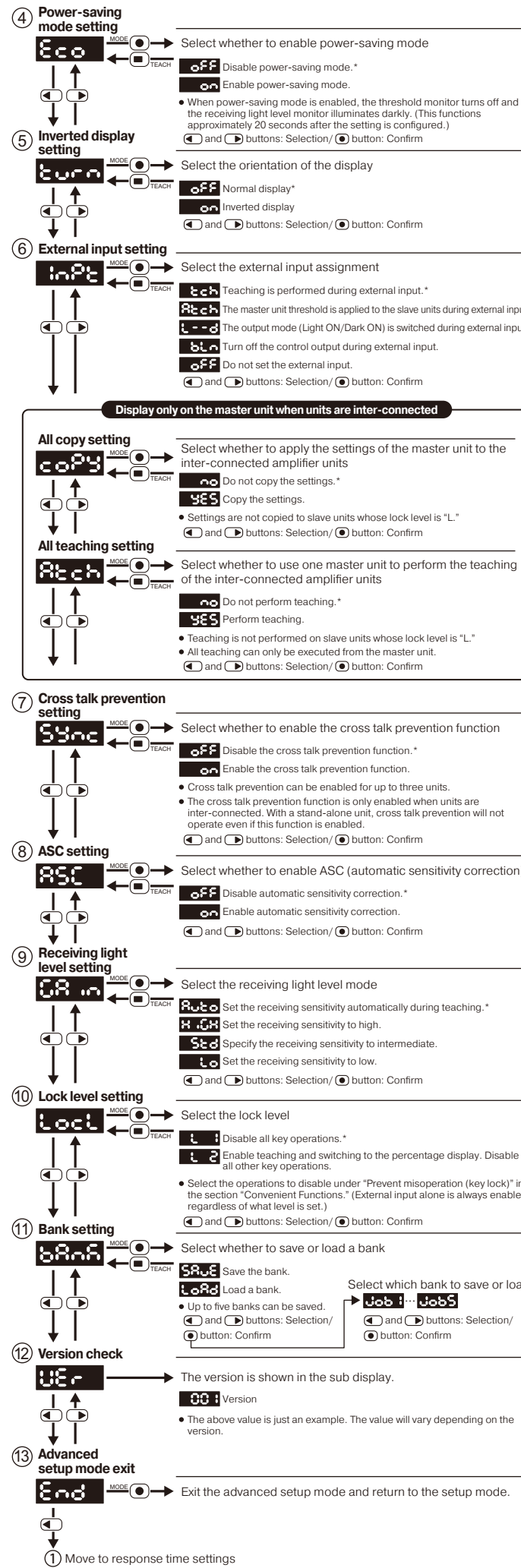
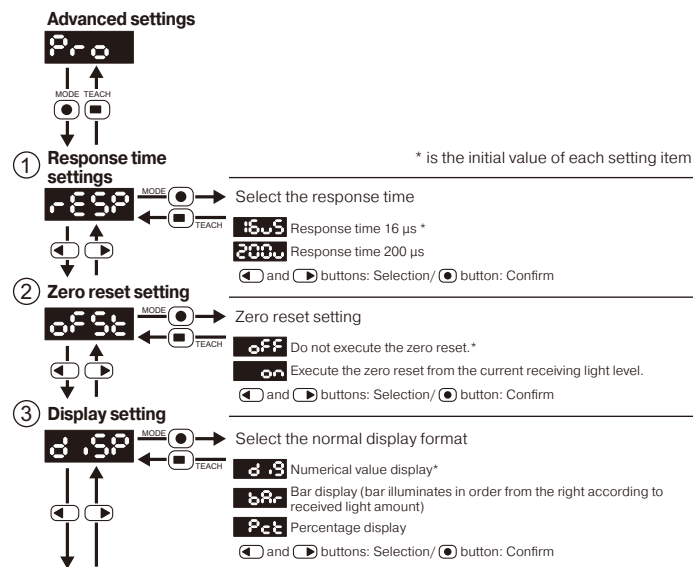

## Teaching mode

Press the button for 3 seconds or more in the operation mode

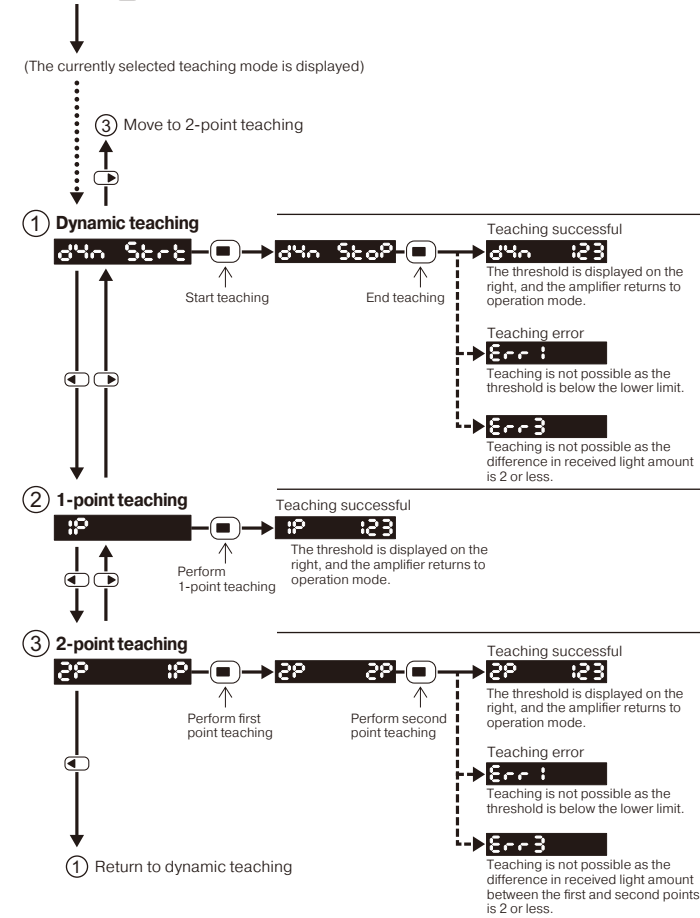

# 8. Convenient Functions

## Initialize settings

All settings are returned to their factory default settings.

- Press the button for 3 sec. or more to enter setup mode.
- Press the button multiple times to display , and then confirm with the .
- Display with the , and perform initialization with the .

\* "Output setting" is not changed even if initialization is performed.

## Prevent misoperation (key lock)

Disable key operation to prevent misoperation, etc.

While in operation mode, press the simultaneously for 3 seconds or more. Key lock is canceled by performing the same operation.

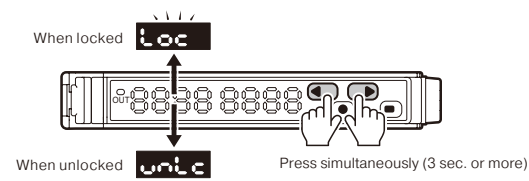

## Display received light amount percentage

Sets the display as a percentage.

- Press the button for 3 sec. or more to enter setup mode.
- Press the button multiple times to display , and then confirm with the .
- Press the button multiple times to display , and confirm with the .
- Display with the , and set the percentage display with the .

## Threshold adjusting mode setting

- In operation mode, press the and buttons to adjust the threshold, and then confirm with the .
- Returns to operation mode after confirming.

Threshold setting range 4 to 9999 (using digital display) \* Returns to operation mode if there is no operation for 5 seconds

# 9. Specifications

Type	Stand-alone type	Inter-connection master	Inter-connection slave
Model	D3WF-TN D3WF-TP	D3WF-TMCN4 D3WF-TMCP4	D3WF-TSCN4 D3WF-TSCP4
Light source	White LED		
Response time	High: 16 μs*, Standard: 200 μs		
Sensitivity adjustment	Various types of teaching and manual adjustment		
Indicators	Output indicator (orange)		
Digital display	7-segment, 8-digit display (red: 4-digit, green: 4-digit)		
Control output	NPN/PNP open collector max. 100 mA*2/ 30 VDC, residual voltage: 1.8 V or less		
External input	Teaching input, *3 all teaching input, output mode selection, control output OFF, input OFF		
Cross talk prevention	—	Can be enabled for up to three units depending on the settings	
Timer function	ON delay, OFF delay, one-shot, ON + OFF delay, ON + one-shot settable to 0.1 to 9999 ms		
Output mode	Light ON/Dark ON, set automatically during teaching, switched with external input and the settings		
No. of connectable units	—	Max. 16 (including master unit)	
Connection type	Cable type: 2m length	Connector type: M8, 4-pin	
Insulation resistance	20 MΩ or more (with 500 VDC)		
Rating	Supply voltage	12 to 24 VDC ± 10%, including 10% ripple (p-p)	
	Power consumption (normally)	864 mW (36 mA or less at 24 V)	
	Power consumption (Eco mode)	720 mW (30 mA or less at 24 V)	
Warm-up time	300 ms		
Applicable regulations	EMC	EMC directive (2014/30/EU)	
	Environment	RoHS directive (2011/65/EU), China RoHS (MIIT Order No. 32)	
Applicable standards	EN 60947-5-2		
Company standards	Noise resistance: Feilen Level 3 cleared		
Photobiological safety	Risk group 2 (IEC 62471/JIS C 7550)		
Environmental resistance	Ambient temperature/humidity	-25 to +55°C*/35 to 85%RH (no freezing or condensation)	
	Ambient illuminance	Sunlight: 10000 lx or less, Incandescent light: 3000 lx or less	
	Vibration resistance	10 to 55 Hz: double amplitude 1.5 mm; 2 hours in each of the X, Y, and Z directions	
	Shock resistance	Approx. 50 G (500 m/s <sup>2</sup> ), 3 times in each of the X, Y, and Z directions	
	Protection circuit	Reverse connection protection, overcurrent protection	
	Degree of protection	IP50	
Material	Housing, cover: PC		
Weight	Approx. 71 g (including cable)	Approx. 25 g	
Included accessories	Mounting bracket		

- \*1: The response time is 32 μs when inter-connection type units are inter-connected and the cross talk prevention function is on.  
 \*2: When used as a stand-alone unit or when the number of inter-connected units including the master unit is 2 or 3. Use a load current of 50 mA or less for 4 to 8 units and 20 mA or less for 9 to 16 units.  
 \*3: Teaching mode from external input is a mode executed in advance by the main unit (default: dynamic teaching).  
 \*4: When used as a stand-alone unit or when the number of inter-connected units including the master unit is 2 or 3. Keep at -25 to +50°C for 4 to 8 units and -25 to +45°C for 9 to 16 units.

## Model naming rules

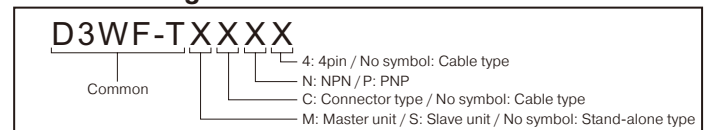

## Eye safety

This product is included in the scope of "IEC 62471/JIS C 7550: Photobiological safety of lamps and lamp systems," a standard issued by the International Electrotechnical Commission (IEC). This product corresponds to "risk group 2," which is explained below.

"Risk group 2" indicates moderate risk to organisms. Lamps in this group do not pose a hazard because organisms are protected by way of blinking and other such aversion responses to very bright light sources or by way of thermal discomfort. However, the light may become very intense if it is condensed or under similar usage conditions, which may have an adverse effect on the eyes, so do not look directly at the light source.

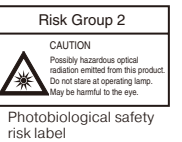

- Support for the China RoHS directive
- For details on the support for the China RoHS (the Administrative Measure on the Control of Pollution Caused by Electronic Information Products), see the following website.  
[https://www.optex-fa.com/rohs\\_cn/](https://www.optex-fa.com/rohs_cn/)

# OPTEX FA CO.,LTD.

[Headquarters]  
 91 Chudoji-Awata-cho Shimogyo-ku Kyoto 600-8815 JAPAN  
 TEL +81-75-325-1314 FAX +81-75-325-2936

<https://www.optex-fa.com>